

Mr. H. GRAYSON

ELECTRICAL COMMUNICATION

*Technical Journal of the
International Telephone and Telegraph Corporation
and Associate Companies*

INVENTOR OF THE CATHODE-RAY TUBE

THE STORY OF COPPERWELD

TRENDS IN MILITARY ELECTRONIC-EQUIPMENT DESIGN

SINGLE-RECEIVER AUTOMATIC DIRECTION FINDER

SHORT-RANGE POSITION FINDING

DESIGN OF AN IONIZATION MANOMETER TUBE

LONG-DISTANCE TELEPHONE COMMUNICATION CIRCUITS

EVALUATION OF TRANSMISSION EFFICIENCY

IN MEMORIAM—J. E. KINGSBURY

DECEMBER, 1948

Volume 25

Number 4



ELECTRICAL COMMUNICATION

Technical Journal of the
INTERNATIONAL TELEPHONE AND TELEGRAPH CORPORATION
and Associate Companies

H. P. WESTMAN, Editor

F. J. MANN, Managing Editor

J. E. SCHLAIKJER, Editorial Assistant

H. T. KOHLHAAS, Consulting Editor

REGIONAL EDITORS

- E. G. PORTS, Federal Telephone and Radio Corporation, Newark, New Jersey
- B. C. HOLDING, Standard Telephones and Cables, Limited, London, England
- P. F. BOURGET, Laboratoire Central de Télécommunications, Paris, France
- H. B. WOOD, Standard Telephones and Cables Pty. Limited, Sydney, Australia

EDITORIAL BOARD

- | | | | | | |
|-------------------|---------------|--------------|------------------|---------------|----------------|
| H. Busignies | H. H. Buttner | G. Deakin | E. M. Deloraine | W. T. Gibson | Sir Frank Gill |
| W. Hatton | E. Labin | E. S. McLarn | A. W. Montgomery | Haraden Pratt | G. Rabuteau |
| F. X. Rettenmeyer | T. R. Scott | C. E. Strong | A. E. Thompson | E. N. Wendell | W. K. Weston |

Published Quarterly by the

INTERNATIONAL TELEPHONE AND TELEGRAPH CORPORATION

67 BROAD STREET, NEW YORK 4, N.Y., U.S.A.

Sosthenes Behn, Chairman

William H. Harrison, President

Charles D. Hilles, Jr., Vice President and Secretary

Subscription, \$2.00 per year; single copies, 50 cents

Electrical Communication is indexed in Industrial Arts Index

Copyrighted 1948 by International Telephone and Telegraph Corporation

Volume 25

December, 1948

Number 4

CONTENTS

	PAGE
FERDINAND BRAUN—INVENTOR OF THE CATHODE-RAY TUBE	319
<i>By George Lewis and F. J. Mann</i>	
THE STORY OF COPPERWELD	328
TRENDS IN MILITARY ELECTRONIC-EQUIPMENT DESIGN	334
<i>By Norman H. Young</i>	
DEVELOPMENT OF SINGLE-RECEIVER AUTOMATIC ADCOCK DIRECTION-FINDERS FOR USE IN THE FREQUENCY BAND 100-150 MEGACYCLES PER SECOND	337
<i>By R. F. Cleaver</i>	
NOTE ON A SHORT-RANGE POSITION-FINDING SYSTEM USING MODULATED CON- TINUOUS WAVES	363
<i>By R. F. Cleaver</i>	
DESIGN OF AN IONIZATION MANOMETER TUBE	373
<i>By David L. Hollway</i>	
LONG-DISTANCE TELEPHONE COMMUNICATION CIRCUITS	386
<i>By A. W. Montgomery</i>	
EVALUATION OF TRANSMISSION EFFICIENCY ACCORDING TO HARTLEY'S EXPRES- SION OF INFORMATION CONTENT	414
<i>By A. G. Clavier</i>	
RECENT TELECOMMUNICATION DEVELOPMENTS	421
IN MEMORIAM—J. E. KINGSBURY	422
CONTRIBUTORS TO THIS ISSUE	433





A.-B. Standard Radiofabrik plant in Ulvsunda, Sweden. A wide range of radio equipment is manufactured and includes transmitters and receivers for numerous types of service, vacuum tubes for special purposes, and selenium rectifiers.

Ferdinand Braun—Inventor of the Cathode-Ray Tube

By GEORGE LEWIS and F. J. MANN

International Telephone and Telegraph Corporation, New York, New York

IN 1897, Professor Ferdinand Braun, then at the University of Strasbourg, published the first description of the cathode-ray tube.¹ It is characteristic of Braun's whole life and career that the fiftieth anniversary of this invention, said to rank second only in importance to de Forest's audion in the fields of communications and physics, passed without a single public reference to it or to its inventor. This, even though today television is making most rapid strides and the one indispensable component of all television receivers is the cathode-ray tube—or Braun tube as it was originally named.

Cathode-Ray Tube

Braun developed the tube to investigate high-frequency phenomena. Arranged as an oscillograph, this tube provided a means of representing the passage of currents and voltages in respect to time at higher frequencies than were possible with the then-available loop oscillograph, the inertia of whose moving coil limited its upper-frequency range. The cathode-ray tube has proved applicable to all electrical fields in which rapidly occurring phenomena are involved, not only in high-frequency physics, but also in ionospheric research, television, and radar.

The method of producing the peculiar type of rays called "cathode rays" and the possibility of

deflecting them by a magnetic field were already well understood in 1897. Long before that time, exhibits known as "physical cabinets" traveled with side shows throughout Europe. They demonstrated the Crookes, Geisler, and Hittorf tubes. Although elementary textbooks of that period mentioned the deflection of cathode rays, no one before Braun had worked out a way of applying this knowledge to a useful purpose.

Besides being able to generate cathode rays and knowing that they could be deflected magnetically, Braun was aware that a cathode-ray beam would cause the walls of the tube, when suitably coated, to glow with fluorescent light. He reasoned then that, by concentrating

the beam and controlling its deflection, it could be made to draw figures and patterns in light. His tube differed from present-day cathode-ray tubes chiefly in that it employed a cold cathode. His own description² of the tube follows.

Fig. 4 indicates the approximate form and size of the tube. The method is based on the deflection of cathode rays by magnetic means (and, if desired, electrostatic means). K denotes the aluminium cathode, A is the anode, C is a diaphragm of aluminium or glass with a centre hole of about 2 mm. diameter, and D is a screen of mica or glass (the latter material is better for photographic purposes) provided with a coat of phosphorescent paint. In order to obtain a smaller speck of light, a second diaphragm may be provided, this diaphragm being placed some 20 cm. in front of C. The back of the cathode K is embedded in

¹ F. Braun, "Ueber ein Verfahren zur Demonstration und zum Studium des zeitlichen Verlaufes variabler Ströme," *Annalen der Physik und Chemie*, v. 60, n. 3; 1897.

² F. Braun, "Phase-Shifted High-Frequency Oscillations," *The Electrician*; January 19, 1906.



glass. The cathode ray deflects under the action of the earth's magnetism, but is given the desired direction by a small magnet placed near the tube. In order to deflect the cathode ray by the current under investigation, I provide a small coil (called "indicator" coil) which is placed near the diaphragm, and whose axis is at right angles to the tube

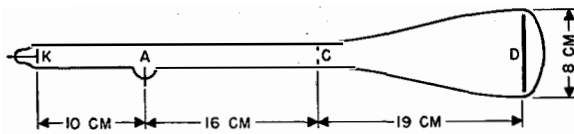

Copy of Fig. 4 from Braun's description of the original cathode-ray tube.

axis. Since the lines of force from this coil are divergent, thus leading to a distortion of the cylindrical flux of cathode rays (and to a speck of light more or less elliptical in shape), it is of advantage to employ two coils, one on the right-hand side and the other on the left-side of the tube. A more homogeneous magnetic field is secured in this way. Such tubes are supplied by Franz Müller (the successor of Dr. Geissler). They do not all turn out equally good. The dimensions given in Fig. 4 refer to one of my first tubes. Since that time the dimensions as also the form of the anode, &c., have undergone changes in a number of ways. When the oscillations are rapid and of a high voltage, the tube is surrounded near the diaphragm by moistened filter paper (or provided with a layer of glycerine) so as to prevent electrostatic effects which may otherwise become very troublesome.

Early Life

Professor Braun was born on June 6, 1850, in the little village of Fulda, principality of Hesse, Germany. Little is known of his early life except that he studied at the Universities of Marburg and Berlin. He left there with Quincke, with whom he was particularly friendly, to become his assistant at Würzburg. Later he became headmaster of the Thomas School in Leipzig. In this position, he also worked extensively in physics. He was one of the few secondary-school teachers of his time who had an enthusiasm for science and the energy to be active in this field despite a strenuous teaching career.

Throughout his lifetime, Braun was noted for his broad interests and simple, even democratic, tastes. He liked to travel and enjoyed painting and sketching. He loved to roam the Tyrolian Alps with his children and invariably he would draw on the backs of penny post cards comical sketches of amusing persons he met on these trips. After he had filled in droll captions for each sketch, he would mail them to his wife or friends back home.

On one such trip, an incident occurred that illustrates the rare and incisive humor that was always present even in classroom and serious conversation but which just bubbled over when he was on a holiday. On this occasion, he visited a small Alpine inn for lunch. Toward the end of the meal, he inquired if there were any chicory in the house. Two unopened packages were brought to him. He then asked if they had an opened package and that, too, was produced. "Now," said the professor with great dignity but with an amused twinkle in his eye, "will you make the coffee for us? I will keep the chicory here to insure that none gets into it."

Although Braun encountered many difficulties in life, his humor never left him. This probably explains his willingness to tackle the most exacting tasks and invariably to triumph over them. For example, he was tone deaf, but he gave brilliant lectures on acoustics.

Academic Rise Rapid

Braun received his first academic professorship in 1876 as professor of theoretical physics at Marburg. In 1880, he went to Strasbourg in the same capacity and then, in 1883, to Karlsruhe. At the time Braun was at Strasbourg, Kundt was working there. The two men had many things in common in relation to their scientific work and Braun was apparently in very good standing with the older man. From Karlsruhe, Braun went to



Birthplace of Braun at Fulda, Germany.

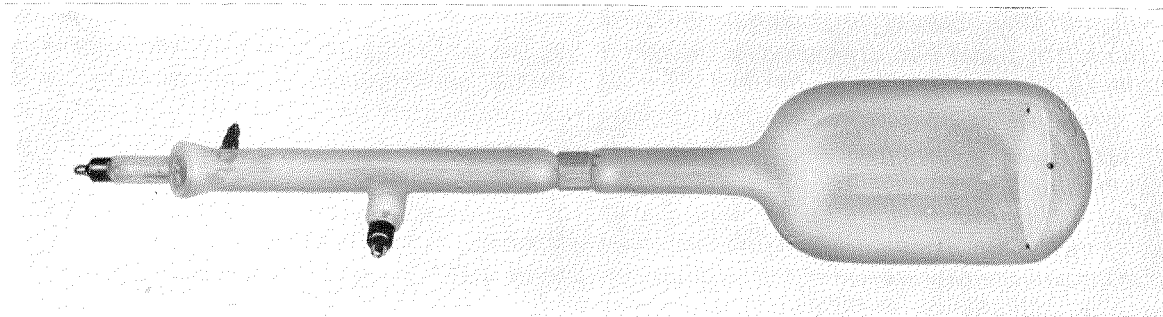

Photograph of an original type of Braun tube. The anode, in this type, was located in the side of the tube. An aluminum thimble located halfway between the cathode and screen provided the aperture that formed the beam. The fluorescent material was supported on a flat mica screen, the observer's side of which was divided into centimeter and millimeter squares. This tube is now part of the historical collection of vacuum tubes of R. McV. Weston.³

the University of Tübingen in 1885 as ordinary professor of experimental physics.

At that time, it frequently happened that a private lecturer, who became well known as a result of outstanding experimental work, or as a professor of theoretical physics, or who had published the results of theoretical investigations considered to be outstanding, became ordinary professor of experimental physics.

Braun's appointment to the University of Tübingen was based on his early work in physics. One of his first problems was that of explaining the interactions in galvanic elements. He correctly determined the method of computing electromotive forces from thermic data. Previous to his work, it was believed that the electromotive force of a galvanic element could be computed from the heat of reaction generated in the chemical process. The shortcomings of the old viewpoint were disclosed by Braun through certain theoretical considerations and also by measurements, which are still valid. The electromotive force may be larger or smaller than the value derived from the heat of reaction. To achieve a clear explanation, Braun applied the second law of thermodynamics in a paper that appeared in 1878. In 1882, Helmholtz treated the problem by introducing the idea of free energy.

Braun was also the first to investigate the dependence of pressure on electromotive force in a galvanic chain. This special problem was treated fundamentally by Gans at the Strasbourg Institute. Occupation with these problems

stimulated Braun to establish the Braun-Lechatelier principle. The principle did not prove valid in the general form in which it was expressed. However, Braun's work attracted attention because it contained proof that the treatment up to that time was based on an incorrect assumption.

Founds Institute of Physics

Braun's appointment to Tübingen involved a very responsible task for one of his youth, for he was given the assignment of setting up an institute of physics at the university. This assignment brought him, as it would no doubt have brought anyone in the same position, much joy as well as a great many difficulties. However, his efforts proved successful and he found much to enjoy at Tübingen.

Studies Electrocapillary Reactions

In 1891, he discovered a new electrolytic phenomenon he called *Electrostenolyse*. If current is allowed to pass in an electrolyte through a narrow slit, for example, the crack in a glass plate, an electrolytic deposition occurs at this slit like that at an intermediate electrode. This remarkable result was investigated carefully by Braun. In connection with this work and Bequerel's investigation, Braun looked further into electrocapillary reactions. These are reactions between two solutions that diffuse into each other through the pores of a porous wall which separates them.

At about the same time, Braun busied himself with phenomena involved in what were called *Tropfelektroden*. He indicated that Pellat's

³ R. McV. Weston, "A Museum of Electronic Apparatus," *Electrical Communication*, v. 17, pp. 133-142; October, 1938.

conclusion that there is no potential difference between the metal and a solution of its salt is incorrect. He gave consideration to the chemical reaction resulting from quicksilver dropping into liquids, or, as it would now be described, adsorption reactions. Further, he was the first who formulated the relation between volume change occurring in dissolving a salt in its saturated solution and the dependence of the solubility on pressure; also, that he placed this relationship on a thermodynamic basis. Braun further proved the interesting fact that compressibility of water in which certain salts are in solution is less than of pure water.

Braun was always primarily concerned with the consideration of principles. However, not only are his assumptions and results significant, but also the methods of his experimentation. He possessed an extraordinary talent and high originality in devising means of facilitating experiments. Consequently, his measuring arrangements and apparatus were of great interest and have been widely adopted in physical investigation and measuring technique. To give an example, in his study of the dielectric constant of rock salt for different crystallographic orientations, he described a simple electrometer. This ingeniously constructed instrument is notable for simplicity, convenience in handling, and low capacitance. Known as the Braun high-tension electrometer, it is still widely used. It is regarded as ideally suited for laboratory demonstrations.

Writes About American Indian

During this same busy period, although he won further honors with his serious scientific work, Braun must have found time to continue pursuit of his hobby of traveling, for he also undertook the task of writing a book about the American Indian. This was a work of juvenile fiction entitled *Conanchet oder Die Ansiedler in Connecticut* published in Leipzig in 1891.

When Braun reluctantly left Tübingen in 1895 for Strasbourg, the Mathematical Society of Tübingen presented him with a farewell gift, which indicated that his good humor and earnestness had won him many sympathetic friends during his decade there. The gift was quite unusual and resulted from his habit, particularly at lectures in physics, of estimating roughly a

result in advance or of calculating it, as he called it, "on pad and paper." In fact, the story is told that at one lecture he had to calculate 2×25 . He immediately set it down on "pad and paper" and went on with his lecture as follows: "Instead of taking 2×25 , we take 2×30 , the result should, therefore, be around 50." Fittingly, his farewell gift was a one-place table of logarithms to be used "to calculate on pad and paper."

Wins Nobel Prize

It was when Braun returned to Strasbourg that he began the research on radio communication that won for him, jointly with Marconi, the Nobel Prize awarded in 1909 in physics. Although it is generally remembered that Marconi received the Nobel Prize, few persons today realize that the Italian inventor actually shared this honor equally with the German scientist. Among the reasons for Braun's relative obscurity was his own attitude. He considered himself a scientist and not a publicist. He had no patience with pomp and show.

His democratic, simple attitude toward himself and his work is perhaps best illustrated by an incident that occurred while he was at Strasbourg. At the time, a chair became free at the University of Berlin and Professor Braun was asked to confer with the Chairman of Education. A professorship at this most important institution was then probably the highest honor to which any German could aspire. "Professor Braun, how would you like to come to Berlin and what are your conditions?", he was asked.

His characteristic reply was, "I do not know the value of money in Berlin. Where I am, I can walk downstairs to work and, if I want to work until midnight or until 2 A.M., it is not far to go to my bed. But, if I come to Berlin, I am told I would need a car and a chauffeur. Where I am I can take a third-class railway carriage to the mountains. In Berlin I would need a first-class carriage on an overnight trip for myself and my children. Thus, my conditions are: Can you match Strasbourg—match it in the time and freedom to work—match it in time and freedom to live, and in the atmosphere I love?"

Justification for Braun's share in the 1909 Nobel Prize is probably best given in the following excerpt from the speech addressed to him and Marconi on the occasion of the award.

Marconi's original arrangement had one weak point. The electric waves sent out by the transmitter were of comparatively small power and were composed of waves rapidly decreasing in intensity, so-called damped waves. For this reason, the influence of the waves on the receiving system was only small and the waves of different sending stations could disturb the receiving system. It is principally due to the intelligent and thorough efforts of Professor Braun that these difficulties have been overcome. Professor Braun changed the methods of producing electric waves in such a way that more powerful and less damped oscillations could be emitted. By this method only, was long-distance telegraphy rendered possible, as the waves thus transmitted were such that they could influence the receiving system in the most efficient way by means of resonance. The further advantage was gained by this new arrangement that mainly waves of the frequency of those emitted by the sending station could have an effect on the receiver. The great successes in wireless telegraphy that we have witnessed during the past years could be achieved only by the introduction of this new method.

Early Work in Wireless Telegraphy

About 1898, Braun was approached by members of the Stollwerck family, famous as chocolate manufacturers, for advice regarding an opportunity to invest in a new wireless company. He proved that the company had been formed around a scientific fake. These investigations stimulated his interest in the then new science and eventually led him to the discoveries and improvements credited to him. He invented the so-called closed circuit for radio transmitters and receivers. He also received credit for the substitution of the crystal detector for the clumsy coherer and he carried on pioneering experiments with loop antennas.

At the time when Professor Braun began his work on the problems of wireless telegraphy, popular interest in the subject had reached its peak. As early as 1865, Maxwell had published his paper "On a Dynamical Theory of the Electromagnetic Field" in which he stated the belief that electric action is propagated through free space in the form of a disturbance that travels with the velocity of light. In 1888, Hertz published an account of his experiments on the electromagnetic effects of rapid electrical oscillations and showed that the result of such oscillations was the propagation through space of periodic disturbances that had the characteristics of wave motion. Two years later, in France, Branly used a tube containing iron filings, the coherer, as a detector for Hertzian waves. In

1892, Crookes delivered a lecture predicting long-distance wireless communication using Hertzian waves.

With so many leading scientists approaching and predicting actual transmission of messages without wires, it was natural that interest should grow in intensity. What was also likely from such a situation actually happened; persons with little or no scientific knowledge were eager to put wireless telegraphy on a useful, paying basis. Still, scientists continued to approach the practical realization of their dreams. In 1894, Lodge provided Branly's coherer with an automatic tapping device or decoherer, which improved its usefulness as a detector of Hertzian waves. In 1895, Professor Popoff utilized the coherer with the Lodge "tapper" and a relay, together with an antenna wire and ground, for the detection of lightning and static. About this apparatus, Professor Popoff wrote⁴ in December, 1895:

I entertain the hope that when my apparatus is perfected it will be applicable to the transmission of signals to a distance by means of rapid electric vibrations—when, in fact, a sufficiently powerful generator of these vibrations is discovered.

Scientific Versus Cut-and-Try Experimentation

At about the same time, Marconi was making transmitting tests with a Righi oscillator and attached antenna. For receiving, he utilized an arrangement essentially similar to that of Popoff. As early as 1896, Marconi was actually sending messages with this apparatus over distances of several hundred yards and on New Year's Day of 1898 he transmitted 18 miles to a tugboat from Needles on the Isle of Wight, using a transmitting antenna 120 feet high. A year earlier, Professor Slaby of the Berlin Institute of Technology claimed to have transmitted approximately 34 miles over land using an antenna 300 meters long carried by balloons. However, these experiments were merely of the cut-and-try variety. For example, during one of Marconi's trials, he spent two fruitless days trying to get his apparatus to work. Then he added 20 yards of wire to the antenna and signals were received perfectly. Since Marconi at that time used no tuning apparatus,

⁴J. J. Fahie, "A History of Wireless Telegraphy," 2nd edition, Dodd, Mead and Company, New York, 1902; p. 205.

the additional wire probably brought the receiver closer to resonance with the transmitter.

At this point it was clear that a knowledge of the basic principles involved was essential. Braun in his characteristic, scientific, tireless manner set out to determine these fundamentals. No one at the time knew exactly what was happening. For instance, no one knew the wavelength or oscillating frequency of the waves generated by the Marconi transmitter. It was thought that very short waves of the order of one meter were generated by the spheres of the spark gap in the Righi oscillator.

Braun recognized that this could not be correct. He reasoned that the antenna, which was grounded through the spark gap, should be considered as a whole. The Marconi transmitter, therefore, did not operate with Hertzian waves in the narrow sense, but with much longer wavelengths. This view, which now appears self-evident, was then by no means universally recognized.

It is also of significance that Braun approached the whole problem as a scientist. He seemed to have no patience with the practice prevalent among some contemporary researchers of developing radio as one would bake a pie, that is, by adding something here or modifying something there, but without investigating the principles involved or measuring experimental results accurately. Braun belonged to the small group of excellent theoreticians and physicists to whom the really basic and fundamental radio developments and discoveries should be credited. They were tireless, exacting workers who shunned publicity. Consequently, their less-scientific but more-voluble contemporaries often overshadowed them in public recognition. However, the many fine laboratories now in operation throughout the world, some of them shiny with newness, where emphasis on scientific methods has and will continue to produce remarkable advances in radio and electronics, are perhaps more fitting monuments than dubious publicity to the type of leadership Braun represented.

While Braun insisted on measuring his results and checking his theories quantitatively, at the time very little laboratory equipment was available to measure rapid oscillations and feeble currents. Measuring methods for direct or commercial alternating currents were not applicable

in the radio-frequency spectrum. In principle, the application of resonant phenomena for measurement applications was known since Bjercknes, but these new methods had to be arranged fundamentally for the newer art. It was precisely to make such measurements that Braun developed the cathode-ray tube.

It is a further tribute to Braun that he surrounded himself with capable men who were able to follow his demands and provide much needed apparatus and help in developing techniques. Men like Cantor and Professor Zenneck, who later became important researchers in their own right, were his able assistants. They enjoyed a sense of freedom and naturalness that went a long way toward instilling the devotion and tirelessness that was even more precious to Professor Braun than the respect he received. No better proof of this can be given than to relate that often Braun would go to the bedroom of one of his assistants, sit down on the bed, and informally discuss the matter in hand. It was not that his assistants were all bedridden by illness, but, in the intensity of their work, they often lost all track of time, working through the night and sleeping in the daytime.

Always most considerate and kind, it seemed the most natural thing to Braun to visit an assistant if he had not shown up in the laboratory. At such times, Braun was prone to intersperse his technical description with jokes that he made up as he unfolded his latest scientific views.

Application of Closed Circuit

At the time of Marconi's work with the Righi oscillator, a means for generating long-wave oscillations—the so-called condenser circuit—had been developed. The oscillatory charges of such circuits had been investigated by Feddersen as early as 1862, and later Lodge made resonance experiments with them. Braun immediately recognized the advantages of applying condenser circuits to radiotelegraphy. He reasoned that the wireless-telegraph transmitter presented two types of problems. First, the strongest possible high-frequency alternating current had to be generated and then this current had to be converted to radiation, i.e., to electromagnetic waves. The Marconi transmitter operated with an open oscillatory circuit,

which acted as a good radiator, but which imposed definite limitations on the generation of power. The condenser circuit radiated poorly but permitted strong high-frequency currents to be generated. By combining both, the renowned Braun coupled transmitter was achieved. In its original form, it consisted essentially of the condenser circuit with the spark-gap path driven by an inductor, coupled directly or inductively to an antenna that contained no spark path. As is well known, the oscillations in the condenser circuit generated current in the radiating antenna.

Regarding the importance of Braun's discovery, one can in most cases consider it as characteristic of a basic invention that its importance usually extends far beyond the immediate application for which it was created. This applies to the Braun condenser circuit. The whole technique of radio transmitters has, since Braun's introduction of the closed circuit, seen many variations. The transmitter with the strong spark came first, then the Wien transmitter employing the fundamental discovery of the quenched spark. While in the Marconi spark transmitter, it was possible to use the open circuit, with the Wien transmitter the closed circuit was indispensable. Then came the era of undamped waves with first the Poulsen arc, later the Alexanderson alternator, and finally the vacuum-tube transmitter. All of these later methods of transmission employed the closed circuit almost exclusively.

An analogous observation applies to receivers. Braun not only applied the principle of the closed oscillatory circuit to transmission but he also developed the coupled receiver, which employed the same principles. Methods of reception have also undergone a great variety of modifications in the course of time. The application of the vacuum tube brought about a radical change and provided possibilities that could not have been anticipated in the early period. But, as with the most modern transmitting arrangement, the application of the closed condenser circuit proved to be one of the best and most useful means for achieving the highest possible selectivity.

Thus when, in radio, coupled oscillatory circuits are associated with Braun's name, there is full justification for this identification. For while it is true that the condenser circuit as an electrical oscillatory system was known long before radio communication, it is undoubtedly to

Braun's merit that he appreciated its significance and introduced it in a practical form.

Braun's Assistants Develop Wavemeter

Using Braun's ideas, his assistants worked out basic measuring techniques for wireless telegraphy. They led to the first practical Köpsel-Dönitz wavemeter, which consisted of a tuned circuit employing an inductor, calibrated capacitor, and thermic current indicator. To this day, the wavemeter has remained unchanged in principle.

In the same class is the cathode-ray tube. About it, Zenneck writes:⁵

When Braun brought out his tube, I was very enthusiastic about it. It was exactly what I had wanted for a long time, a device with which one sees what is going on in the current circuit. Later, I considered it a sport to discover as many possibilities of application as possible.

Probably the first and most important contribution Zenneck made to the development of the Braun tube was the introduction of the saw-tooth wave that electronically changed the one-dimensional straight-line back-and-forth figure of the cathode-ray spot into a two-dimensional amplitude-time curve. Braun had used a moving mirror to obtain this effect and later the spot was photographed on a film or plate that was moved with uniform velocity perpendicular to the direction of the motion of the spot. Both of the earlier mechanical methods limited the frequency that could be examined, while the Zenneck electronic method was almost limitless. It is, in fact, the same method as is now used in television scanning.

Braun Works with Crystals

As early as 1874, Braun published a report on investigations he had made of certain low-conductivity crystals. He discovered that if he passed an electric current through copper pyrites, sulphur pyrites, galena, "fahlerz," and similar crystals, he found that the strength of the current was not proportional to the electromotive force. If, in addition, the electrodes were constructed differently, the current strength was also dependent on the direction of the applied potential difference. Braun, in his first experiments, for

⁵ J. Zenneck, "To the Fiftieth Anniversary of the Braun Tube," Unpublished.

example, encountered differences in strength of 30 percent depending on the direction of current flow. In later arrangements, the difference in current strength was still greater so that, practically speaking, it could be said that the current was conducted in only one direction. This deviation from Ohm's law is designated as unipolar conductivity or rectification.

Braun found an early application for it in the crystal detector, which he first used to receive wireless telegraph signals in 1899.

Before the crystal detector, the coherer was the only means of detecting radio waves. This remained an exceptionally critical and inconstant piece of apparatus not really satisfactory for practical use, despite the efforts and improvements of a number of inventors. Many investigators, therefore, earnestly sought a better detector. As with the closed circuit and the cathode-ray tube, Braun's crystal detector, which for simplicity remains unexampled today, achieved notable results. For a long time in fact, it replaced all other detectors and completely dominated this field until the vacuum tube was introduced. In recent applications of radar and ultrahigh-frequency operation, there has been a return to the use of the crystal detector as a simpler and even more efficient device than the vacuum tube. Also, Braun's originally discovered principle has seen wide application in metallic rectifiers for power frequencies. A recent development, the transistor, applies the principles of semiconduction to the amplification process, thus completing the circle. The vacuum tube supplanted the crystal detector. Then many new applications were found for the vacuum tube. Now it is predicted that the transistor, which is little else than a more advanced crystal detector, will supplant the vacuum tube for many of its applications, including amplification and oscillation.

Experiments with Directional Radio

Another field pioneered by Braun was that of directional transmission and reception. As early as 1902, he made successful trials with an antenna inclined about 10 degrees from the horizontal, showing it to be more sensitive to waves received from a single direction. From this type, a specific class of receiving antennas was constructed and included the inverted-L and the horizontal or earthed antennas. Similar antennas were pro-

posed for transmission, but for this purpose their directivity proved very low.

Braun attacked the problem of directive transmission differently from that of reception. The principle of his method was to employ two or more separated vertical wires. In the initial experiments, he employed three wires set at the corners of an equilateral triangle.⁶ The wires were supplied with currents differing in phase. Phase displacement and separation distances were chosen so that the wave was beamed in a desired direction. Such trials were made in Strasbourg in 1904. Field strength was measured with a bolometer. Results were as had been predicted theoretically. It is, of course, commonplace now to use such methods of directional transmission, particularly for the higher frequencies.

In 1913, Braun again took up the problem of directive reception. At this time he experimented with loop antennas and was, no doubt, prompted to employ this method of directional reception by the fact that the vacuum tube then offered a more sensitive means of detection than the crystal detector and could also be employed as an amplifier. The advantages of directional reception such as reduction of interference, a greater signal-to-noise ratio, and direction indication were recognized as possibilities by Braun, although their full utilization did not come until later. During these experiments, which Braun conducted in Strasbourg with signals received from the Eiffel Tower, field strength of radio waves was measured to an absolute value for the first time. Today field-strength knowledge at a receiving point is considered indispensable and all modern methods of measurement are based essentially on the early Braun arrangements.

Visits America

When World War I broke out, a patent suit was brought against the Sayville, Long Island, radio station, which worked with a station at Nauen, near Berlin. The purpose of this suit was to close the Sayville station and thus cut off all means of communication between Germany and the U. S. A., the cable between these two countries having already been cut. Braun was asked to appear in New York to testify regarding ex-

⁶ F. Braun, "On Directed Wireless Telegraphy," *The Electrician*, May 25 and June 1, 1906.

periments he had made. At the age of 64, with undermined health, he made the trip in mid-winter through the British blockade, because he hoped in this way to be of service to his country.

The suit was indefinitely postponed and Professor Braun stayed on to live at his son's home in Brooklyn, New York. There were no means by which he could return to his laboratory in Strasbourg and later, when the U. S. A. entered the war, he would not have been permitted to return. He was suffering from an incurable illness and was, perhaps, saddened by the fact that the great nations, all of which he seemed to love, were at war. At least, he had shown enthusiasm over the New World after he had returned to Germany from a trip made in 1909 across North America as far as Vancouver, British Columbia. At that time, he gave an illustrated lecture on his impressions of America. He even built a miniature shoe factory that operated on a high-speed conveyor-belt plan just as he had seen on his trip. He fed in small strips of leather belt at one end and, pronto, out came miniature shoes. To illustrate the wonders of Yellowstone Park, he made a model of the area in contour and color. Even "Old Faithful" was represented in the form of a geyser of carbonated water.

Now these happy memories were far in the past. Not only was Professor Braun very ill, but, for the first time, he was forced to be away from his laboratory for an extended period of time. A quick holiday to the mountains was one thing. A jaunty vacation across the Atlantic had only left him with renewed vigor to return to his experiments. But a time had now come when he was confronted with months and months of idleness, an ill man. Even then he filled up some of this time by giving piano lessons to children who could come to his Brooklyn home. And it was while shoveling snow that he suffered the accident that finally caused his death. He fell on the ice and broke his hip. For weeks he lay in bed in pain and then complications set in. He died April 20, 1918. His body was cremated in New Jersey and, after the war was over, his ashes were returned to his native Fulda and buried next to the grave of his parents.

Tributes to Braun

Few men of science have achieved as much as Ferdinand Braun. Also, rarely has a man who

has accomplished so many great things also been so loved and respected. He possessed a naturalness which, along with his friendliness and exceptional good will, made him extremely well liked among his associates.

No more fitting tribute to this quality of Braun can be given than to quote the following statements by men who worked with him and knew him well. The first was written by Mandelstam and Papalexi.⁷

As a teacher, Braun is unforgettable to all who were privileged to work in his institute. He left it to each one according to his individuality to follow his inclination. He followed all work constantly with interest and was always ready with advice and help. And his advice was more than clarifying: Braun had the vision and sensitivity of an experimenter that cannot be learned and with which only the chosen few natural researchers are gifted. These qualities to which, to a large degree, he owes his success as a researcher benefited also his students. . . . Braun's capabilities as a research worker assure him a place of high honor in the realm of science, and all who had the good fortune to come in close contact with him will hold the memory of this great, experienced, intelligent, and good man in affection and the highest esteem.

More recently, Braun's former assistant, Professor Zenneck, now President of the Deutsche Museum in Munich, and recognized as a distinguished scientist and teacher in his own right, wrote⁴ of his former mentor.

Braun was a distinguished experimenter, who had thorough mastery of the experimental aids in physics. In his investigations, he always applied himself only to essentials. He had a fine instinct for what was essential in each case. A good example of this is that he undertook the experiments with the frame antenna right at the time when the amplifying tube entered the field and a widened application of this form of antenna was made possible. . . . Personally, Braun by nature was beyond reproach. . . . Despite all the difficulties which he encountered in life, his humor never left him. His witty remarks at lectures and in conversation were all the more effective because one could see his own enjoyment of them. As Director of the Institute, he was beloved both by the candidates for doctorates and by the assistants. In all, we assistants had in him a chief who advanced our scientific work in every respect and who regarded our individualities with kindly understanding. . . . Braun was what we would call a splendid man. I am convinced that all who had to work closely with him, remember him not only with respect but also with pleasure.

⁷ Von L. Mandelstam and N. Papalexi, "Ferdinand Braun—In Memoriam," *Die Naturwissenschaften*; August 10, 1928.

The Story of Copperweld

THIS is a story about wire—not ordinary wire. It is a story about a comparatively new and different wire, a wire that has successfully joined two great basic metals in a perfect union to carry power and man's voice to places all over the world.

This is also a story about the company that makes that wire. Not a large company, as industrial giants go, nor an old one in the sense of century-old enterprises. A company whose people for 33 years have lived and worked with one primary aim—to develop and improve a product that others had unsuccessfully tried for decades to develop.

The company began operations in 1915 with 23 workers. It now numbers its employes in the thousands and its product spans the continents of the earth. The product is a special kind of wire called “Copperweld” and the company is the Copperweld Steel Company.

1. *The Art of Making Wire*

The story begins at the dawn of history, some 3700 years ago. Making wire for ornaments, tools, hooks, fasteners, for a score of other uses in a primitive world, was one of the most ancient of metal-working arts. The wire maker was one of the most honored of metal craftsmen. Gold wire, a Pharaoh's necklace, is mentioned in the Bible. Samples of Assyrian and Babylonian wire have been found dating back to 1700 B.C. Almost nothing is known of this early manufacture, but the wire was probably shaped with hammers.

Two thousand years ago man made a discovery that was, in its field, comparable to the discovery of the principle of the lever, to the invention of the wheel and the windlass. He found that a hammered brass rod could be made smaller and smaller by being pulled through a tapered hole in an iron plate. Thus the principle of the draw plate was born and the first wire was drawn.

A Latin manuscript written by Theophilis sometime in the 8th or 9th century describes a method of making wire of an alloy of lead and tin. The alloy was cast into an ingot and then hammered into a long bar. The pointed end of

the bar was forcibly drawn through a series of holes set in a draw plate. In this way, the cross section of the rod was gradually reduced to that of the last hole through which it was drawn, its length being correspondingly greatly increased.

Some scholars believe that the chain armor used by the knights in the great crusades against the Saracens and the Turks was made of drawn, rather than hammered, wire.

The earliest known mention of commercial wire drawing was in 1351 and again in 1360. In that time, in the now-ruined cities of Nuremberg and Augsburg in Germany, the wire *smith* was joined by the wire *mill*. In this early manufacture, the wire miller attached the end of the wire to a belt around his waist and pulled it through the draw plate, a few inches at a time, by stepping and falling backwards. A windlass type of pull was introduced a few years later, followed by an application of water power.

Until 1565, English iron wire was drawn by hand only, with such poor results that almost all wire was imported from Germany and Holland. The first wire mill in England was set up by Dutch manufacturers in 1662.

A “wyer drawer” named Nathaniel Robinson, who set up a mill at Lynn, Massachusetts, four years later, is the ancestor of the American wire industry. But 168 years later, in 1834, there were only three wire mills in the 24 states of the union, with a total output that year of 15 tons. Wire, which was later to be known as “the product with 1500 uses,” was still being applied to but a few basic needs.

Then, within 40 years, two things happened that revolutionized industries and changed the face of America. Wire changed from a product of few uses to become the thong and tendon that bound the land together.

In 1844, S. F. B. Morse built a telegraph line from Baltimore to Washington, a distance of 40 miles, and then laid down a line to connect those two cities with New York. Seven years later more than 50 companies were operating under Morse's telegraphic patents. In that same decade, a cable was laid across the bed of the Atlantic Ocean.

On March 10, 1876, Alexander Graham Bell spoke a few words, which were to affect every man, woman, and child in the land. To his assistant, who was listening in the next room at the end of a wire, he said, "Mr. Watson, come here, I want you."

By 1878, New Haven had a telephone switchboard with 21 subscribers. By 1920, America had spun a wire network that encompassed 20 million telephones.

In the meantime, in 1890, the first power station went up. Distribution of electric power was becoming a major U.S.A. industry. Electric power was being carried up and down the land.

These new industries needed wire, millions of miles of it. Much of that wire had to be copper. This brilliant metal had been used by the human race to make its first weapons in remotest antiquity. It was the metal which, joined with tin to form man's first metallic compound, had given

a name to the Bronze Age. Now this metal had been found to be the best commercial conductor of electrical energy.

But as distances increased, industry needed and hoped for a special kind of wire that would have the one thing copper lacked, strength. To carry electrical energy, it needed a wire strong enough to withstand great tensions, and which would not corrode. The wire must carry power and voices many hundreds of miles. It must span great rivers and valleys.

2. Search for a Perfect Metal

The metal which would make such a wire simply did not exist. Steel was strong enough. But steel was not a good enough conductor, and it corroded. Copper was an excellent conductor and did not corrode. But copper was not strong enough. It had no backbone.



Basic to the Copperweld process is the pouring of molten copper around a heated alloy steel billet centered in a mold. The resulting ingot is reduced by hot rolling and cold drawing to final wire size.

Could the metallurgist combine the two into a wire that would be strong, durable, and conductive? If he could, time and money might be saved in power and communication lines. Distances might be spanned that were impossible for copper wire. The space between supporting structures might be increased from a few hundred feet to a mile or more.

Coating iron with copper was by no means a new idea. The ancient Swiss lake dwellers and certain tribes in Assyria, we now know, had made tools and weapons with an iron core and a copper-alloy covering. An English metallurgist had patented a copper-iron combination in 1821. He melted copper in a shallow cast-iron vessel and applied it to iron pans. His pans were tough, and the copper lining kept them from corroding.

Many men tried to create a steel and copper wire. The first attempt was made in 1860, when two American metallurgists wrapped steel wire with copper strips and then tinned the result. They failed.

Various methods of merging steel and copper by casting followed. In 1885, a Frenchman made a composite billet which could, by careful handling, be rolled and drawn into wire. But the two metals were not joined by a weld; the copper served only as a shell over the steel core. Electrolysis and destruction resulted.

An electroplating process was developed, tried, and discarded because the copper-plated wire rusted.

The Duplex Metals Company, organized in 1905, found the key. That was to *weld* steel and copper together. Their method, the Monnot process, consisted of dipping an especially prepared steel billet into a copper bath, thus *wetting* the steel with the copper. The *wetted* steel billet

was then placed in a mold containing molten copper to form a copper-clad ingot.

Five American men with vision then joined forces to take the next big step. Founding a firm named the Copper Clad Steel Company, they invented what is known as the Copperweld process of welding steel and copper. This process, less complex than previous methods, was based primarily on obtaining a *molten weld* between copper and steel.

Steel and copper were now at last merged into a weld so strong that they could not be separated except by destruction of the bimetallic material itself. The next step was to develop processes by which this material might be drawn into bimetallic wire. That was no simple matter. There is a wide difference in the melting and rolling temperatures of these ferrous and nonferrous metals. There are differences in malleability and in temperature coefficients of expansion.

In 1915, the company, now renamed the Copperweld Steel Company, and its 23 employees began the first actual production of a usable wire with a tough steel core and a uniform rust-resisting conductive copper covering. That first wire was found to be satisfactory in every respect.

Research and development of skills over the past three decades have enabled metallurgists to improve the manufacture of bimetallic wire, to lower its cost, and to speed up and simplify its production. Steel and copper can now be maintained in exact proportions down to wire thinner than a hair. And yet the original process was so sound fundamentally that it has remained the basis for any product improvement today.

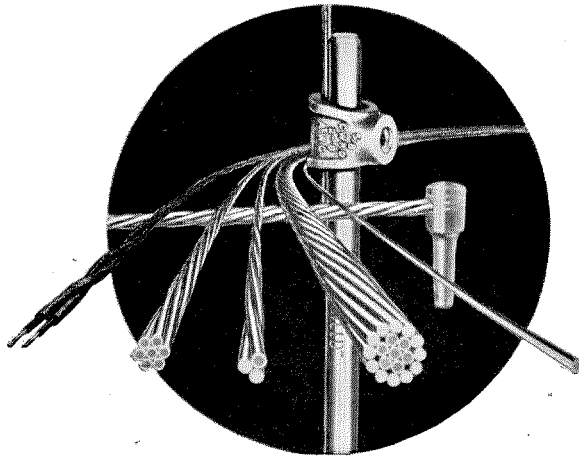

Samples of Copperweld products. The cables from left to right are telephone drop wire, strand, two types of power conductors, and telephone line wire. A ground rod with connecting wire clamped at the top is the vertical assembly and the horizontal cable with a plug-type terminal is a railroad signal bond.

3. Copperweld Process

The process that welds copper to steel and produces bimetallic wire takes place in a half dozen major steps.

Alloy steel billets, about six inches in diameter and four feet long, are picked up by a magnetic crane, cleaned and inserted exactly in the center of a cylindrical graphite mold, which is approximately eight inches in inside diameter. The mold is then placed in a furnace. When the steel billet inside it has reached welding temperature, the mold is removed from the furnace.

Molten electrolytic copper, heated to the proper temperature, is poured into the space between the steel billet and the inner mold wall. It is at this moment that a molten weld is produced between the two metals. Actually, the copper grains diffuse between and into the steel grains, interlocking and joining the two metals into an unbreakable uniform weld.

This weld, a form of iron-copper alloy which is much stronger than copper alone, is the basic factor that permits exacting fabrication. Without the successful weld, the billets would fail during the rolling process that follows. The finished product, moreover, would not be able to withstand the tensional and torsional stresses that a conductor receives in service on overhead lines.

When the copper has been poured, the molds are withdrawn from the pouring bay and allowed to cool. The billets are removed and placed in a preheating furnace and heated to a rolling temperature. That rolling presents a unique problem. Since copper melts at approximately 2000 degrees Fahrenheit, the billet must be rolled at a temperature well below the standard rolling heat for steel. Specially designed rolls reduce the billet without destroying the properties of copper and steel and maintain the original proportions and concentricity of the two metals.

The first rolling operation takes place on a 24-inch water-cooled tilting-table mill. An operator passes the billet between the rolls. As it reaches the opposite side, the table tilts and a second operator guides the billet between another set of rolls. This operation continues until the billet has been reduced to a bar with a diameter of from two to three inches.

Since the bar has become considerably longer in this rolling, it is cut in half. It is then reheated

and passed through a series of smaller rolls to be formed into a rod, which is finally reduced to a diameter of three-eighths of an inch and coiled.

Next step is to transform the rod from its hot-rolled structure to a fine-grained molecular arrangement, a structure that is important in the product's use as an overhead conductor. The rod is fed from payout reels into two sectional heat-treating furnaces. It is heated above its so-called critical temperature and quenched in water.

The rod is then cleaned in a mild sulphuric-

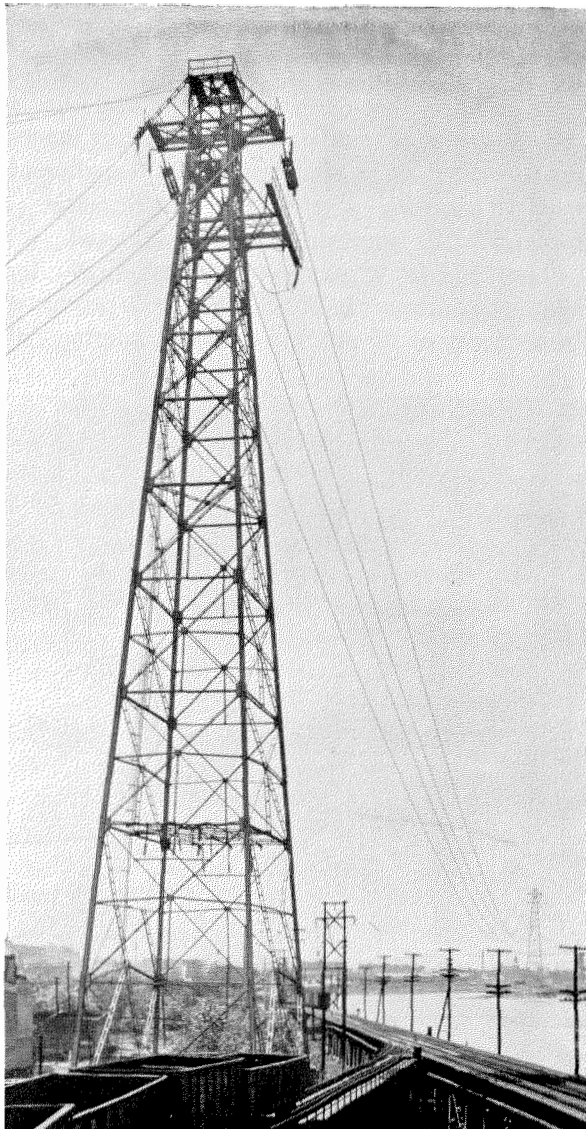

Copperweld conductors, installed in 1927, are providing dependable service on this 3300-foot river crossing.

acid solution, which dissolves the copper oxide but does not affect the copper. It is now ready to be cold drawn into wire.

The drawing process has two objectives. It reduces the wire to a practical size for use either as a single or a multistrand conductor; and it increases the tensile strength by cold working.

The cold-drawing operation involves special techniques, yet generally is similar to methods used in drawing copper or steel individually. In particular, the slope and curvature of the dies and the speed of drawing must be closely controlled. The operation begins on huge seven-die wire-drawing machines.

In multiple drawing, the wire is pulled through a single die onto a drum. From here it passes over an idler, through a second die, and onto a second drum. A number of such drawing stages are provided on a single machine. Equipment used in drawing wire to the smaller sizes is essentially the same, differing only in detail.

The finished wire may be coiled singly for shipment or it may be stranded. Wire is produced in as many as 37 strands. Smallest commercial

Copperweld wire normally made is Number 20 (0.032 inch), though it has been successfully drawn down to two thousandths of an inch.

Extensive improvements in strength have taken place in the past three decades. The earlier wire had a tensile strength of 80 to 100 thousand pounds per square inch. In 1920, by use of improved steels, wires were produced having tensile strengths ranging from 120 to 140 thousand pounds per square inch. About 1930, the development of special alloy steels made it possible to manufacture wire having strengths up to 180,000 pounds per square inch.

Improvements in the art of rolling make possible a guarantee of minimum copper thickness as well as a guarantee of minimum conductivity. "Thirty-percent" wire has an electrical conductivity equal to 30 percent of the conductivity of a solid copper wire of the same diameter, with a minimum copper thickness of 10 percent of the radius of the finished wire. "Forty-percent" wire has an electrical conductivity not less than 40 percent of a solid copper wire of the same diameter, with a minimum copper thickness of 12.5 percent of the radius of the finished wire.

Along with improvements of the wire, special tests and inspection practices have been developed and cover such properties as torsion, weld, conductivity, surface, breaking strength, and elongation. These tests are continuous from ingot to finished wire. Methods and equipment have been devised for measuring the copper thickness at any point in a coil without destruction of the wire.

4. Copperweld Wire at Work

Copperweld wire varies in size and strength depending on the use for which it is intended. These wires are widely used by electric light and power companies for overhead ground wires on transmission lines, for pole guys, and as messengers for supporting aerial power cables. They are used in various combinations with copper wires as power conductors.

The telephone industry uses this wire extensively as "drop wire" for connecting the subscribers' premises to the company lines, for line wire on open construction, for guying, and for aerial cable messenger.



Along the right-of-way of a leading railroad where Copperweld plays an important part in the operation of the signal system.

Railroads use Copperweld signal bonds to complete the electrical circuit from rail to rail. They use signal line wire, guy and messenger strand, and overhead ground wire. Electrified roads use Copperweld-Copper catenary messenger as a combination conductor and trolley-wire support.

Similar composite Copperweld-Copper conductors are used for extremely long spans of transmission lines crossing rivers and valleys, often with a distance of a mile or more between supporting towers.

With the advent of rural electrification in the United States, there was developed a high-strength, low-cost conductor made of one non-rusting Copperweld "strength" wire and two copper "conductor" wires in the form of a three-wire strand. Hundreds of thousands of miles of these conductors in service have been a continuing factor in reducing the cost of rural lines.

Copperweld ground rods and clamps are used in all of the above fields. The corrosion-resisting and easy driving properties of the ground rods make them almost a "must" in every type of electrical work where a driven ground is needed to provide positive grounding protection.

Such are some of the uses of Copperweld wire in the company's primary fields of application: utilities, railroads, and communications. Many new uses have developed in the past few years.

Perhaps the most interesting of these is a unique construction application being employed by the U. S. Army engineers on various flood-control projects. Here Copperweld's permanent strength and corrosion resistance provided the solution to the serious problem of reinforcing-wire failure in concrete revetment mattresses for levee protection.

Reinforcing wire previously used in these installations eventually failed because of corrosive action of the water. Result was that the concrete forms would crack and sometimes give way against the force of the current.

After exhaustive tests, Copperweld proved entirely resistant to the corrosive action and has since been specified for use in reinforcing and tying together articulated concrete flood- and erosion-control mats.

Fabrication of wire into "revetment mats" consists of a series of bending, welding, and stapling operations. These are made so that the

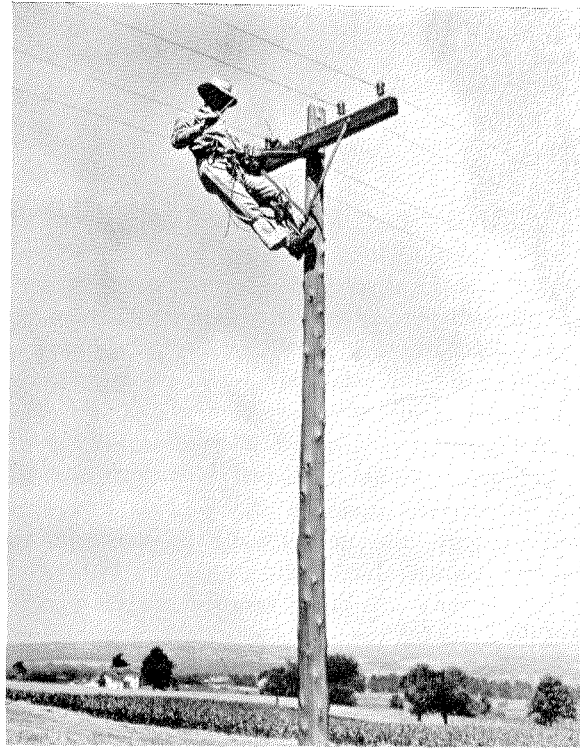

Lineman installing a Grip-Flax tie on a Copperweld telephone wire.

wire reinforcement network can be extended in any direction by stapling.

Throughout World War II, Copperweld wire served in every theater and in every battle zone. The U. S. Army Signal Corps, in fact, strung enough Copperweld telephone wire across the battlefields of Europe and the South Pacific to encircle the world 20 times. Along the Alcan highway, enduring some of the world's severest weather, more than 10,000 miles of Copperweld telephone wires have been carrying the weight of wind and ice since 1942.

Such is the story of Copperweld wire and of the company that developed it and makes it. As the network of power and communication systems grows greater and greater, Copperweld engineers envision new horizons for a product that has been an integral part of the electrical industry for a third of a century. Where the basic requirements are the combination of strength, durability, electrical conductivity, and rust resistance, Copperweld has an indisputable performance record. It is pledged to continue and expand that record.

Trends in Military Electronic-Equipment Design

By NORMAN H. YOUNG

Federal Telecommunication Laboratories, Incorporated, Nutley, New Jersey

THE SPECIFICATIONS furnished to development laboratories by the armed services as part of their procurement program display a steadily varying pattern as the needs of the services and available techniques to meet these needs change. These variations sometimes reflect the requirements of an individual tactical problem, but on examination of many specifications a general pattern of growth toward certain goals is discernible. For this achievement, the government is prepared to expend considerable effort.

While some of these targets are of purely military usefulness, others reflect commercial considerations of great importance, and their significance will increase as techniques are improved under the stimulus of the military development program. All engineers, therefore, whether engaged in government-sponsored programs or not, should examine their activities with care to see that these trends are grasped as quickly as possible and turned to use wherever they fit the program.

1. Detailed Analysis of Trends

One common spirit pervades the entire development program. In essence, it is the heart of all technological improvement. This is best expressed as a vigorous impatience with all the inconveniences and shortcomings of the apparatus at hand and the endless repetition of the question: "Why isn't it perfect?" All the characteristics to be considered arise from the desire to have electronic servants of zero size and weight, responding with infallible accuracy under all conditions imaginable. The degree to which an engineer refuses to accept *any* limitation as necessary or incapable of improvement, is directly a measure of his conformity to the spirit of this program.

1.1 MINIATURIZATION

Military operations invariably place the maximum burden possible on available means of

transport. Space and weight are equally at a premium on the person of an advance scout or in the hold of a supply vessel. Therefore, components are being developed that open new possibilities in the way of space and weight reduction. The trend from so-called "standard" tubes to "miniature" types is well advanced in commercial design, and in military apparatus the use of "subminiatures" should always be reviewed in the light of the specific problem at hand.

Miniaturization brings with it additional problems of heat dissipation for it is not always possible to decrease the power handled by the apparatus. These difficulties may be overcome in some cases by the application of special components and materials, permitting a much greater rise in operating temperature over the surroundings than has been generally used in the past. For example, the use of glass insulation in transformers has permitted unusually small units to operate at a much higher temperature than was possible in former designs.

1.2 UNITIZED CONSTRUCTION

Unitized construction hits at another facet of the problems in military equipment. Electronic apparatus that fails in the field must either be so easy to repair that relatively untrained personnel can restore it to a guaranteed level of performance, or must be capable of being completely replaced; the defective units either being discarded or returned to a major base for repair and adjustment. In particular, it must be impossible for the operator partially to repair an equipment so that it apparently operates, but is actually presenting erroneous information.

The only equipment that can be serviced in the fashion outlined is one in which each major component or subassembly is complete in a self-contained unit, usually "plug-in" and hermetically sealed. The sockets for a group of such plug-in assemblies can be made sufficiently rugged to insure very great dependability. Field servicing is then reduced to interchanging spare

units for defective equipment until normal operation is restored.

1.3 INCREASED RELIABILITY

While the need for absolutely dependable equipment has always guided designers of military apparatus, one important change in techniques throws special emphasis on this

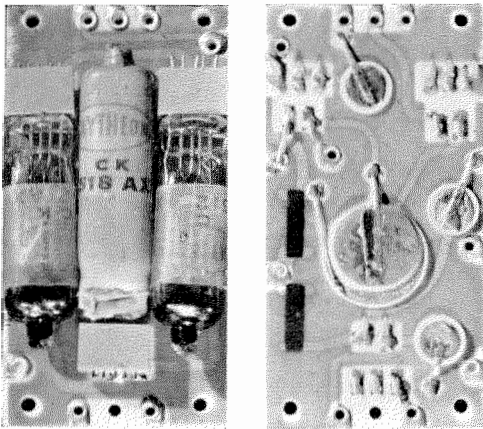

Full-size illustration of printed-circuit technique as applied to a miniature three-stage audio-frequency amplifier. Front and rear views are shown. The unit measures $1\frac{1}{8}$ by $2\frac{1}{4}$ inches. (Photo courtesy Centralab Division, Globe Union Corporation, Milwaukee, Wisconsin.)

problem. The increasing use of multiplexing to carry the heavy burden of military traffic means that the failure of one component in certain parts of an equipment may disable not one circuit, but dozens, or in the future, even hundreds of circuits. The use of unattended repeaters also imposes additional requirements of reliability.

From this situation arises a new concept of the "life" of apparatus. Most manufacturers rate the probable life of their designs on a basis of 50-percent failure, or in some cases 20-percent or 10-percent failure, averaged over a number of equipments. "Life" figures based on such concepts are of little interest to military people, since they bear no fixed relation to the factor that is all important; which might be called the "guaranteed life." This figure would represent the period during which *none* of the equipments would fail, and absolute reliability could be assumed. (Since failure is a statistical phenomenon, absolute guarantee might not be possible, but military needs might require that

failures in this period be of the order of one percent or less, depending on the application.) Even though this "guaranteed life" were quite short, equipment could be serviced or replaced as required, with virtual freedom from unexpected failures.

1.4 EASE OF PRODUCTION

While it may appear that cost is of no importance in military apparatus, this is far from true. While money may be appropriated freely, in the final analysis neither materials nor manpower are inexhaustible and methods adapted to simple rapid production are frequently a major requirement. For example, without this approach the wholesale expenditure of complete transmitter-receiver units could not have been contemplated, and the proximity fuze would have remained a laboratory toy.

Startling progress has been made in this field, particularly in the development of methods to reduce the labor of assembling and wiring. Circuits are stamped, painted, printed, sprayed, or molded, combining in one operation that which would otherwise require many steps. In addition, these methods are well adapted to miniaturization and unitized construction. It seems certain that vigorous experimentation

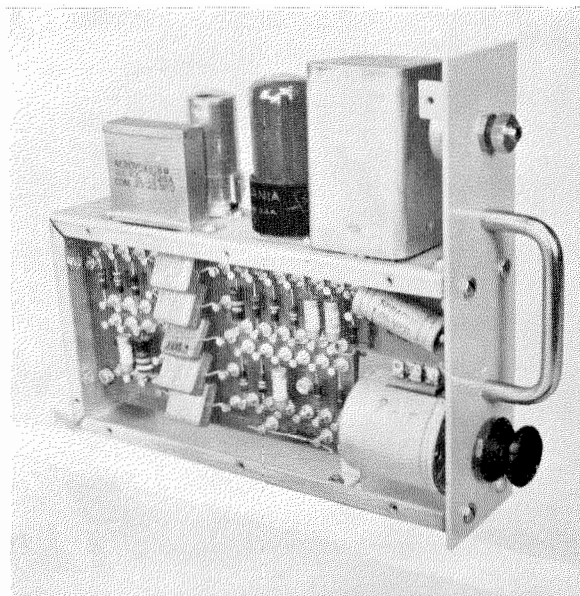

Unitized modulator unit of the plug-in type of construction as used in the FTL-10-A 23-channel multiplex radio link.

along these lines will bring startling changes in both military and commercial apparatus in the next few years.

1.5 OTHER TRENDS

Several additional trends may be noted. Except where power output is needed, there is no real need for the high plate voltages customarily used. Steps to reduce operating voltages frequently simplify problems of power supply and heat dissipation.

Increasingly severe requirements in ambient conditions are being imposed by military needs. For use in the arctic, equipment should survive storage at -85 degrees centigrade for long periods and be operable at -65 degrees centigrade. In some new jet aircraft, the most desirable position for the installation of radio gear would subject it to temperatures approaching 200 degrees centigrade. Until these conditions can be met without sacrifice of performance or reliability, we cannot say we have finished our job.

Increased simplicity of operation, with automatic control over all possible points of mis-

adjustment, will make it possible for personnel untrained in electronics to use new apparatus with ease and certainty.

In an endeavor to decrease the total number of units required in a given installation, an effort is being made to increase the frequency coverage of single transmitter and receiver units. Greater precision of channel selection will permit narrower channels, but this must be obtained without increasing excessively the number of quartz crystals in the equipment.

2. Conclusion

Trends in the development of electronic equipment for military use show that every designer should check his products for the application of the following principles: miniaturization, unitized construction, extreme reliability for certain "guaranteed life," and ease of production without waste of manpower or materials. When these needs have been satisfied as fully as the electronic art permits, he may be sure his design will fill the purpose for which it was intended with maximum utility.

Development of Single-Receiver Automatic Adcock Direction-Finders for Use in the Frequency Band 100-150 Megacycles per Second*

By R. F. CLEAVER

Standard Telephones and Cables, Limited, London, England

THE PAPER describes the development of automatic direction-finders primarily intended for measuring the bearings of aircraft, on signals radiated in the frequency band 100 to 150 megacycles per second. The basic system employs fixed elevated-H Adcock antennas and a single receiver, and, with the exception of the earliest model, all instruments give cathode-ray-oscillograph indication.

An examination of the advantages and limitations of fixed-antenna automatic direction-finders employing two or more receivers leads to an account of the reasons for the adoption of a single-receiver system in the present development. The principles and evolution of this system are explained with reference to the original experimental models, whose performance is discussed.

A naval direction-finder based on one of the experimental models is described in detail, and statistics are presented to show that the probable instrumental error varies from about 0.6 to 1.25 degrees over the frequency band, after compensation for octantal error. Bearings can be measured on signals of field strength down to 7 microvolts per metre or less.

The paper concludes with a description of direction-finders for use on land. One of these, under current development, will be capable of unattended operation on two alternative frequency-channels, with bearing indication and full remote-control at points up to 20 miles distant.

• • •

1. Introduction

The development described in this paper was originally undertaken in 1941 with the primary object of increasing the speed and reliability of

* Reprinted with minor additions from *Journal of the Institution of Electrical Engineers*, v. 94, Part IIIA, n. 15, pp. 783-799; 1947.

very-high-frequency direction-finding at aerodrome ground-stations. At that time it appeared likely that increasing traffic would shortly lead to saturation of the manual direction-finding system, which had served very well during the critical early years of the war. In the event, however, it proved impossible to develop and introduce the automatic system in time for the peak period of Royal Air Force activity, and with the completion of experimental models, the development might have been discontinued in the absence of a new incentive. This arose towards the end of 1942, in the form of a requirement of the British Admiralty for a new very-high-frequency direction-finder for use on aircraft carriers. Satisfactory tests with the second experimental instrument described later in this paper led to the adoption of a virtually identical circuit for the new naval direction-finder, now known in its production form as "Admiralty D/F Outfit FV5."

Since the end of the war it has become possible to resume the development of the system to meet specific ground-station requirements, notably unattended operation of the direction-finder with remote indication and control over many miles of land-line.

2. Choice of System

Some of the principles adopted in the developments described in this paper had not previously been applied to any great extent, and, before giving a detailed account of the work, it is necessary to examine the reasons underlying the choice of system.

For the antenna system, there was no practical alternative to the elevated-H Adcock arrangement, which is extremely convenient for wavelengths between 2 and 3 metres, and combines reasonable freedom from polarization error with adaptability for automatic indication of bearings

on a cathode-ray oscillograph. The ultimate use of oscillographic indication was regarded as essential for speed of operation and for automatic indication of the presence of a signal, though it was expedient to use a different form of indication on the first model.

Choice of method for automatic indication lay between the static and the continuously rotating antenna (or goniometer) systems. The former were preferred for their flexibility in speed of indication and adaptability to more satisfactory forms of bearing indication. There was also some reluctance to introduce continuously rotating machinery if this could be avoided.

Automatic direction-finders of the "static" class are in general characterized by the fact that signals related in amplitude by a tangent law are derived from two orthogonal antenna combinations, amplified with or without frequency conversion, and applied to a cathode-ray tube to produce corresponding orthogonal deflections of the electron beam. The resultant deflection can then be arranged to indicate the direction of arrival of the signal. The voltage amplification required may be up to the order of 10^8 times, and no difference in amplification of the signal components can exceed 2 per cent if the maximum quadrantal error is to be kept below 0.5 degree. Signals from the two directional antenna combinations can only give the line of the required bearing; to obtain its sense, the phases of the signals from the directional antenna combinations must be compared with that of a signal from a central omni-directional antenna. The latter signal requires corresponding amplification, without change of relative phase.

In general, the signals may be amplified in two ways; either in separate balanced amplifiers or, if previously identified by modulation, in a common amplifier with subsequent separation before application to the deflecting elements of the oscillograph. The following considerations led to the choice of the second alternative for the direction-finders described in this paper. The two systems are here distinguished as "balanced-receiver" and "single-receiver" systems.

2.1 BALANCED-RECEIVER SYSTEMS

Automatic direction-finders employing balanced receivers were first constructed by Watson

Watt and Herd more than 20 years ago for research into the nature and origin of atmospherics,¹ and have since been widely used, particularly for high-frequency work. Details of some of the earlier instruments have been published^{2,3} but at the time of writing (November, 1946) information on modern equipments of this type is lacking. The following discussion is therefore based on general principles, without reference to specific developments. The relative importance of the advantages and disadvantages depends greatly on the frequency band for which the direction-finder is designed.

Advantages

- A. Basic simplicity of conception.
- B. Possibility of obtaining a bearing on one transmission in the presence of interfering radiation.
- C. Possibility of assessing the reliability of bearing indications from the character of the oscillograph display.

Disadvantages

- A. Necessity for a high degree of balance between the receivers in respect of gain, phase shift and bandwidth. This involves the use of special receivers with provision for stage-by-stage equalization between them. Manual gain-controls must be ganged and provided with matching adjustments. Automatic gain-control necessarily involves considerable difficulty and is not used in instruments that have been described in the literature.
- B. Necessity for frequent checking of the equalizing adjustments, whose unavoidable variations lead to quadrantal error and ellipticity of indication.
- C. Limitation in the improvement in signal-to-noise ratio which can be gained by the use of selective circuits, governed by considerations of frequency stability and consequent difficulty in maintaining the necessary phase and amplitude balance.
- D. Directional accuracy is impaired by any inequality between transmission lines connecting the antennas and receivers, and by any stray pick-up on them. Difficulties in these respects increase with frequency.
- E. The form of bearing display obtained is not suitable for remote presentation, nor is the equipment itself suitable for unattended operation.

¹ R. A. W. Watt, and J. F. Herd, "An Instantaneous Direct-reading Radio Goniometer," *Journal of the Institution of Electrical Engineers*, v. 64, p. 611; 1926.

² R. A. W. Watt, J. F. Herd, and L. H. Bainbridge-Bell, "Applications of the Cathode-Ray Oscillograph in Radio Research," 1st Edition, His Majesty's Stationery Office, London, 1933; pp. 123-242.

³ Staff of the Radio Research Station, "A Short-Wave Cathode-Ray Direction Finding Receiver," *Wireless Engineer*, v. 15, p. 432; 1938.

The first three disadvantages are fundamental and peculiar to balanced-receiver systems, while the other two may apply also to single-receiver systems, to an extent depending on their design.

2.2 SINGLE-RECEIVER SYSTEMS

All the direction-finders described in this paper are based on the single-receiver principle, and are thus free from the fundamental disadvantages of the earlier system. The fact that they lack the special qualities listed as advantages of the balanced-receiver system is insignificant for the purposes of the present development, as will be clear from the following considerations.

First, the theoretical simplicity of the balanced-receiver principle is largely illusory owing to the formidable number of adjustments which are necessary to make the system work, and the frequency with which they must be checked. On the other hand, if one accepts the initial complication of modulation and demodulation involved in the single-receiver system, the circuits required can be made very stable and do not require continuous adjustment. A normal communication receiver with automatic gain-control may be employed in the common channel.

Secondly, the inability of the single-receiver system to indicate correct bearings in the presence of an interfering signal is harmless so long as the interference is discontinuous and of short duration, and so long as its presence can be detected. These conditions are invariably satisfied in the very-high-frequency aeronautical band. Significant interfering signals are revealed either by their modulation, by an audible heterodyne note, by an abrupt change in bearing indication during the observation, by the presence of a bearing indication preceding or following the wanted transmission, or by any combination of these effects. Under bad conditions, a bearing indicator with a high speed of response gives the required information in short intervals between interfering signals.

Finally, the fact that a single-receiver instrument under automatic gain-control may not give an indication of propagation conditions likely to lead to serious error is only of importance under the sort of conditions liable to be encountered at frequencies below, say, 50 megacycles per second, and it is of little consequence in direction-finding on very-high-frequency sig-

nals from aircraft. At all material times these signals contain a substantial vertically polarized component and have a large angle of incidence. In general, conditions capable of giving bad polarization errors are only to be expected when the aircraft has a high angle of elevation, and when this is the case its speed and proximity will generally preclude accurate direction-finding in any case.

2.2.1 Identification of Signal Components in Single-Receiver Systems

Various modulation schemes have been suggested for signal-component identification. In the 3-tone system described by C. F. A. Wagstaffe,⁴ the signals from the two directional elements and the omni-directional element of the antenna system are modulated at different audio-frequencies. After amplification and detection, the 3 audio-frequency components are separated by filtering, and those corresponding to the directional elements have their frequencies changed to that of the third. The 3 components of common frequency are used to produce a bearing display similar in some respects to that of a balanced-receiver system. Although free from the fundamental disadvantages of the latter, the 3-tone system as described has certain shortcomings and, in particular, the use of 3 modulation-frequencies is a complication which can be avoided.

All the direction-finders described in this paper make use of the 2-tone system due to C. W. Earp,⁵ in which balanced modulation at different frequencies is applied to the signals from the 2 directional-antenna elements only. This results in suppression of the carrier which is later restored in constant phase by the addition of a signal derived from the omni-directional antenna, the combined signal then passing to the common receiver. The use of balanced modulators renders the carrier level substantially independent of azimuth, and so permits a greater average depth of modulation. The output from the receiver includes 2 audio-frequency components, whose relative amplitudes depend on the line of bearing of the received signal and whose line phases, relative to those of the original modulating tones, depend on its sense.

⁴ British Patent No. 496239.

⁵ British Patent No. 490940.

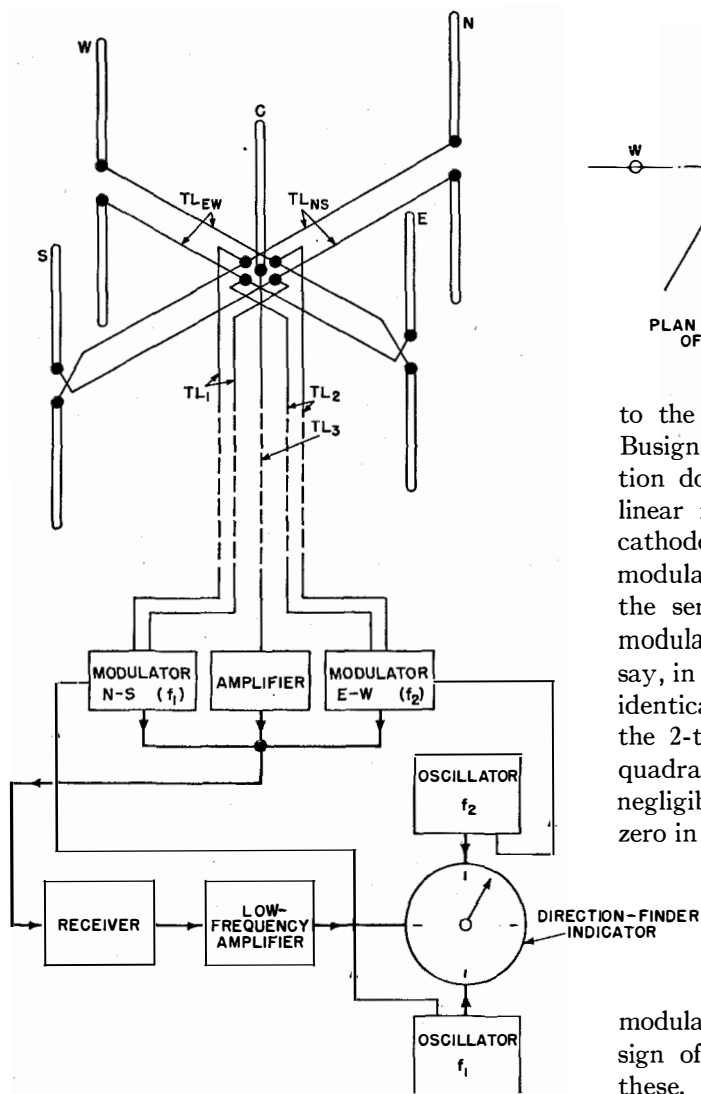
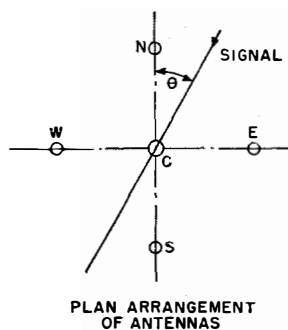

Fig. 1—First experimental model—block circuit diagram.

Two methods of indicating the bearing are described in the original patent, one employing a cathode-ray oscillograph and the other an electro-dynamometer type of instrument. More recently, an improved form of oscillograph display has been developed and is now used exclusively on the direction-finders here described.

A variant of the 2-tone system uses quadrature components of a single tone for balanced modulation of the directional signals. The phase of the receiver output at modulation frequency is then a linear function of the direction of arrival of the signal, which can therefore be determined by phase comparison with the modulating tone.



The process is electrically analogous to continuous rotation of a loop antenna, dipole pair or goniometer search-coil, and thus yields an instrument related to the automatic direction-finders⁶ proposed by Brailard and Goldschmidt,⁷ Marique,⁸ and others, and to the large class of instruments developed by Busignies.^{9,10} The use of quadrature modulation does not greatly simplify the circuit if a linear radial bearing display is required on a cathode-ray oscillograph, and moreover, if the modulation frequency is high, the method has the serious disadvantage that a change in the modulation envelope phase-shift by an angle α , say, in the receiver or display circuits causes an identical constant error in all bearings. With the 2-tone system the corresponding error is a quadrantal function of $(1 - \cos \alpha)$; it is quite negligible for small values of α and is in any case zero in the four cardinal directions.

3. Preliminary Experimental Work

Two experimental single-receiver direction-finders employing 2-tone modulation were constructed prior to the design of the prototype model. In the first of these, 3 separate transmission lines were employed between the antenna system and the modulators and amplifier in the direction-finder office, and the band-width which could be covered without antenna and line adjustments was very restricted. In the second model, this difficulty was overcome by transferring the modulators and amplifier to the masthead. At the same time, the method of indicating the bearing was improved by the substitution of a

⁶ R. Keen, "Wireless Direction Finding," 3rd Edition, Iliffe, London, 1938; pp. 688-700.

⁷ French Patent No. 516295.

⁸ J. Marique, "Un nouveau radiogoniomètre à lecture directe," *L'Onde Electrique*, v. 10, p. 355; 1931.

⁹ H. G. Busignies, "Un nouveau radio-compass," *L'Onde Electrique*, v. 9, p. 397; 1930.

¹⁰ H. G. Busignies, "The Automatic Radio Compass and its Application to Aerial Navigation," *Electrical Communication*, v. 15, pp. 157-172; October, 1936.

cathode-ray oscillograph for the original electro-mechanical indicator. The second model was used for much of the experimental field-work and many of the results quoted in Section 4.5 were obtained with it.

3.1 FIRST EXPERIMENTAL MODEL

This was designed to operate in the frequency band 100 to 125 megacycles per second, using a British Air Ministry receiver, Type R1132A.

3.1.1 Theory

This will be considered in some detail since the basic principles were preserved in all subsequent equipment, though the circuit technique was changed radically.

The form and inter-connection of the fixed Adcock antenna-array were conventional and will be apparent from the block circuit diagram and plan of the system, Fig. 1. The diagonal transmission lines TL_{NS} and TL_{EW} were made equal to a half-wavelength in the mid-band frequency (112 megacycles per second), and transmission lines TL₁, TL₂ and TL₃ were equalized electrically at the frequency of alignment. The modulators and amplifier were located in the direction-finder office and had a common output-circuit connected to the receiver.

When the antenna system is exposed to radiation of wavelength λ having a vertical electric field strength \mathcal{E}_V and an azimuthal direction of arrival θ , it can be shown by the aid of well-known theory that the voltages applied to the amplifier and the N-S and E-W modulators are respectively of the form

$$e_C = k_C \mathcal{E}_V \sin(\omega t - \alpha_3) \tag{1}$$

$$e_{NS} = k_{NS} \mathcal{E}_V \sin(2\pi d \cos \theta / \lambda) \times \sin(\omega t + \frac{1}{2}\pi - \beta_{NS} - \alpha_1) \tag{2}$$

$$e_{EW} = k_{EW} \mathcal{E}_V \sin(2\pi d \sin \theta / \lambda) \times \sin(\omega t + \frac{1}{2}\pi - \beta_{EW} - \alpha_2), \tag{3}$$

where k_C , k_{NS} and k_{EW} are constants of the system, α_1 , α_2 , α_3 , β_{NS} and β_{EW} are the phase shifts in transmission lines of corresponding suffix and $2d$ is the diagonal of the antenna system.

If

$$\alpha_1 = \alpha_2 = \alpha_3 = \alpha, \quad \beta_{NS} = \beta_{EW} = \frac{1}{2}\pi$$

and

$$k_{NS} 2\pi d / \lambda = k_{EW} 2\pi d / \lambda = k,$$

and if

$$2\pi d / \lambda \gg 1 \text{ (say),}$$

the expressions for the input voltages reduce to

$$e_C = k_C \mathcal{E}_V \sin(\omega t - \alpha) \tag{4}$$

$$e_{NS} \simeq k \mathcal{E}_V \cos \theta \sin(\omega t - \alpha) \tag{5}$$

$$e_{EW} \simeq k \mathcal{E}_V \sin \theta \sin(\omega t - \alpha). \tag{6}$$

The sign of approximation in (5) and (6) indicates that octantal spacing-error is being ignored; for exact equality, $2\pi d / \lambda$ would have to be indefinitely small.

The signals (5) and (6) are modulated at frequencies f_1 and f_2 with suppression of carrier, and the signal (4) is amplified, all the outputs being combined in the common circuit to yield a signal of the form

$$e \simeq k'_C \mathcal{E}_V \sin(\omega t - \alpha) [1 + (k'/k'_C) \times (\cos \theta \sin 2\pi f_1 t + \sin \theta \sin 2\pi f_2 t)], \tag{7}$$

where k'_C and k' are new constants including the gains of the amplifier and modulators respectively, those of the latter being assumed to be equal. Phase shifts in the modulators and amplifier are assumed equal and omitted from (7) to avoid complication.

Expression (7) represents the modulated signal applied to the receiver. The relative gains of the modulators and amplifier are assumed to be regulated to ensure that the maximum instantaneous modulation depth $k' \sqrt{2/k'_C}$ (which is obtained for bearing angles making $\cos \theta = \pm \sin \theta$) is less than the maximum modulation depth that can be handled by the receiver. In a typical case, allowing for a factor of safety, k'/k_C would not be allowed to exceed 0.5.

The output from the receiver contains components of current at the modulation frequencies f_1 and f_2 which are of the form

$$i \simeq K f(\mathcal{E}_V) [\cos \theta \sin(2\pi f_1 t - \psi_1) + \sin \theta \sin(2\pi f_2 t - \psi_2)], \tag{8}$$

where K is a new constant including the gain of the receiver and the load impedance, $f(\mathcal{E}_V)$ depends on the law of the detector and ψ_1 , ψ_2 represent the modulation-frequency envelope phase-shifts through the receiver, and phase-shifts in the low-frequency circuits.

The current i passes through the signal coil of the bearing indicator whose field coils N-S and E-W are supplied with constant current i_1 and i_2 , derived from the modulating oscillators, and adjusted to be in phase with the corresponding components of the signal current. The instrument has a freely rotatable element carrying a pointer indicating on a 360-degree scale. If ϕ is the pointer reading, the law of the instrument is such that synphased currents in the signal coil and the N-S field-coil exert a torque on the moving element approximately proportional to their product and to $\sin \phi$. Similarly, synphased currents in the signal coil and the E-W field-coil exert a corresponding torque proportional to $-\cos \phi$.

Influenced by currents i , i_1 and i_2 , the moving element is acted upon by two torques varying at the modulation frequencies and takes up a mean angular position ϕ in which the average value of the sum of the torques is zero. This position is defined by

$$\text{av. value of } (i \cdot i_1 \sin \phi) - \text{av. value of } (i \cdot i_2 \cos \phi) = 0. \quad (9)$$

Thus for the mean position

$$\cos \theta \sin \phi - \sin \theta \cos \phi \approx 0 \quad (10)$$

or

$$\phi \approx 0.$$

The mean position of the pointer therefore indicates the bearing of the incoming signal, and as the rotatable element is in general acted upon by torques varying at different frequencies, it vibrates at a frequency equal to their difference with an amplitude which depends on the strength of signal. This vibration is limited to the order of ± 1 degree or less by inertia, friction and eddy-current damping.

Components of the receiver output-signal at frequencies other than f_1 and f_2 , including noise voltages, can only produce oscillatory or transient movements of the indicator. These movements are small unless the signal components at f_1 and f_2 are very weak, corresponding with conditions close to maximum range.

3.1.2 Practical Details

The four dipoles were resonant at 112 megacycles per second and their diagonal spacing, 76 centimetres, caused a maximum octantal

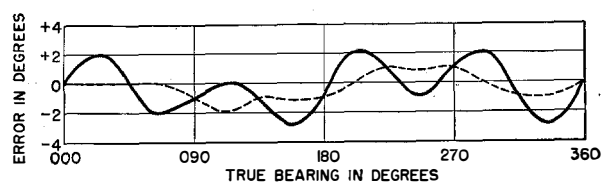

Fig. 2—First experimental model—instrumental error. Full line—uncorrected. Broken line—corrected for 2-degree (maximum) octantal error.

error of 2 degrees at the same frequency. The antenna structure was carried on a 25-foot steel tubular mast, rotatable through 360 degrees to allow investigation of instrumental error on a single incoming signal.

Transmission lines TL_{NS} and TL_{EW} were made from twin circular mineral-insulated copper-clad cable having a characteristic impedance of about 70 ohms and TL_1 , TL_2 were each made from two lengths of the same material parallel at both ends. TL_3 was a coaxial cable of similar construction. Interchangeable link sections at the receiving end were used to adjust the electrical lengths of these lines.

The lines were coupled inductively to the amplifier and modulators, which comprised respectively a single CV1091 (EF50) high-frequency pentode, and two pairs of valves of the same type in push-pull input, parallel output connection. The five valves worked into a common output circuit connected over a short line to the receiver. Modulating voltages at 45 cycles per second (f_1) and 60 cycles per second (f_2) were applied to the suppressor grids, and differential cathode bias-control on the modulators provided overall compensation for quadrantal error.

3.1.3 Performance

The instrumental accuracy was measured on a local radiated signal by observing the "tracking" accuracy of the bearing indicator as the antenna system was rotated through 360 degrees in small steps, using a signal radiated by a field oscillator some 50 to 100 feet from the direction-finder antennas. This method was also used on subsequent models. A typical instrumental error curve is shown in Fig. 2.

With physically equal antenna lengths and optimum adjustments to lines and modulators, the maximum error at the frequency of align-

ment was nearly 2 degrees after compensation for octantal error. Quadrantal error increased to some 2 degrees (maximum) for frequency changes of ± 3 megacycles per second, giving a maximum error of about 4 degrees at the least favourable frequency and azimuth in any sub-band about 6 megacycles per second wide between 100 and 125 megacycles per second.

The sensitivity was measured in terms of the minimum field strength required to give a first-class bearing indication, which was somewhat arbitrarily defined as one in which random noise

caused a pointer fluctuation of ± 5 degrees or less. At mid-band, the field strength required was about 6 microvolts per metre, with the modulator gains adjusted to give an instantaneous maximum modulation depth of 60 per cent.

3.1.4 Limitations

A. *Frequency Coverage*.—For frequencies differing from that of alignment by more than 3 megacycles per second, mis-phasing between sideband and carrier components of the signal caused increasing quadrantal error, loss of sensitivity and in extreme cases, sense reversal.

B. *Presentation of Bearings*.—Friction and mechanical unbalance affected the accuracy of bearing indication on weak signals, and inertia and damping limited the speed of response. There was no effective indication of the strength or absence of a signal.

C. *Speech Reception*.—Low modulation-frequencies were dictated by the design of the bearing indicator and resulted in poor intelligibility of speech reproduction during direction-finder operation.

3.2 SECOND EXPERIMENTAL MODEL

The above limitations were largely overcome in a second model whose circuit was later adopted with little alteration for the Admiralty D/F Outfit FV5 described below. The block schematic diagram (Fig. 3) applies equally to both.

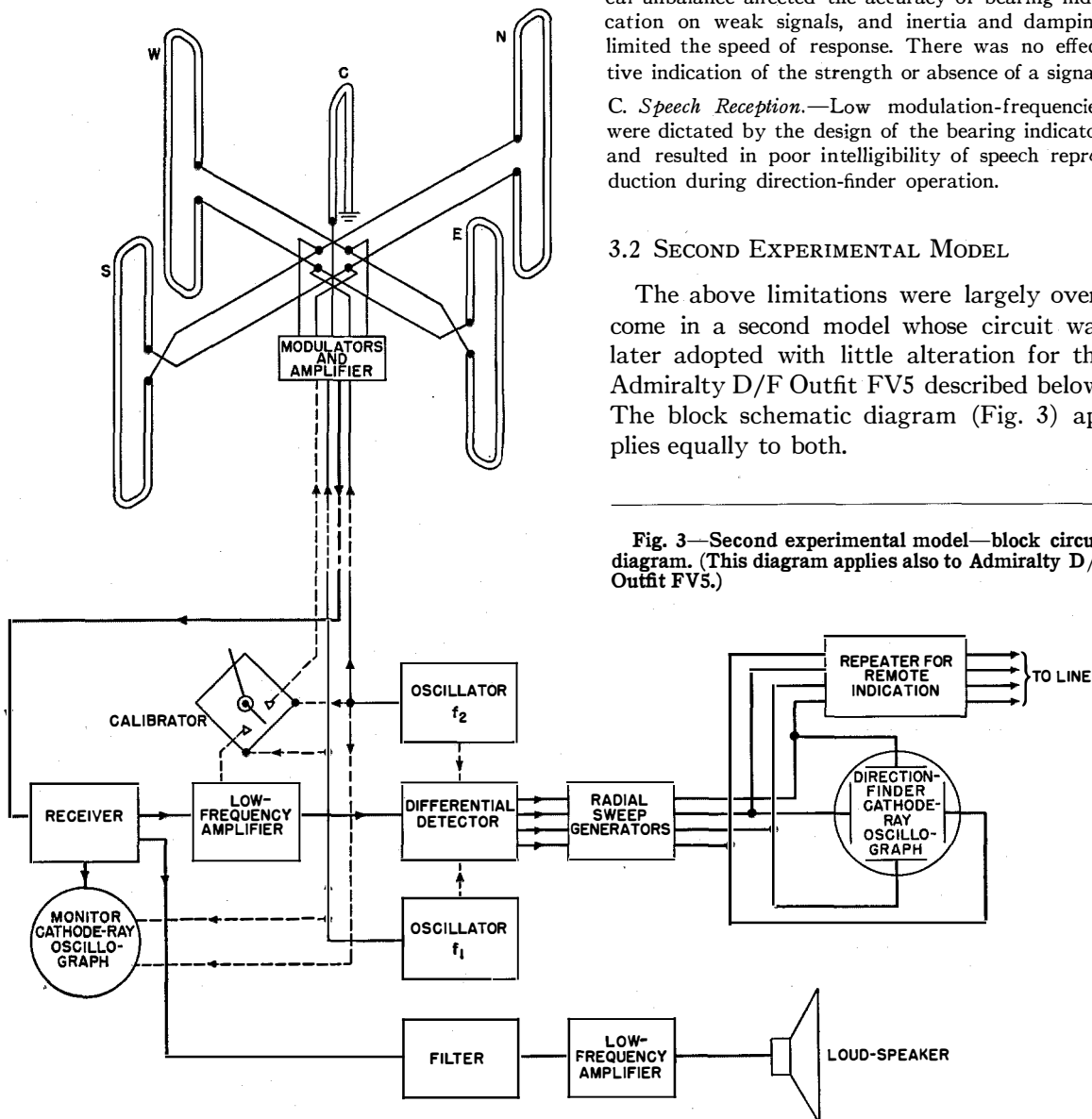

Fig. 3—Second experimental model—block circuit diagram. (This diagram applies also to Admiralty D/F Outfit FV5.)

3.2.1 Improvements in Technique

A. *Frequency Coverage.*—Folded antennas were adopted with direct connection to the amplifier and modulators, which were transferred to the mast-head. This change was made possible by the use of CV53 (Standard Telephones and Cables type S26A) grounded-grid triodes working first to a band-pass output circuit, connected over a single coaxial line to the receiver below. A useful increase in accuracy resulted from the improved shielding given by the grounded-grid arrangement.

B. *Presentation of Bearings.*—To obtain cathode-ray-oscillograph indication, the modulation-frequency components of receiver output [expression (8), above] had first to be converted to a common frequency in separate channels, and then filtered to remove unwanted signal components and improve signal-to-noise ratio. The common frequency finally chosen was zero, the conversion being effected in differential detectors working into resistance-capacitance filters of adjustable time-constant. Although this arrangement is exceedingly convenient from the point of view of the designer, bearing indication by the steady displacement of the oscillograph beam was found to be psychologically unsatisfactory; some form of radial sweep appeared to be necessary. Some improvement was obtained at first by modulating the deflection sensitivity of the oscillograph, but this arrangement was later abandoned in favour of an electronic switching circuit¹¹ whereby the "spot" indication was converted to a full radial trace.

C. *Speech Reception.*—If the modulation frequencies and the difference between them were made high enough to eliminate all audible interference, large and very unequal modulation-envelope phase-shifts would occur in the receiver. This would have been undesirable for high stability of phase adjustment, and a satisfactory compromise was found in the use of 5 kilocycles per second for f_1 and 6 kilocycles per second for f_2 , with a sharp band-elimination filter in the speech circuit, centred on the difference frequency, 1 kilocycle per second, and a low-pass filter with cut-off at about 3 kilocycles per second to eliminate modulation-frequency components. The filters scarcely affected the intelligibility of speech.

¹¹ British Patent No. 590260.

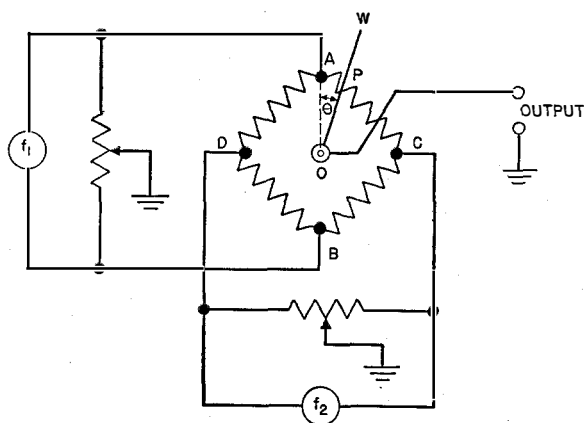

Fig. 4—Calibrator circuit.

3.2.2 Monitoring and Testing

As in the first model, the antennas were mounted on a mast, which could be rotated through 360 degrees for the measurement of instrumental error. A further check on the behaviour of the antenna system was obtained by the inclusion of a small monitor oscillograph (CV967) to indicate the modulation depth and permit estimation of the relative phase angles between carrier and sideband-resultants.

For checking the display circuits, a device was incorporated to simulate the modulation-frequency components of receiver output corresponding to any bearing θ . It utilized a simple geometrical property of the square which does not appear to be generally known and has been found to have a number of other useful applications.

The arrangement is illustrated in Fig. 4. Equal balanced-to-ground voltages at frequencies f_1 and f_2 are applied to the diagonally opposite points A, B, and C, D of a closed network of four equal, straight, uniform resistance elements arranged physically in the form of a square and resembling a Wheatstone bridge in which the battery and galvanometer are replaced by the sources of voltage at the two modulation-frequencies. A straight wiping contact arm OW is pivoted at O, the centre of the square, and by rotation in its plane can make contact at any point P on the network. If angle AOP, the angular position of the arm, is denoted by θ it can readily be shown that the point of contact P divides the element AC of the network so that $AP/PC = \tan \theta$. Thus the voltage picked up by the contact arm contains components at frequencies f_2 and f_1 in the ratio $(\tan \theta)$, and is therefore equivalent to the receiver output corresponding with a signal from a direction θ . Symmetrical deformation of the resistance network can be made to simulate various types of periodic error. For example, a circular network gives an octantal error of maximum value 4 degrees, of sign opposite to that of the octantal spacing error in an Adcock antenna system.

It may be noted that the device provides a facility similar to that of the angular calibrator of Watson Watt, Herd and Bainbridge-Bell,¹² though in the present equipment it is not used to

¹² Reference 2, p. 162.

calibrate the oscillograph. Although generally referred to as a "calibrator," it was usually employed for preliminary adjustments and functional tests on the display circuits. By switching off the antenna modulators and using the calibrator output to modulate any carrier wave at the grid of the central antenna amplifier the functional test could be extended to cover the receiver.

3.2.3 Mechanical Construction

The direction-finder office equipment was rack-mounted and with the exception of the cathode-ray-oscillograph units was accommodated on one 19-inch rack, 6 feet high. In later developments, the need for front accessibility and exceptionally rugged construction led to a considerable increase in size.

3.2.4 Performance

In performance, the second instrument resembled production models described in detail later. The improvement over the first model is indicated by an increase in working bandwidth by a factor of about four, the band 100 to 125 megacycles per second being covered without adjustment to antennas or lines. Later tests showed that the band could be increased to 100 to 150 megacycles per second before serious difficulties with sideband phasing were encountered. For a much greater extension it is probable that folded dipoles would have to be abandoned.

For practical purposes, the sensitivities of the two experimental models were similar, though the use of different methods of bearing indication prevented direct quantitative comparison.

4. British Admiralty D/F Outfit FV5

This direction-finder was developed for use on aircraft carriers and covered the frequency band 100 to 150 megacycles per second. The circuit is essentially the same as that of the second experimental model (Fig. 3) except that a single output circuit with remote tuning-control was used in the antenna system. A prototype known as "Admiralty D/F Outfit FV5X" was made in small numbers and covered the band 115 to 145

megacycles per second with a band-pass output circuit. In other respects it resembled the production equipment.

4.1 ANTENNA SYSTEM

The construction of the antenna system is shown in the photographs, Figs. 5 and 6, and the circuit in schematic form in Fig. 7.

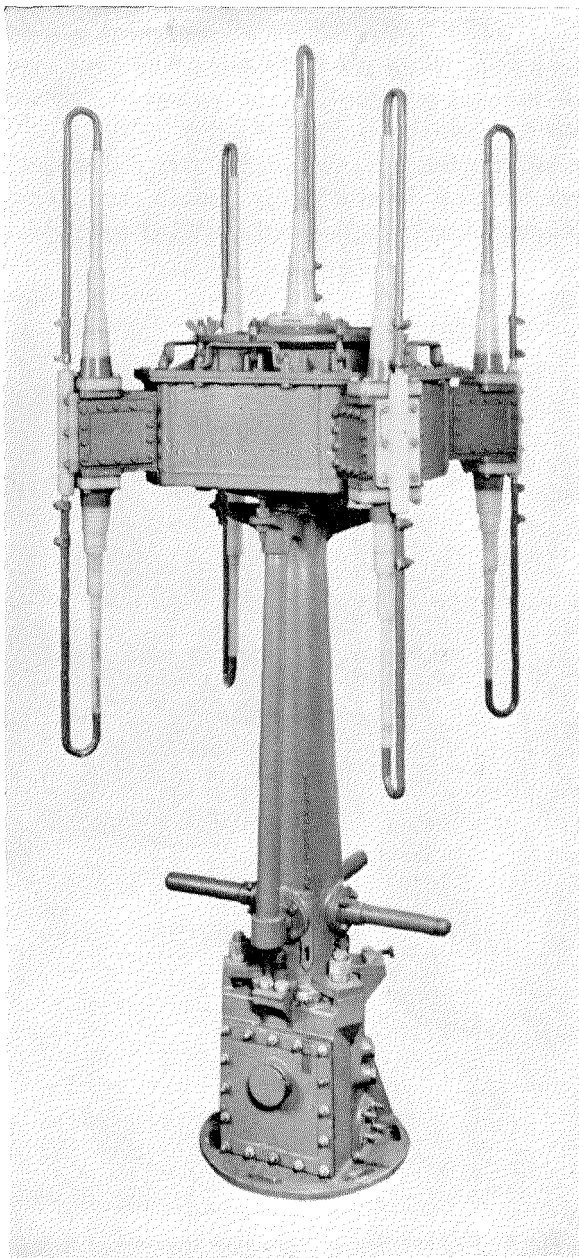

Fig. 5—FV5 antenna system.

4.1.1 Mechanical Construction

Polythene-covered folded-dipole antennas are mounted on short stubs projecting from the corners of a cast aluminium-alloy box whose hinged lid carries the central folded monopole. The box is supported by a short tubular column mounted on a junction box and capable of limited rotation for test purposes. The whole assembly is water-tight and is normally bolted to the top of a steel lattice mast, hinged at its base, which is carried on a sponson at a level somewhat below the flight-deck. The mast may be lowered outboard into a horizontal position when the direction-finder is not in use.

Within the box, the air-dielectric "diagonal" transmission lines actually run in cast metal shields of rectangular section fixed along the

inner sides. Plug-in modulators and central amplifier facilitate valve changing; their arrangement can be seen in Fig. 6. The box also contains the common output circuit and a mains transformer for valve heaters. The total weight of the water-tight antenna assembly as illustrated in Fig. 5 is 160 pounds.

Diagonal spacing of antennas is 76 centimetres, giving maximum octantal errors of 1.6 degrees at 100 megacycles per second and 3.8 degrees at 150 megacycles per second, normally included in the site error calibration. When the direction-finder is used on land it is advantageous to use a cathode-ray-oscillograph scale compensated for octantal error. Such compensation is appropriate on instruments designed for direct-ray operation, when great accuracy is not required on high-angle signals.

4.1.2 Circuit

The conventional Adcock arrangement was retained (Fig. 7) but the use of folded antennas permitted direct connection to modulators and amplifier and so assisted in the maintenance of good sideband phasing and quadrantal balance over the frequency band. Within the band the folded antennas show a rather smaller variation in phase angle than plain antennas, and are therefore proportionately less critical as to length.

As in earlier models the diagonal transmission lines are designed to match the antennas (300 ohms) and to have a total electrical length of about half a wavelength at the mid-band frequency.

Resistive shunts are used to give the balanced

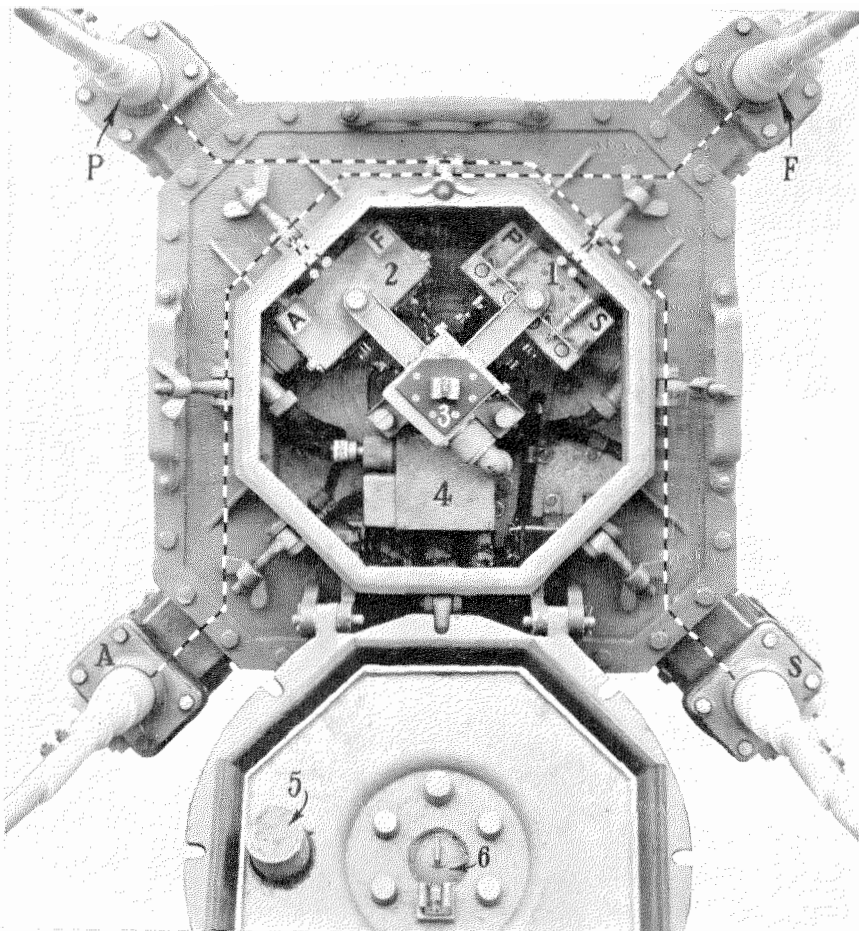

Fig. 6—FV5 antenna system—view from above with lid open. (1) Port-to-starboard modulator. (2) Fore-to-aft modulator. (3) Central amplifier. (4) Common output circuit. (5) Silica-gel desiccator. (6) Central antenna contact.

modulators an input impedance of about 150 ohms at mid-band, the valve input capacitances being annulled at this frequency by shunt inductances. Centre-taps on the latter are by-passed to ground to reduce "antenna effect" and connected to a differential cathode bias control in the direction-finder office for quadrantal balance adjustment. Modulation is applied at the control grids which are effectively grounded for signal-frequency currents by condensers integral with the valve housings.

The central antenna and its inverted amplifier are approximately matched by virtue of negative feedback so that no resistive loading is necessary in this case. The amplifier input capacitance is annulled at mid-band as in the case of the modulators, and provision is made for applying modulating voltage to the grid from the calibrator for test purposes (Section 3.2.2).

The output circuit, tuned by remote control from the direction-finder office, is common to all five valves and at the optimum tapping a single

coaxial line to the receiver is connected. Any slight stray signal picked up on this line merely changes the amplitude, or shifts the phase of the carrier component to a small extent, and therefore has little or no effect on the accuracy of direction-finding.

4.1.3 Factors Affecting Accuracy and Sensitivity

The accuracy of the antenna system depends on a number of factors of which the following are the most important:

A. Mechanical Construction.—The general use of machined castings for the structural work ensures adequate geometrical accuracy. With air-dielectric diagonal transmission lines the maximum reciprocal error which can be produced by (electrical) eccentric connection of the balanced modulators is x/d radians, where x and $2d$ are the eccentricity and antenna diagonal respectively, in the same units. For 0.5-degree maximum error, this requires that the eccentricity should be less than about 3 millimetres; the general accuracy of construction is such that adjustment of the point of connection during factory tests is not necessary.

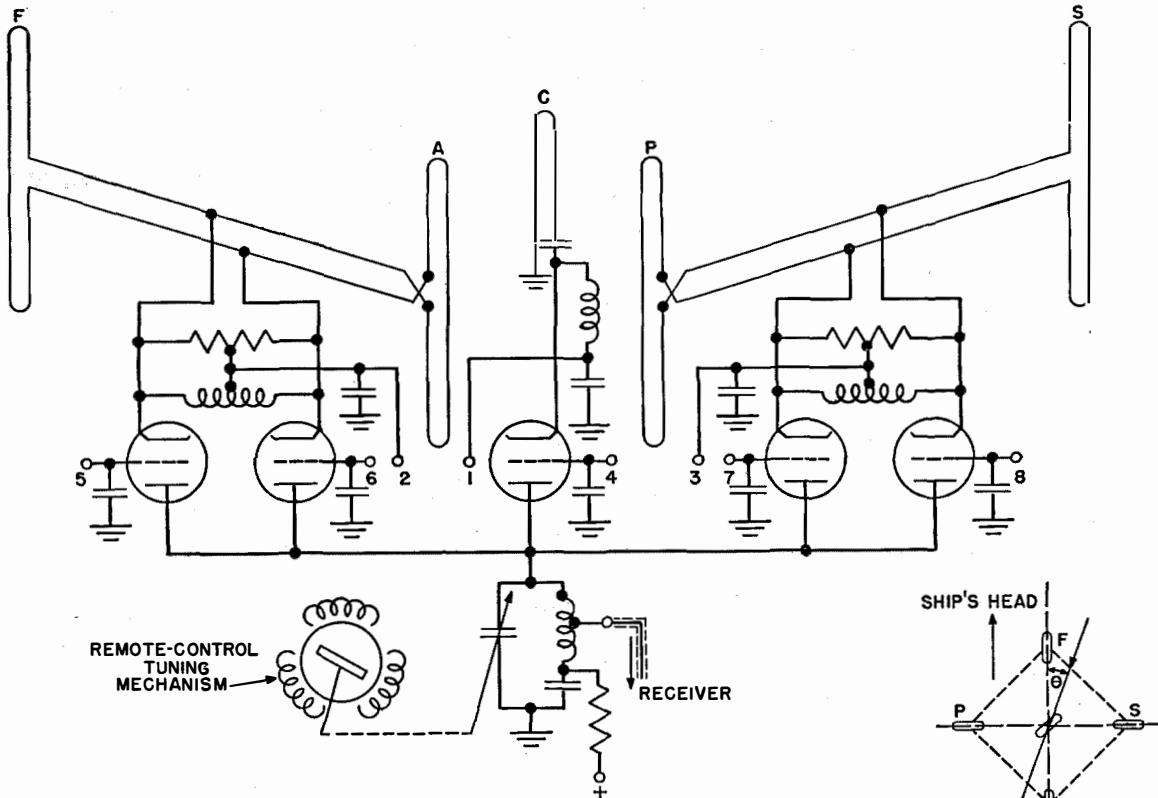

Fig. 7—Circuit of FV5 antenna system. Key to interconnection with direction-finder office equipment: (1) To fixed cathode resistance. (2, 3) To differential variable cathode resistances. (4) From ground (normal operation), or from calibrator (modulation test). (5, 6) From 5 kilocycle-per-second oscillator. (7, 8) From 6 kilocycle-per-second oscillator.

B. *Sideband-to-Carrier Phasing*.—This is kept as close as practicable over the frequency band in order to maintain sensitivity and minimize the effect on accuracy of unwanted modulation components such as might result, for example, from any residual carrier feedback into the modulators.

C. *Quadrantal Balance of Modulators*.—This is the only factor affecting accuracy that is under control in a working direction-finder of this type. It is adjusted by a method described in detail in Section 4.4.

D. *Modulation Depth*.—For good sensitivity and signal-to-noise ratio, and freedom from stray effects, the modulation depth should be as high as possible consistent with the avoidance of octantal error. In practice, a factor of safety must be allowed for variations in replacement valve characteristics.

4.2 DIRECTION-FINDER OFFICE EQUIPMENT

This is mounted in a rack combined with the operator's desk and is illustrated in Fig. 8. The receiver, control panel, bearing indicator and

monitor oscillographs are carried on the sloping panel immediately behind the desk, the remaining low-frequency circuits being mounted on hinged sections of the rack above. Power supply units are mounted below the desk.

4.2.1 Common Amplification Channel

This part of the circuit is conventional and comprises a superheterodyne receiver (Admiralty Type P47) having an intermediate-frequency band-width of 90 kilocycles per second (to 6 decibels down) followed by a low-frequency amplifier which drives the differential detectors.

The receiver has two stages of radio-frequency amplification and three stages of amplification at an intermediate frequency of 9.72 megacycles per second. The supersonic heterodyne is derived from a crystal oscillator with frequency multi-

plication by a factor of 18. For direction-finder operation, the receiver uses biased amplified automatic gain-control. At mid-band, the output signal-to-noise ratio is 20 decibels for an input signal of 3 microvolts modulated 30 per cent at 1000 cycles per second, in series with 100 ohms. The envelope phase-shift through the receiver at modulation frequencies (chiefly in the intermediate-frequency amplifier) is about 25 degrees.

The low-frequency amplifier includes two high-gain pentode stages (CV1935) under biased automatic gain-control developed from the output of the final push-pull stage (CV1052). The first stage is carefully shielded because stray pick-up at modulation frequencies cannot be

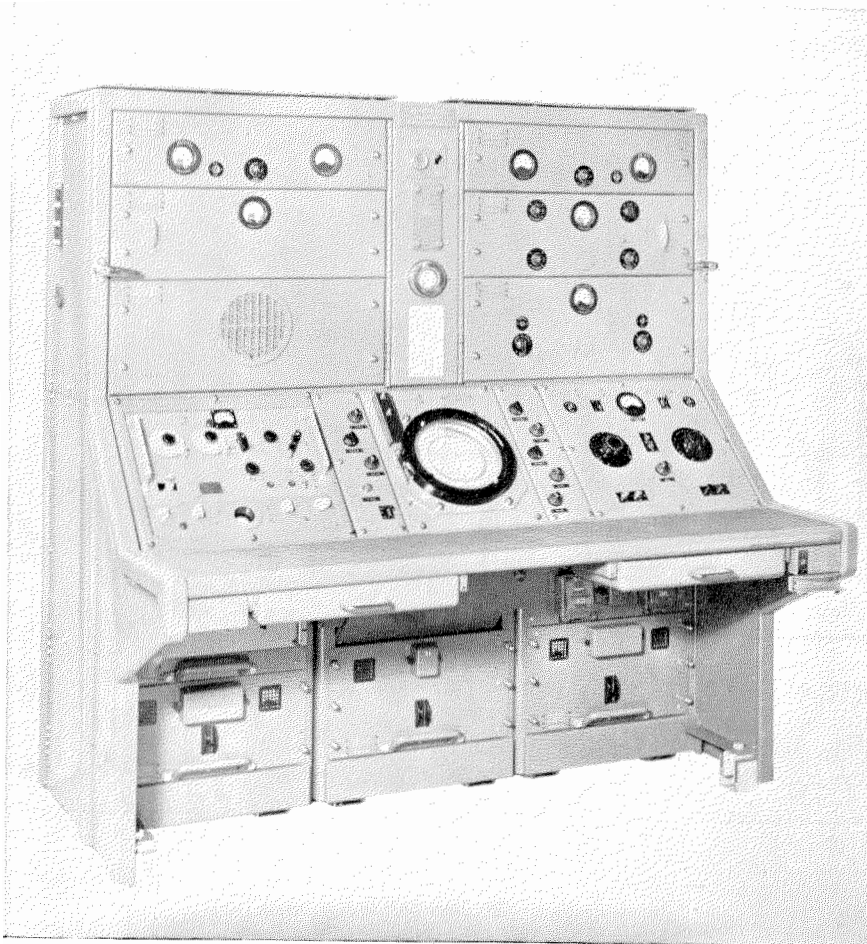

Fig. 8—Admiralty D/F Outfit FV5—main office equipment.

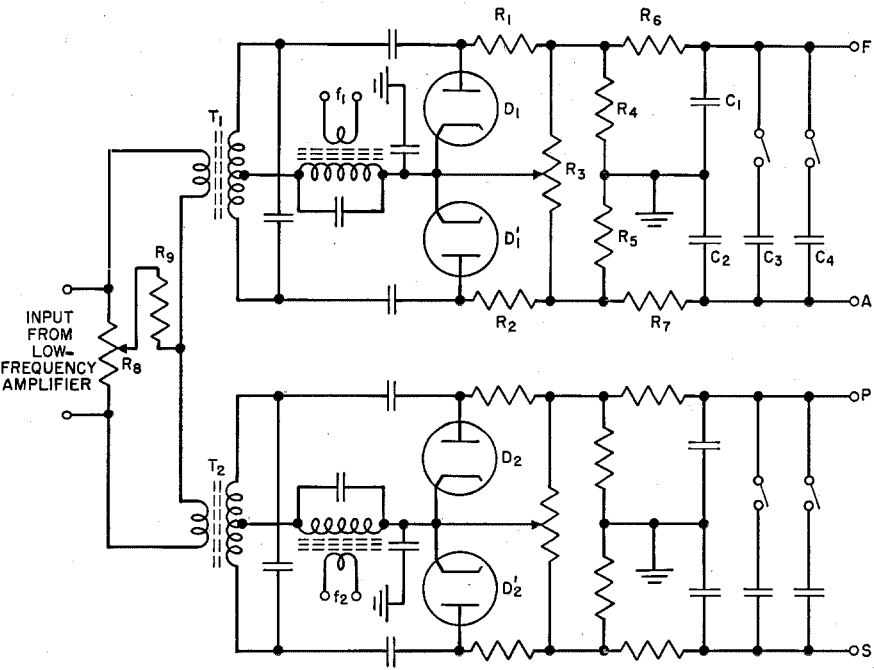

Fig. 9—Differential detector circuit.

reversal of the other. To ensure amplitude proportionality, the magnitude of each reference voltage must be at least half that of the corresponding push-pull input signal. Referring to the f_1 detector, Fig. 9, the potential divider R_4-R_5 determines the mean output potential with respect to ground while the adjustable potential divider $R_1R_3R_2$ is a cathode-ray oscillograph centering control which equalizes the F and A output potentials in the absence of signal. Each reference-voltage phase

is adjusted to give maximum cathode-ray oscillograph deflection in the appropriate direction, and the adjustment is stable within 1 degree over long periods. Misphasing causes only quadrantal error on weak signals, but an octantal component appears when the input signal becomes comparable in amplitude with the reference voltage.

4.2.2 Separation of the Orthogonal Deflection Components of the Signal

The low-frequency output from the common channel consists mainly of components at the modulation frequencies f_1 and f_2 (5 and 6 kilocycles per second). These are separated and converted to zero frequency in the differential detectors, illustrated in principle in Fig. 9. Input transformers T_1 , T_2 , tuned to f_1 and f_2 apply voltages which may be up to 200 volts (root mean square) to pairs of diode peak detectors, D_1D_1' and D_2D_2' respectively. Each pair of diodes is also supplied in parallel with a "reference voltage" or zero-beat heterodyne signal, derived from the corresponding modulating oscillator. The reference voltages are initially adjusted to be in line phase with the signal component of corresponding frequency. The direct-current output from each detector can be regarded as a zero-frequency voltage proportional to that component of the signal from which it is derived, and having a "phase" (polarity) which is determined by the phase of that component, in the sense that a reversal of one causes a

reversal of the other. To ensure amplitude proportionality, the magnitude of each reference voltage must be at least half that of the corresponding push-pull input signal. Referring to the f_1 detector, Fig. 9, the potential divider R_4-R_5 determines the mean output potential with respect to ground while the adjustable potential divider $R_1R_3R_2$ is a cathode-ray oscillograph centering control which equalizes the F and A output potentials in the absence of signal. Each reference-voltage phase

is adjusted to give maximum cathode-ray oscillograph deflection in the appropriate direction, and the adjustment is stable within 1 degree over long periods. Misphasing causes only quadrantal error on weak signals, but an octantal component appears when the input signal becomes comparable in amplitude with the reference voltage.

Initial quadrantal error due to unbalance between differential detectors and unequal deflection sensitivities in the cathode-ray oscillograph is compensated by the differential shunt resistance network R_3-R_9 . So far, we have only considered the action of the detector on input signals of the desired frequency. For all others, the differential voltages between the diode anodes alternate at the corresponding difference-frequency, and unless this is extremely low the effect on the output voltage is completely eliminated by the resistance-capacitance filter combination $R_6C_1C_2R_7$. This has a time-constant of about 0.03 second and allows adequate response to transmissions as short as 0.1 second. The speed of indication so obtained is high enough for all telephony-modulated transmissions and is generally used under conditions of interference. A shorter time-constant could be provided, if required for keyed transmissions.

Fig. 10—Converter circuit.

For most purposes a time-constant of about 0.3 second is preferred and is obtained by addition of the condenser C_3 . A time-constant of about 1 second is sometimes advantageous on extremely weak signals and is obtained by switching in condenser C_4 . The "slow" indication so obtained is not suitable for use when interference is likely.

The three speeds of indication—"fast," "medium" and "slow"—correspond to the use of filters of bandwidth (to 3 decibels down) 10, 1 and 0.3 cycles per second. Their effect on the ease and accuracy of reading when the signal is weak can be seen in Table 6, and in the photographs, Fig. 12.

4.2.3 Generation of the Radial Trace

The "converter" circuit, Fig. 10, is interposed between the differential detectors and the corresponding deflector plates of the cathode-ray oscillograph

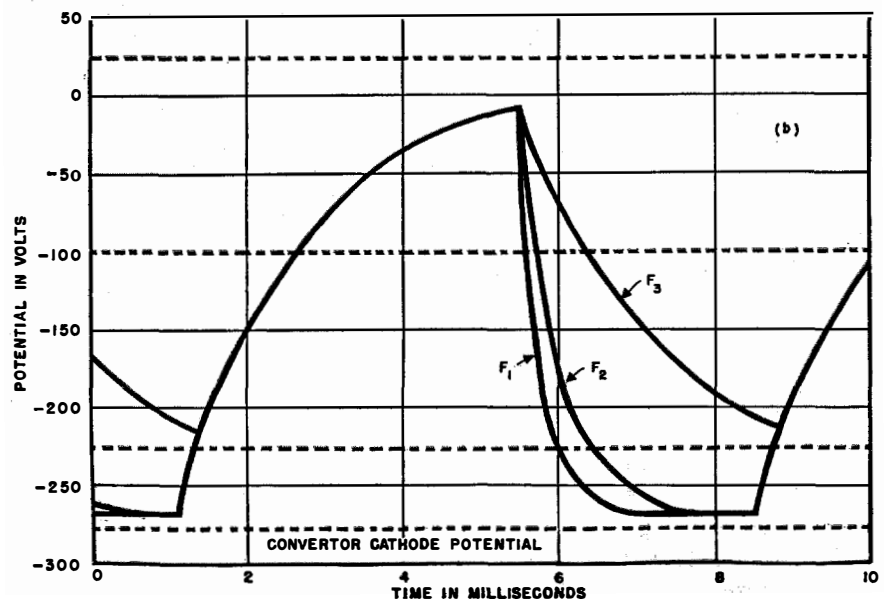
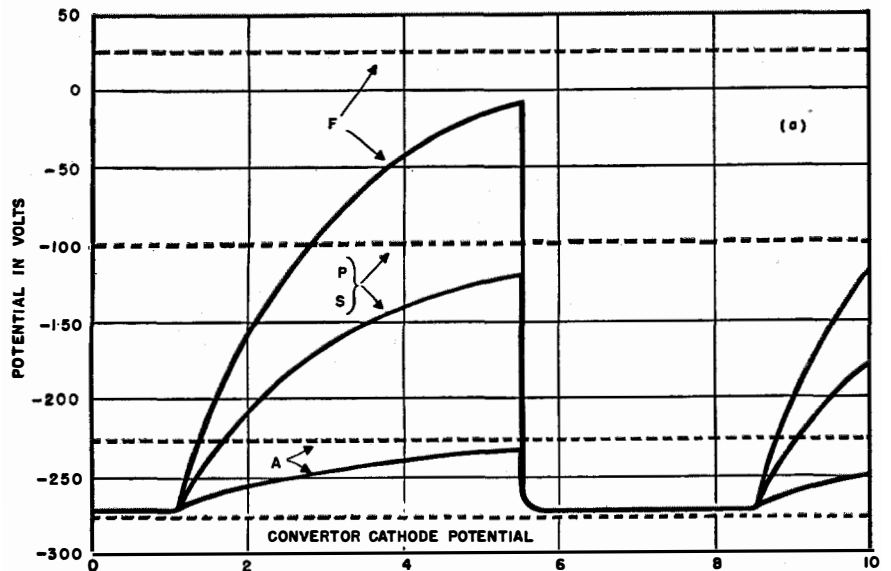
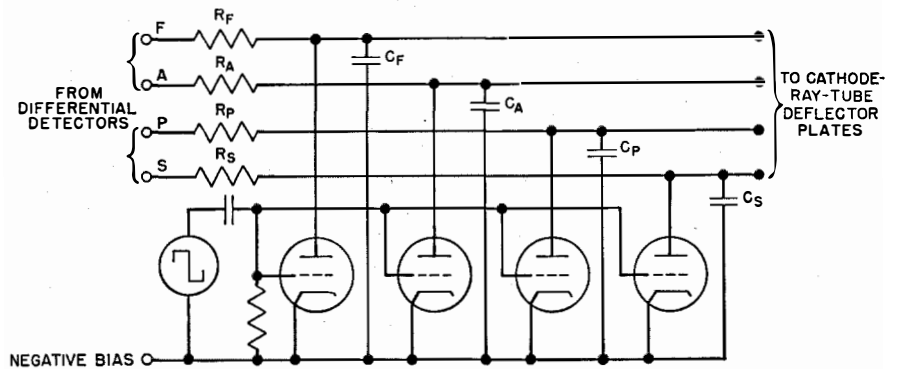

Fig. 11—(a) Converter input potentials and corresponding output waveforms for bearing 000 degrees. (b) Repeater output waveforms for various cable time-constants. The waveforms in (b) correspond with F in (a), and the following time-constants: F_1 —0.25 millisecond, F_2 —0.5 millisecond, F_3 —2.0 milliseconds.

to change the form of the deflecting potentials without affecting their relative amplitudes.

The deflector plates of the cathode-ray oscillograph are connected periodically (at about 135 cycles per second) to a common point by synchronous high-vacuum triode electronic switches controlled by a voltage of rectangular waveform. When the valves conduct, the condensers C_F , C_A , C_P and C_S associated with the F, A, P and S deflector plates of the cathode-ray oscillograph are discharged rapidly through relatively low resistances, and are charged relatively slowly through the high resistances R_F , R_A , R_P and R_S when the valves are cut off. The luminous spot on the cathode-ray-oscillograph screen generates the indicating trace by outward radial movement during the charging part of the cycle, and the discharge "fly-back" is so rapid as to be barely visible at normal brightness. The radial line is straight provided only that the charging time-constants $C_F R_F$, $C_A R_A$, $C_P R_P$ and $C_S R_S$ are all equal, a condition which is unaffected by valve characteristics. So long as the valves conduct sufficiently well to bring the trace close to the centre of the screen, their characteristics have no effect on the accuracy of bearing indication. Valve failure is indicated at once by the trace becoming "detached" from the centre of the screen. The charging time-constants are such as to permit the deflector plates to reach about 90 per cent of the steady input potential before discharge occurs.

The steady input potentials and the waveforms of the four output voltages from the converter circuit, corresponding to the indication of bearing 000 degrees are shown in Fig. 11(a). (The voltages applied to the port and starboard deflector plates are identical for this condition.) The relatively long period of quiescence in each cycle ensures the effective marking of the origin of the trace, and facilitates remote indication (Section 4.3).

4.2.4 Bearing Indicator

A 12-inch electrostatic cathode-ray tube (CV275) is used as the bearing indicator. Tubes of this type are individually calibrated and read bearings relative to ship's head on a 6-inch-diameter scale attached to the tube face. Bearings relative to true north are read on a separate annular scale of 8.5-inch diameter controlled by

the ship's master gyro-compass, using an angular cursor. At the working final anode potential of 1900 volts, the deflection sensitivity of the cathode-ray oscillograph is about 0.4 millimetre per volt for both pairs of plates, the difference being less than 5 per cent.

An auxiliary focusing control is used in an otherwise conventional circuit to bring the radial trace to sharpest focus at the outer extremity, giving it a slight taper. The control is obtained by adjusting the third anode to a potential close to that of the deflector plates at the end of the working (charge) stroke.

The brightness of the trace is sufficient for daylight observation without a viewing-hood; some idea of the general appearance of the display can be obtained from Fig. 12 which shows unretouched photographs of typical bearing indications on strong and weak signals, at 122 megacycles per second. The green fluorescence of the CV275 is not very suitable for photography and a rather long exposure (30 seconds) was used; external interference during exposure has increased the angular width of the trace slightly in some cases.

4.2.5 Monitoring and Testing Circuits

These were similar to those of the second experimental model, with the exception of the calibrator. For convenience in manufacture and routine testing, this was constructed as a closed network of fixed non-inductive resistors with 16 tapping-points selected by a rotary stud switch, and corresponding with the cardinal, mid-quadrant and mid-octant bearings.

4.3 REMOTE INDICATION

Remote indication at distances up to 500 feet (cable length) was introduced at a comparatively late stage in the development. Direct parallel connection of corresponding deflector plates of the local and remote oscillographs being impracticable, a cathode-follower "repeater" circuit of four triode-connected CV1091 (EF50) valves was interposed. Transmission of potential variations up to 350 volts necessitated high cathode resistances (50,000 ohms) for power economy, and the limit of signalling distance was set by the discharge time-constant of the line

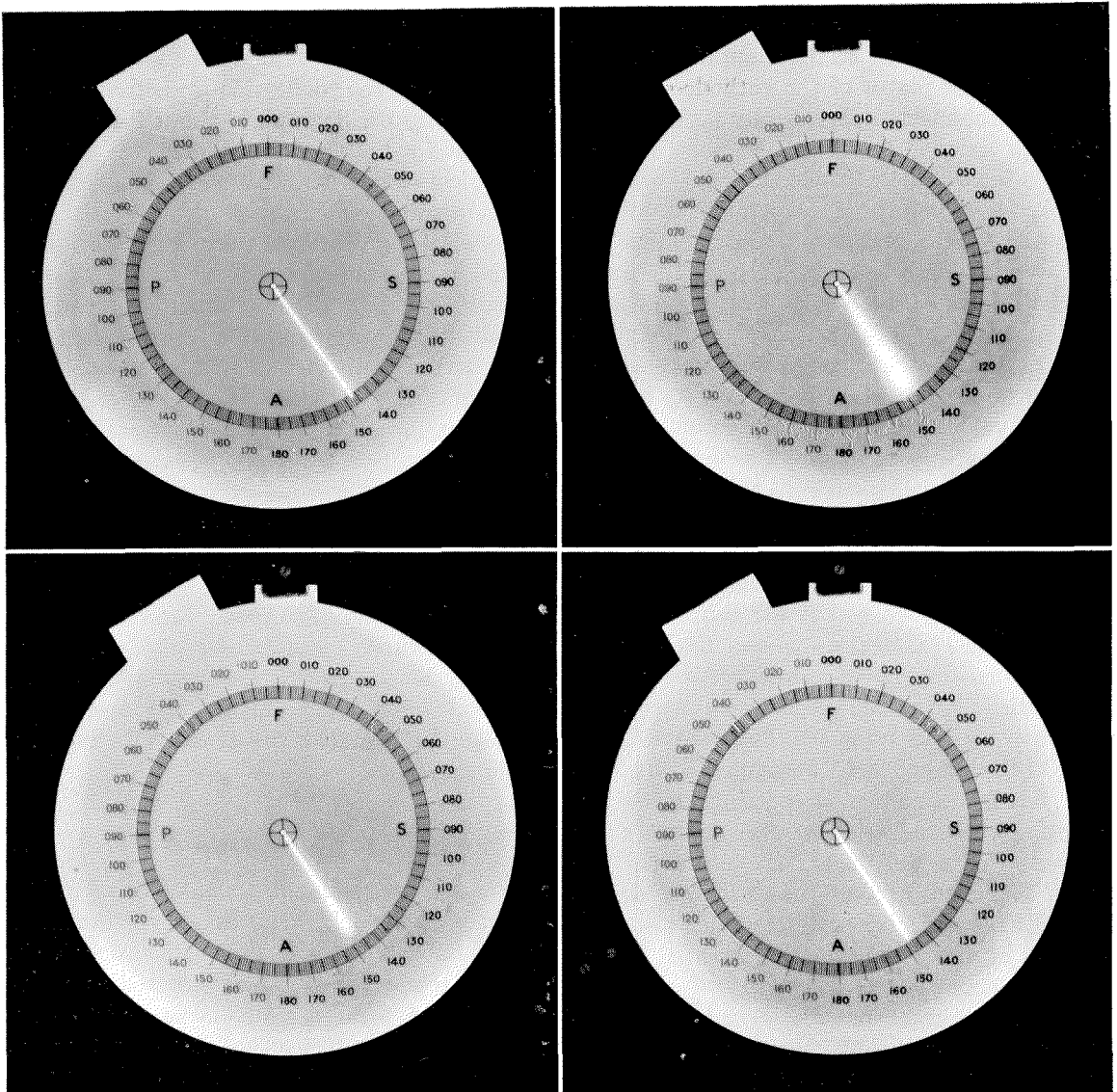

Fig. 12—Typical FV5 bearing indications on cathode-ray tube CV275 (gyro-compass scale and cursor removed). Upper, left—Medium-speed indication, strong signal (about 1 millivolt per metre). Upper, right; Lower, left; and Lower, right—Fast, medium and slow-speed indications on a weak signal (about 6 microvolts per metre).

capacitance/cathode resistance combinations. The curves F_1 , F_2 and F_3 of Fig. 11(b) show the repeater output waveforms corresponding with cable capacitances respectively below, equal to, and above, the maximum for correct operation. Excessive capacitance causes the radial trace on the remote cathode-ray oscillograph to become "detached" from the screen centre. The beam of the remote cathode-ray oscillograph is cut off during the discharge stroke, which is necessarily slower than on the local tube, and might other-

wise cause a prominent and possibly curved "flyback."

Any small relative quadrantal error between local and remote cathode-ray-oscillograph tubes is compensated by a pre-set differential resistive potential divider.

The remote indicator, Fig. 13, includes an oscillograph unit identical with that of the main direction-finder equipment. There are no operational controls other than those required for normal oscillographic adjustments.

4.4 COMPENSATION FOR QUADRANTAL ERROR

Considering the system as a whole, it is clear that although practically all the amplification takes place in a common channel, there remain a number of points in the circuit at which the signals from the two directional-antenna combinations will experience different treatment, resulting in quadrantal error. Compensation for error arising in the low-frequency circuits is made by pre-set adjustment in the differential detector (Section 4.2.2), using a test signal from the calibrator. Any overall quadrantal error is then compensated by differential control of modulator bias, using a vertically polarized test-signal from a source located about 100 feet from the direction-finder antenna system on a mid-quadrant bearing.

In the absence of reciprocal or site errors, it would be sufficient to adjust the indicated bearing of the test signal to the appropriate mid-quadrant reading on the cathode-ray-oscillograph scale. For best accuracy, however, it is generally necessary to take such errors into account by adjusting the indication to a slightly different angle, predetermined as follows:

The antenna system is set successively at the four angles that bring the relative bearing of the source into each of the four mid-quadrant (relative) directions in turn, and after observing the error in each case the mean quadrantal error is computed with due regard for sign, a process which necessarily eliminates the effects of reciprocal and site errors. With normal antenna orientation, the indication on the cathode-ray oscillograph is then re-adjusted to eliminate the computed error, and the indicated bearing is recorded for use in any subsequent re-adjustment. For the most accurate results, the angle is measured for each of the working frequencies.

A method of quadrantal adjustment by direct injection of test signals is under development. While it has the advantage of being independent of site error, there are formidable difficulties in ensuring that the injected signals in each of the three components of the antenna system correspond closely in phase over the whole frequency band with those due to normal reception. In addition, the circuit must be simple and highly stable if it is to serve as a standard of adjustment.

4.5 PERFORMANCE

Data presented in this section relate to the accuracy and sensitivity of the direction-finder as determined by factory tests and field trials. Figures for accuracy are treated on a statistical basis, since the instrumental error of an automatic direction-finder is a function of both frequency and azimuth.

Adequate information on the performance of an FV5 quipment on a good site is lacking, since the few that have been installed temporarily on land have not been subjected to rigorous trials with co-operating aircraft. The performance on board ship is not of general interest since it does not represent, even approximately, that to be expected on land. It has therefore been considered preferable to quote results obtained with the second experimental direction-finder in the course of extensive field trials carried out with the co-operation of Fighter Command, Royal Air Force, at Tangmere, Sussex. The value of these results is enhanced by the fact that simultaneous trials were carried out on a widely used manual direction-finder of good design, installed on an adjacent site.

The results obtained during these field trials are also of value for the indirect evidence which they afford on the performance of the system in



Fig. 13—FV5 remote indicator (for deck-head mounting).

respect of polarization error. No direct quantitative study of this has yet been made.

4.5.1 Instrumental Accuracy

The most useful method of expressing the instrumental accuracy of production direction-finders would be by means of a statistical analysis of the overall errors of a series of complete equipments. Unfortunately it is not practicable to test each equipment as a complete installation. In production, each antenna system is tested with one typical direction-finder office equipment on a permanent test-site. All figures relating to the accuracy of antenna systems therefore include the relatively small errors of this equipment. Each production office-equipment, on the other hand, is tested using its own built-in calibrator, and the errors observed include those of the calibrator circuit which is designed for functional tests and is not really accurate enough to serve as an absolute standard. Finally, the direction-finders cannot be tested with the cathode-ray tubes which will be used in subsequent operation. These facts must be borne in mind when considering the results given below.

In this section statistics are given for the accuracy of antenna systems in conjunction with a typical direction-finder office equipment, for the accuracy of remote indication, and for the accuracy of calibrated cathode-ray tubes, based on the maker's tests. The statistics are supplemented by a number of error curves.

Production tests on antenna systems are made at three frequencies after individual modulators and central antenna amplifiers have been subjected to valve ageing for 50 hours under working conditions (to eliminate any early failures) and a short vibration test simulating mast-head conditions in a ship installation (5 minutes vibration at 10 cycles per second, 0.2 inch amplitude).

Errors are measured in the four cardinal and four mid-quadrant directions by the method indicated above (Section 4.4). Octantal errors, being calculable, are not normally measured.

The results of routine tests on 20 consecutive antenna systems from the production line are summarized in Table 1, which shows the root-mean-square errors for each frequency, in each of the eight directions of measurement, and in Table 2 which shows for each frequency, (a) the

TABLE 2

Frequency in Megacycle per Second	Approximate Probable Error in Degrees	Maximum Errors in Degrees		Percentage of Errors Greater than 2 Degrees	Total Number of Observations
		+	-		
100	0.6	2	2.5	0.7	160
122	1.1	2.5	3.5	3	160
150	1.25	3	3	14	160

probable error, (b) maximum errors and (c) the percentage of errors exceeding 2 degrees.

The distribution of errors for the three frequencies is shown in diagrams (a), (b) and (c) of Fig. 14. Making allowance for the compara-

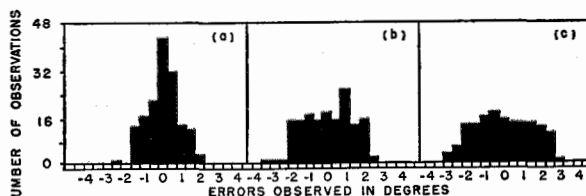

Fig. 14—Distribution of errors on twenty FV5 antenna systems.

tively small number of observations and the fact that errors are only recorded to the nearest 0.5 degree, it is noteworthy that diagram (a), for 100 megacycles per second, is a reasonable approximation to the typical probability-curve of purely random errors, such as those of observation. Diagrams (b) and (c) show quite

TABLE 1

Frequency in Megacycles per Second	Nominal Bearings and Corresponding Errors (Root-Mean-Square Degrees)								Root-Mean-Square Error, All Bearings	Total Number of Observations
	Fore	Starboard			Aft	Port				
	000	045	090	135	180	045	090	135		
100	0.61	0.78	1.03	0.82	0.82	0.95	0.92	0.96	0.87	160
122	0.98	1.23	1.54	1.82	0.46	1.07	1.49	1.61	1.34	160
150	1.06	1.92	1.72	1.46	1.45	1.34	1.34	1.69	1.52	160

different distributions, since at 122 and 150 megacycles per second there are components of reciprocal form, sinusoidal for variation of azimuth. Periodic errors of this type do not give a normal distribution-curve, because the probability that errors will be nearly zero is actually less than the probability that they will be near the maximum for the function. Diagrams (b) and (c) represent the combined effect of errors that vary sinusoidally with azimuth and of random errors of observation.

The accuracy of the remote indicator system is checked by taking error curves with the same cathode-ray tube placed first in the main indicator position, and then in the remote indicator unit. The maximum relative error permitted is 1 degree. The root-mean-square values of relative error for a group of twelve production equipments are given in Table 3, for each of the sixteen test bearings.

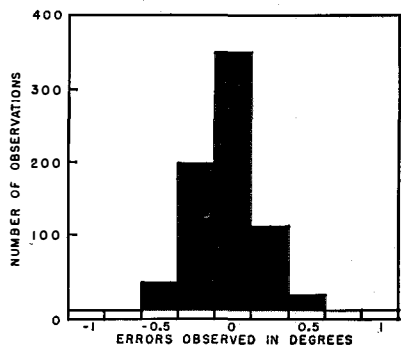

Fig. 15—Distribution of errors on 44 calibrated cathode-ray tubes, CV275.

The accuracy of the calibrated cathode-ray tube Type CV275 is illustrated in the distribution diagram, Fig. 15. This is based on production tests on a run of 44 tubes, measured at angular intervals of 22.5 degrees. The probable

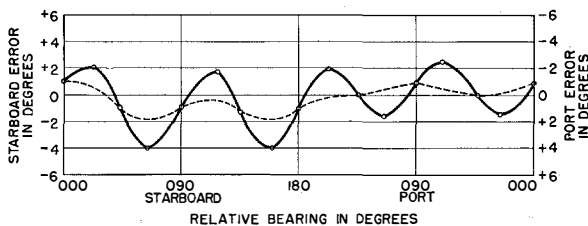

Fig. 16—Typical FV5 instrumental error-curve at 122 megacycles per second. Full line: as taken on uniform scale. Broken line: effect of scale compensation.

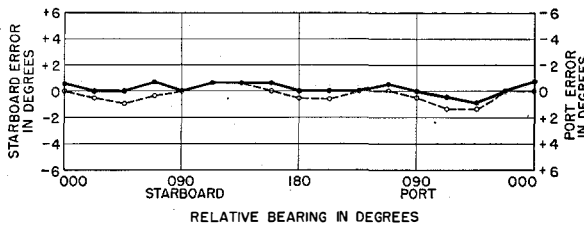

Fig. 17—Apparent errors of typical FV5 indicator circuits. Full line—main indicator. Broken line—remote indicator.

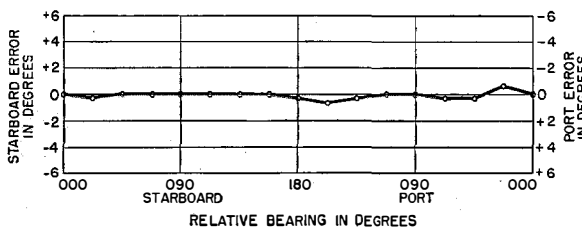

Fig. 18—Apparent errors of indicator circuit used on FV5 antenna test-site.

error appears to be considerably less than 0.25 degree.

The overall error-curve for a typical direction-finder is shown in Fig. 16, which illustrates the effect of using a bearing scale compensated for octantal error to the extent of 2 degrees (maximum). Fig. 17 shows the apparent errors of the low-frequency circuit of a typical production office-equipment, including any error contributed

TABLE 3

Nominal Relative Bearing in Degrees	Fore	Starboard							All Bearings, 192 Observations
	000	022.5	045	067.5	090	112.5	135	157.5	
Relative Error, Root-Mean-Square Degrees	0.52	0.38	0.44	0.42	0.13	0.38	0.21	0.46	0.60
Nominal Relative Bearing in Degrees	Port							Aft	
	022.5	045	067.5	090	112.5	135	157.5	180	
Relative Error, Root-Mean-Square Degrees		0.68	0.58	0.65	0.68	0.60	0.61	0.66	0.31

by the internal calibrator, as explained above. Similarly, Fig. 18 shows the apparent errors of the antenna test-site equipment.

4.5.2 Field Tests on Accuracy

Simultaneous trials were carried out at Tangmere in August–September, 1943, on the second experimental direction-finder described above, and on an Air Ministry manual very-high-frequency direction-finder, Type 2A. They were installed on good average sites about 100 yards apart, and so far as possible bearings were measured simultaneously on the same transmissions.

Test signals were provided by an Avro Anson aircraft flying over a series of “pin-points” on a course embracing the two northern (landward) quadrants, at distances ranging from 25 miles in the east (Brighton), to 55 miles in the west (Wimborne Minster). The heights flown were 2000 to 5000 feet depending on weather conditions and range. Bearings on both direction-finders were observed by Service operators without previous experience of the automatic system. Transmissions were of 5 to 10 seconds duration. All automatic observations have been corrected for the mid-band octantal error of 2 degrees (maximum) as the observations were made on a uniform bearing scale.

Table 4 and the error-distribution diagrams (a) and (b) of Fig. 19 summarize the results of the five main series of observations, which were carried out at 106 megacycles per second (two series) and at 110, 114 and 120 megacycles per second. The two greatest errors recorded on the manual instrument could not be recorded on the distribution diagram (a) due to limitations of space. Test No. 5 was subject to frequent jamming, and the superior performance of the automatic system in this case is noteworthy.

The results as a whole show that the performance of the automatic direction-finder was more consistent, judging from the smaller maximum errors and higher percentage of first-class bearings. However, the best performance on a single series of observations was given by the manual instrument. This result was not unexpected and illustrates the fact that the results obtained with such an instrument depend greatly on the skill of the operator and on the prevailing conditions.

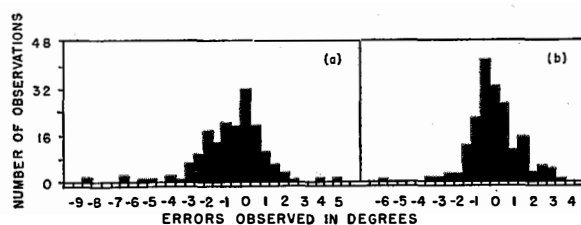

Fig. 19—Distribution of errors for field trials at Tangmere. (a) Manual direction-finder, Air Ministry Type 2A (169 observations). (b) Second experimental automatic direction-finder (186 observations).

The accuracy of the direction-finders on high-angle signals appeared to be about the same, judging from the results of a number of simultaneous qualitative tests on an aircraft flying directly over the direction-finder site. Automatic indications remained fairly steady up to 45 to 60 degrees elevation, after which increasingly violent fluctuations occurred until at the highest angles one or more complete revolutions were sometimes noted. Corresponding effects were observed on the manual instrument—“flattened” minima, variations too rapid to follow, and failure or reversal of sense indication. The instant of passage of the aircraft over the direction-finder site was easier to detect on the automatic equipment owing to its higher speed of operation.

TABLE 4

Test Number	Frequency in Megacycles per Second	Number of Observations		Root-Mean-Square Error in Degrees		Maximum Error in Degrees		Approximate Percentage of Errors Exceeding 2 Degrees	
		Manual	Automatic	Manual	Automatic	Manual	Automatic	Manual	Automatic
1	106	35	41	1.02	1.93	2.5	6	3	24
2	106	27	31	6.66	1.20	26	3	41	6
3	110	40	40	1.37	1.23	2.5	3.5	5	8
4	114	28	34	2.77	1.35	6.5	3.25	32	9
5	120	40	43	2.37	1.07	10.5	2.5	20	5
All tests	—	170	189	3.20	1.40	26	6	18	11

4.5.3 *Effective Direction-Finder Signal-to-Noise Ratio and Deflection Sensitivity*

Signal-to-noise ratio at the bearing indicator is a fundamental measure of the performance of an automatic direction-finder, since, for a specified weak signal, it determines the reading accuracy attainable. In this section signal-to-noise ratios are not given explicitly, but in terms of an inversely related quantity, the "fluctuation angle" (\pm degrees) for signals of known strength.

Deflection sensitivity has little theoretical significance since it can be modified at will by simply changing the overall gain of the common amplification-channel. The gain available in the FV5 equipment is such that all signals that can be identified by speech modulation give a radial trace at least 1.5 inches long (half-scale deflection).

Measurements of fluctuation angle and deflection sensitivity were made on fields of calculable strength. The source of signal was a generator feeding a vertical, elevated, resonant dipole some 20 feet from the direction-finder antennas and at the same height above ground-level. An independent experiment showed that free-space propagation could be assumed without sensible error and the field was calculated from the relation

$$E_v = 60I/d,$$

where E_v = field strength in volts per metre,
 I = antinode current in amperes, calculated from generator output-voltage, and
 d = distance from dipole in metres.

Mean figures quoted in the tables were based on three sets of measurements, made with two generators of the same type and a third of an entirely different type. The spread of individual observations did not exceed ± 15 per cent about the mean figures given.

TABLE 5

Frequency in Megacycles per Second	106	122	150
Field Strength in Microvolts per Metre for 1.5-Inch Trace	6.5	4	2.5

Table 5 shows the mean field strengths required for a 1.5-inch radial trace at three frequencies distributed through the band.

Table 6 shows the approximate fluctuation-angle for the three speeds of indication, for a trace length of 1.5 inches, corresponding to the field strengths of Table 5. For a given trace-length the fluctuation angle was roughly independent of frequency, within the limits of experimental error.

TABLE 6

Indication Speed	Approximate Time-Constant of Differential Detector in Seconds	Approximate Fluctuation-Angle in Degrees
Fast	0.03	± 9
Medium	0.3	± 3
Slow	1.0	± 1

4.5.4 *Field Tests on Effective Range*

An indication of the effective range of the FV5 direction-finder is given by the results of some tests carried out on the second experimental model in the course of the field trials at Tangmere briefly described in Section 4.5.2. Owing to unfavourable weather it was not possible to obtain more than a limited number of observations, mainly at 120 megacycles per second. The aircraft carried a transmitter rated to deliver 5 watts and flew at heights of 6000 to 7000 feet; the direction-finder antenna-system was mounted at a height of 24 feet. Bearings were observed in the north-west quadrant and the trace length was recorded as the aircraft reported position at pre-selected points, identified visually. Trace lengths of 1 to 2 inches (about half-scale deflection) were observed on 8 occasions at an average range of 89 miles, and of 2.5 inches or more on 17 occasions at ranges averaging 75 miles. The results were rather erratic, including a deflection as small as 1.5 inches at only 77 miles, and a full-scale deflection at 98 miles; this was doubtless due in part to the nature of the intervening country and perhaps to the aspect of the aircraft.

The figures suggest a half-scale-deflection range of about 80 miles at 120 megacycles per second for an aircraft at 6000 feet, and a few observations made at 106 megacycles per second suggest a corresponding range of about 70 miles at the lower frequencies in the band 100-125 megacycles per second.

With automatic gain-control in use the deflection-to-range characteristic is very flat up to ranges of 65 to 75 miles (aircraft at 6000 feet),

but falls off extremely sharply for ranges exceeding that at which half-scale deflection is obtained. This is due to the combined effect of the falling-off in field strength according to an inverse square (or higher) law and the square-law rectification of weak signals.

In range, as in accuracy, the results obtained with the manual direction-finder were found to depend greatly on the skill of the operator, but on the average the maximum effective range was about the same for both systems.

5. Very-High-Frequency Automatic Direction-Finders for Land-Station Service

The Admiralty D/F Outfit FV5 is being adapted for use on land, at direction-finder stations associated with civil and military aerodromes. The immediate requirements for this service are remote indication with speech monitoring and facilities for adjusting quadrantal balance in the control tower, while the main direction-finder equipment works unattended on an open site which will generally be at least half a mile from the main aerodrome buildings. Taking a longer view, full remote operation with frequency selection from the control tower is desirable for economy in staff, while simultaneous multi-channel working and interconnection of local and remote equipment over normal telephone lines are equally desirable for economy in plant and transmission circuits.

5.1 DIRECTION-FINDER TYPE P.V.1—A

Adapted to meet the immediate requirements stated above, this is essentially the same as the FV5 except that the bearing repeater circuit has been modified to permit remote indication up to about a mile from the main direction-finder equipment, or up to nearly three miles with the sweep frequency of bearing indication reduced from 135 to 50 cycles per second.

5.1.1 Remote Indicator Circuit

Reference to curve F_3 of Fig. 11(b) (Section 4.3) shows that to increase the range of remote indication of the FV5 system it is necessary either to accelerate the discharge of the line capacitances during the "flyback" periods, or to reduce the sweep frequency. For distances up to about

one mile the former method was adopted,¹³ the discharge being accelerated by electronic switches (triode-connected CV1060) shunted across the cathode-follower load resistances and controlled in parallel by a voltage derived from the radial sweep circuit (Section 4.2.3). By this means the line capacitance which could be discharged effectively at 135 cycles per second was increased from 0.01 microfarad to about 0.15 microfarad. Triode-connected beam tetrodes CV345 were about four times more effective in reducing the discharge time-constant but did not allow a corresponding increase in line capacitance, which at a sweep frequency of 135 cycles per second was limited by the current-carrying capacity of the cathode-followers to about 0.25 microfarad. This corresponds to about one mile of light-gauge lead-covered and rubber-insulated power cable of 660-volt grade.

5.1.2 Stability of Direction-Finder Circuits in Unattended Operation

For stability in unattended operation the most significant adjustments are those of differential detector centering and phasing, and overall quadrantal balance. The latter depends mainly on constancy of relative gain between the antenna modulators.

Stability was investigated in a series of 6 tests of 8 hours and one of 32 hours on a standard Admiralty FV5 equipment. Measurements on the significant adjustments made at hourly intervals yielded similar results in all tests. The results of the final 32-hour test were as follows:

Differential detector-centering measured in terms of cathode-ray-oscillograph deflection was constant within ± 0.75 millimetre throughout the period. Variations of this order might lead to errors up to 1 degree on a weak signal giving half-scale deflection, but as the centering may be corrected at the remote indicator their effects may be discounted.

Differential detector-phasing was constant within ± 1 degree throughout the period. The apparent variations observed were no greater than the limits of experimental error in adjustment, and were clearly so small as to have a completely negligible effect on the quadrantal balance.

Hourly variations of overall quadrantal error are plotted on the graph of Fig. 20 for the three routine test frequencies 100, 122 and 150 megacycles per second. Large variations of alternating-current line voltage are known to affect the quadrantal error, but there is no apparent correlation

¹³ British Patent No. 590261.

in the case of the small variations recorded during the test, also plotted on Fig. 20. The differences between the mean quadrantal errors are due to the fact that the balance adjustment was left untouched throughout the period. The limits of variation for the three frequencies were approximately ± 0.5 degree about the mean values, ignoring the observations of the first two hours.

The variation of quadrantal balance with time is almost entirely due to small changes of uncertain nature associated with the modulator units and central antenna amplifier, and further tests were made to determine the time taken by these elements to reach steady operating conditions. Three pairs of modulators were tested, including the pair used in the 32-hour test. All modulators were tested in association with each pair of directional antennas (6 tests in all), and quadrantal error was measured at intervals of 5 minutes until quasi-stability was reached. It was found that by a coincidence the combination and arrangement used for the 32-hour test gave by far the worst results, requiring 60 minutes to reach a quadrantal error within 1 degree of the final mean error. In the other five tests the corresponding times were 10 minutes or less.

5.2 DIRECTION-FINDER TYPE P.V.1—B

This represents a current development of the FV5 direction-finder and goes further toward

meeting the general requirements already stated. The direction-finder antenna system can be arranged to cover one of the bands 100–118, 118–132 or 132–156 megacycles per second without re-tuning the output circuit. It feeds two receivers tuned to different frequencies, one of which may be reserved for distress calls. The receivers have separate speech-channels in continuous operation, and when a signal is received on either channel, separate visual-warnings are given by neon lamps both in the direction-finder station and at the remote indicators. Under standby conditions, direction-finder signals from both channels are passed to the common indicator-circuit. If signals are received on both frequencies simultaneously the operator can switch the bearing indicator to one channel or the other. Up to three remote indicators can be used, and the system can be controlled either at the direction-finder station or from any of the remote indicators. Obstruction warning lamps can be mounted on the sides of the antenna box when the direction-finder station is located close to an airport.

Remote indication is obtained by the transmission of direct-current deflecting potentials from the differential detectors, using a cathode-follower circuit and a radial-sweep generator at the remote control-point. Leakage resistances as

low as 30,000 ohms have no effect on the accuracy of bearings, and automatic audible warning is given of any leakage capable of affecting the accuracy. High-speed indication (Section 4.2.2) is possible over 20 miles of a special dry paper-insulated cable which also carries the speech and remote-control circuits.

5.3 FUTURE DEVELOPMENTS

These are expected to include full remote-control and indication together with

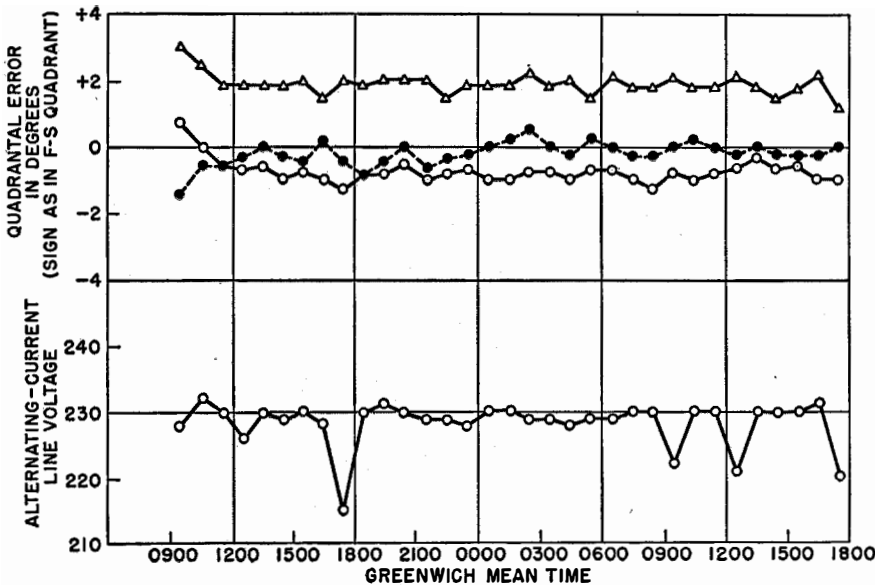

Fig. 20—Quadrantal balance stability of FV5 direction-finder in continuous operation. Operating frequencies in megacycles per second: triangles—150, circles—122, and dots—100.

simultaneous multi-channel operation. Transmission of bearing information over a single circuit is considered essential, both for accuracy and for economy, so retaining the basic feature of the system. The problem has been solved in principle, but discussion of the subject is beyond the scope of the present paper.

6. Special Applications of the System

It is proposed to use a direction-finder similar to the P.V.1—B in a projected navigational system described in a companion paper,¹⁴ in which the position of an aircraft is determined in polar co-ordinates relative to a single base-station, the radial co-ordinate being determined by a co-operative phase-comparison method using continuous waves. In another application the P.V.1—A direction-finder is being used as a means of identifying the indications given by a primary radar system with plan-position display. It is only necessary here to give a brief account of the latter application.

6.1 TRACE IDENTIFICATION IN THE AIRFIELD CONTROL RADAR, BRITISH AIR MINISTRY Mk. IIIx

The A.C.R. Mk. IIIx is a primary radar system giving plan-position indications and is used in the control of aircraft within a radius of about 20 miles from an airport. Dis-

play units are installed in the control tower, and for effective operation it is essential to be able to associate the radar traffic pattern with specific aircraft. The addition of direction-finder indications to the radar display has proved the simplest available method, and although it must occasionally fail when two aircraft appear temporarily on the same line of bearing, a high percentage of identifications is immediately successful.

The P.V.1—A direction-finder station equipment is installed in a small hut about 100 yards from the radar antenna-system, at a point close to the centre of the airfield. The radar and direction-finder indications are obtained on separate oscillograph tubes and combined optically in a special display-unit (Air Ministry

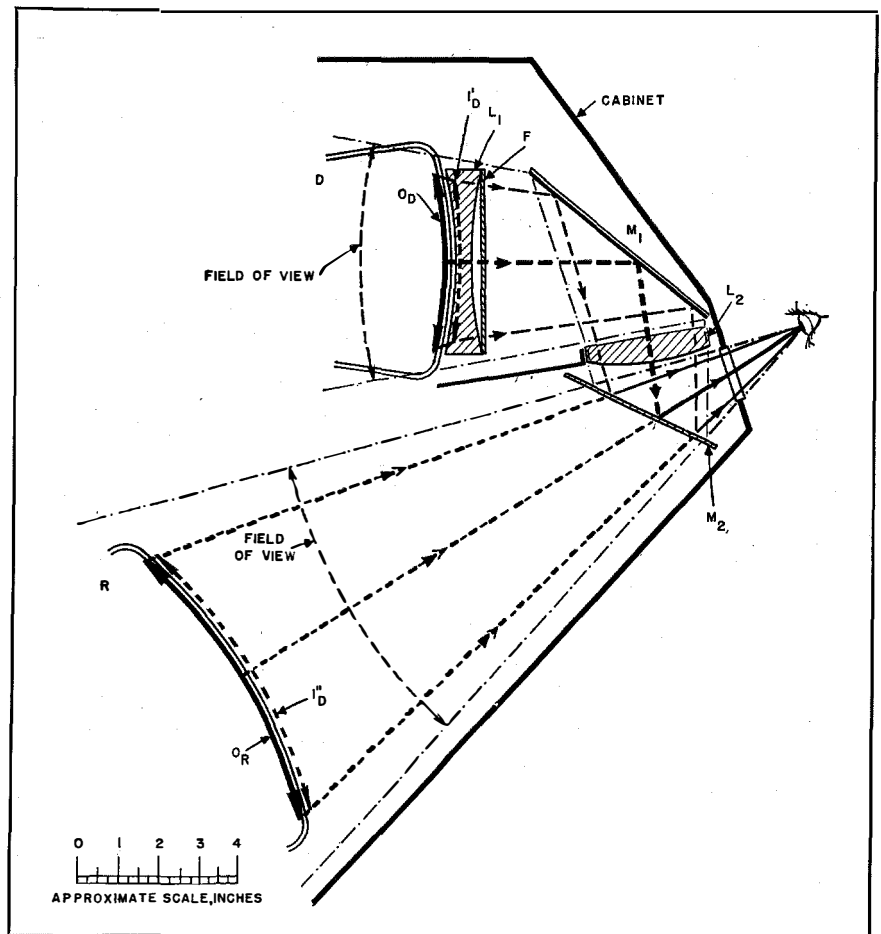

Fig. 21—Optical system of display unit DU74. D, direction-finder oscillograph. R, Radar oscillograph. L_1 , Correcting lens. F, Blue colour filter. M_1 , Polished steel reflector. L_2 , Magnifying lens. M_2 , Plate-glass reflector incorporating yellow colour filter. O_D , direction-finder trace. I_D' , Intermediate image of O_D , curvature corrected. I_D'' , Final image of O_D . O_R , Radar image. (I_D' is normally adjusted to coincide with O_R .)

¹⁴ R. F. Cleaver, "Note on a Short-Range Radio Position-Finding System Using Modulated Continuous Waves," *Journal of the Institution of Electrical Engineers*, v. 94, Part IIIA, p. 984; 1947; and *Electrical Communication*, v. 25, pp. 363-372; December, 1948.

Type DU74). While any system of separate tubes has obvious disadvantages compared with one employing a common oscillograph on a time-sharing basis, there are notable compensating advantages which are apt to be overlooked. First, the use of separate oscillographs makes it possible to display the direction-finder bearings on a screen of short persistence, thus avoiding the confusing afterglow effects which would otherwise occur during brisk direction-finder activity. Further, the direction-finder tube can have a screen fluorescence of low intensity and contrasting colour, giving clearly distinguishable bearing indications without obliterating weak radar signals. Finally, complete electrical separation of the direction-finder and radar circuits simplifies maintenance and reduces the risk of simultaneous failure of both parts of the system.

The principle of the optical system used in the display unit is illustrated in Fig. 21, while Fig. 22 shows the corresponding side view of the display unit with covers removed.

Referring to Fig. 21, R_1 and D represent in cross-section the radar and direction-finder tubes, R having a long-persistence screen with yellowish phosphorescence, and D a screen giving blue fluorescence of short persistence. M_1 is a metallic reflector and M_2 is an unsilvered plate-glass partial reflector incorporating a yellow colour-filter. The radar screen is observed directly through M_2 , which largely suppresses the fluorescence or "flash," and the direction-finder indication is viewed by double reflection at M_1 and M_2 . Back-surface reflection of the direction-finder trace at M_2 is eliminated by the combined action of the yellow filter in M_2 and a complementary blue filter, F, in front of the direc-

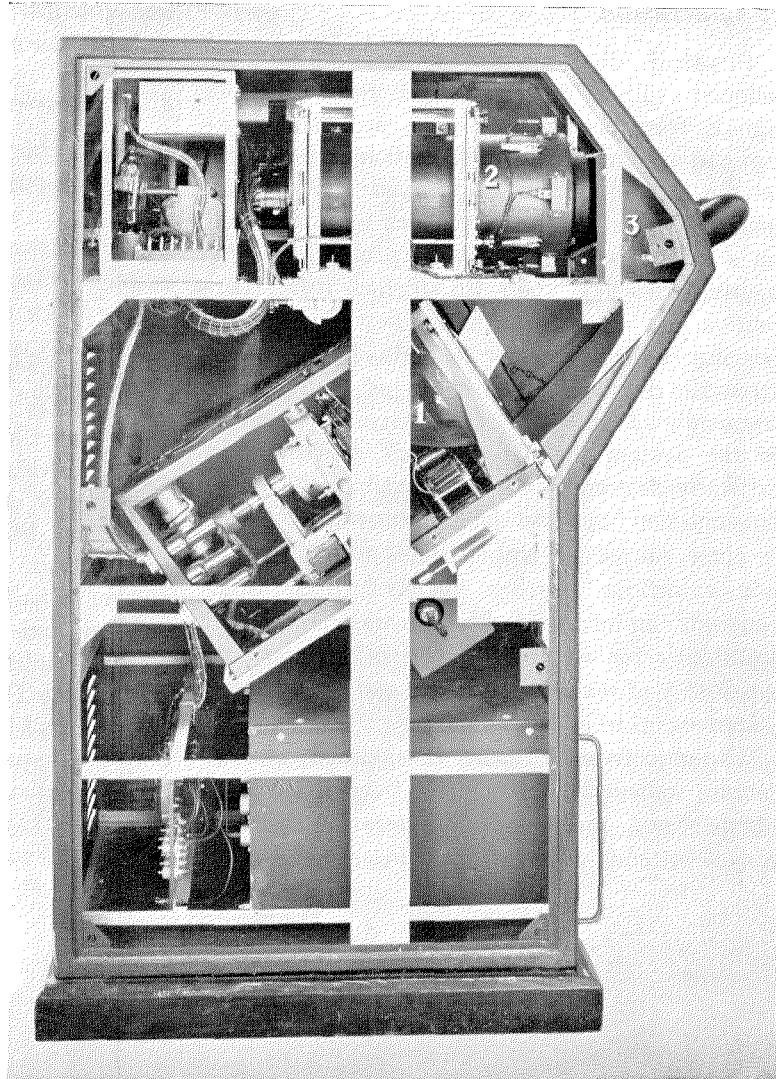

Fig. 22—Display unit DU74 with side cover removed. (See optical diagram, Fig. 21.) (1) Cathode-ray tube, plan-position indicator. (2) Cathode-ray tube, direction-finder. (3) Optical unit.

tion-finder tube. The magnifying lens L_2 makes it possible to use a relatively small (7-inch) direction-finder tube and to mount it further forward than would otherwise be possible. The bi-concave contact lens L_1 corrects the apparent curvature of the image of the screen of the direction-finder tube, and virtually eliminates parallax over the whole of the field of view. All mechanical adjustments necessary to bring the two screens into the correct relative position and orientation are provided on the mountings of the direction-finder tube.

7. Conclusion

Practical direction-finders have been developed utilizing the principle of amplifying the signals from fixed, orthogonal antenna structures in a common channel. Instruments for use in the very-high-frequency band 100 to 150 megacycles per second have been manufactured on a production basis, with a probable instrumental error less than 1.5 degrees (after correction for octantal error). They give useful bearing indications for signals having field strengths down to 7 microvolts per metre at the frequency of minimum sensitivity. Advantages of the system include accuracy which is not critically dependent on the length of the single transmission line from the antenna system to the receiver, simple and stable circuit adjustments, a non-ambiguous bearing display whose time-constant can be adjusted within wide limits, and suitability for unattended operation with the possibility of remote indication and control over distances up to at least 20 miles.

The objectives of future development include remote indication and control over trunk telephone lines, multi-channel operation from a single antenna-system, and improvement in

instrumental accuracy, possibly by the use of wide-aperture antenna-systems.

8. Acknowledgments

The author wishes to record his appreciation of the co-operation of many colleagues in the work described in this paper, and regrets that personal acknowledgment is impossible in most cases. Specific reference must, however, be made to the work of the team headed by Mr. L. J. Heaton-Armstrong, responsible for the engineering of the FV5 equipment, and to the part played by Mr. C. W. Earp, whose advice and encouragement were throughout invaluable.

The development was initiated on the responsibility of Mr. C. E. Strong, Chief Radio Engineer, Standard Telephones and Cables, Limited, and most of the later work was carried out on behalf of the Ministry of Aircraft Production and the Admiralty Signal Establishment. Thanks are due to the Board of Admiralty and to the Directorate of Communications Development, Ministry of Supply, for permission to publish the paper.

The statistical information on the accuracy of the CV275 (Fig. 15) is reproduced by courtesy of Edison Swan Electric Company, Limited.

Note on a Short-Range Radio Position-Finding System Using Modulated Continuous Waves*

By R. F. CLEAVER

Standard Telephones and Cables, Limited, London, England

THE PAPER describes a position-finding system by which the polar co-ordinates of any suitably equipped aircraft can be determined at a single base station using phase-comparison range-finding apparatus and a very-high-frequency automatic direction-finder in conjunction with conventional communication equipment.¹

An experimental model is described in which azimuth and range are displayed on a single cathode-ray oscillograph, which may be installed in an airport control tower. Range is indicated without ambiguity up to 100 nautical miles, and there is no azimuthal ambiguity. So far, the model has been used primarily to demonstrate the principles of the system, in conjunction with an aircraft fitted with experimentally modified British Air Ministry very-high-frequency communication equipment. The results of a limited number of tests suggest that with airborne equipment specifically designed for use with the system, the probable error in range measurement should be less than 1 mile. Azimuthal accuracy is not here discussed, but in a companion paper it is shown that the probable instrumental error of the direction-finder is less than 1.5 degrees, implying a probable lateral error less than 2.5 miles at the maximum non-ambiguous range of 100 nautical miles.

• • •

1. Introduction

Radio position-finding systems for aircraft fall into three classes characterized by their dependence on the measurement of two azimuths, of a range and an azimuth, or of two

ranges. The present paper is concerned with a new system of the second class in which the position of the aircraft is measured at a ground-based station. Continuous-wave transmissions are used in the measurement of both range and azimuth, and the system is cooperative in the sense that a signal transmitted from the ground is repeated back from the aircraft. In these basic respects the system resembles the earlier German "Y" system (British nomenclature: "Benito"), though it differs radically in circuit technique and in the manner in which the positional information is presented.

In the new system, an automatic direction-finder of a type described in a companion paper² is used to indicate the bearing of the co-operating aircraft by means of a radial unidirectional trace on the screen of a cathode-ray oscillograph. The manner in which the radial trace is generated makes it particularly suitable as a time base for the measurement of range, and it is to this fact that the present system owes its origin.

So far, work on the system has been exploratory. An experimental model has been constructed for use either as a short-range navigational aid, or to facilitate the control of aircraft movements in the outer approaches to an airport, indication being given directly in the control tower. The position of any one co-operating aircraft can be established in a few seconds in the absence of significant interference, which, if present, is apparent to the operator.³ The experimental model operates on continuous-wave or telephony-modulated signals transmitted in the very-high-frequency band 100–150 megacycles per second, these signals being used also to

* Reprinted with minor additions from *Journal of the Institution of Electrical Engineers*, v. 94, Part IIIA, n. 16, pp. 984–989; 1947.

¹ The system has become known under the synthetic name "Condar" derived by abbreviation from "continuous-wave direction- and range-finder."

² R. F. Cleaver, "The Development of Single-Receiver Automatic Adcock Direction-Finders for Use in the Frequency Band 100–150 Megacycles per Second." *Journal of the Institution of Electrical Engineers*, v. 94, Part IIIA, n. 15, pp. 783–795; 1947; also *Electrical Communication*, v. 25, 337–362; December, 1948.

³ The effects of interference in the direction-finder used are discussed in the companion paper previously cited.

identify the co-operating stations by the normal communication procedure. A demonstration of the experimental model was given for delegates to the Provisional International Civil Aviation Organization at the Royal Aircraft Establishment, Farnborough, England, in September, 1946.

In the experimental form of the system described in the paper, both direction and range are measured by means of signals which can be transmitted and received by normal communication equipment with comparatively small modifications, so that a minimum of additional equipment is required in the aircraft. The service offered is equivalent to that obtainable from a group of direction-finding stations arranged for triangulation and providing automatic indications on a common cathode-ray oscillograph at a central plotting station. In cases where such an arrangement would be a practicable alternative, the new system offers considerable economies in staff, equipment, lines and buildings. Moreover, since the ground equipment can be concentrated in a very small area if necessary, the system has the further advantage that it can operate in areas where the triangulation method would be uneconomic or inapplicable, e.g., at key points on long air routes over undeveloped or desert country, or in the neighbourhood of island bases on transoceanic routes respectively.

These advantages are obtained at the expense of (a) modifications to the aircraft very-high-frequency communication equipment, involving an increase in weight which might be as little as 2 pounds in a favourable case, but which might be as much as 12 pounds, and (b) the use of separate frequencies for air-to-ground and ground-to-air communication. The necessity for two frequencies is not an unmitigated disadvantage, since it improves the efficiency of communication considerably, and is sometimes favoured on this score alone. Further, in those areas where position-finding by triangulation is impracticable, it is unlikely that the allocation of a second frequency would present any difficulties.

2. Principle

An aircraft receives from the ground station a carrier wave of frequency f_1 modulated at a fre-

quency f_R , and simultaneously transmits a second wave, frequency f_2 , carrying modulation of the same frequency and phase, derived from the received signal. The polar co-ordinates of the aircraft position are determined at the ground station by an automatic direction-finder tuned to the aircraft transmitting frequency f_2 , and by a range-finder which operates by measuring the phase difference ϕ between the modulations on the signals transmitted from, and received at, the ground station. The distance d is indicated directly, and is related to the phase difference in degrees by the equation

$$d = \frac{\phi c}{720 f_R}, \quad (1)$$

where the same units of length are used for d and for c , the velocity of light.

The direction-finder gives the bearing indication on the cathode-ray-oscillograph screen in the form of a radial trace generated by exponential outwardly directed sweeps of the electron beam, synchronized with the modulation so as to provide a time base on which the position of the aircraft may be displayed and its range measured. The measurement is made with reference to an electronic scale marked on the time base, or by means of an electronic "cursor" controlled by a calibrated phase-shifter. These methods were adopted because the physical length of the time base depends to some extent on the received signal strength.

2.1 CHOICE OF CARRIER FREQUENCIES

The association of exploratory work on the system with direction-finder developments in the frequency band 100–150 megacycles per second resulted in the use of frequencies in this band for both f_1 and f_2 . In fact, however, the only theoretical limitation in the choice of frequencies is that, within the working range of the direction-finder, both the signals should travel by paths not differing appreciably in length from the distance between the aircraft and the ground station. This admits considerable freedom of choice in respect of the ground-to-air frequency f_1 , even though availability of direction-finder equipment at present restricts the choice of f_2 to frequencies in the particular very-high-frequency band mentioned.

2.2 CHOICE OF MODULATION FREQUENCY

This is essentially a compromise between the conflicting requirements of high accuracy on the one hand and freedom from ambiguity on the other. If instability of circuit phase-shift and limitations in the measuring technique result in a probable error of $\delta\phi$ degrees in the measurement of the phase shift in transmission, and if the accuracy required is specified by a probable error δd , the modulation frequency is given by

$$f_R = \frac{c\delta\phi}{720\delta d} \quad (2)$$

Since $\delta d/\delta\phi$, and hence f_R , are fixed by the accuracy specified, the first ambiguity is encountered at a distance D , where

$$D = \frac{360\delta d}{\delta\phi} \quad (3)$$

In the present system, it should be possible to maintain $\delta\phi$ at 4 degrees or less,⁴ and from (3) the corresponding probable error in range measurement should not exceed about 1 per cent of the maximum non-ambiguous range. If the latter were arranged to exceed the greatest very-high-frequency communication range currently attainable, the accuracy would be insufficient at the more usual operating distances. By way of compromise, the modulation frequency has been chosen to give no ambiguity up to 100 nautical miles, a conservative figure for the maximum range of the direction-finder for an aircraft at an altitude of 10,000 feet. When there is a possibility that the co-operating aircraft may be in com-

⁴ This assumes that the strength of the carrier wave received from the aircraft is great enough to ensure something like full-scale deflection on the oscillograph. This assumption is justified for all ranges and altitudes at which the aircraft could be identified by the speech modulation on carrier waves received from it.

munication at a distance exceeding 100 nautical miles, it will generally be possible to resolve ambiguity by consideration of received signal strength, the height and estimated position of the aircraft, and other relevant factors.

The modulation frequency corresponding to a phase shift of 360 degrees at a range of 100 nautical miles is 808.9 cycles per second (taking $c = 2.9978 \times 10^{10}$ centimetres per second) and for practical purposes this is rounded off to 809 cycles per second. The range accuracy obtainable with a phase shift of 3.6 degrees per nautical mile should be adequate over most of the normal service area of the direction-finder, and generally consistent with the lateral accuracy attainable.

For the measurement of very short ranges, considerably greater accuracy would be appropriate, and would require the use of a second, higher modulation frequency, a lower frequency being retained for the resolution of ambiguity. In the German "Y" system (Siemens model) frequencies of 300 cycles per second and 3000 cycles per second were used in this way,⁵

⁵ In the later "Graetz," "Rechlin" or "Becker-Gestell" system, a frequency shift (3000-3300 cycles per second) was used, with equivalent result.

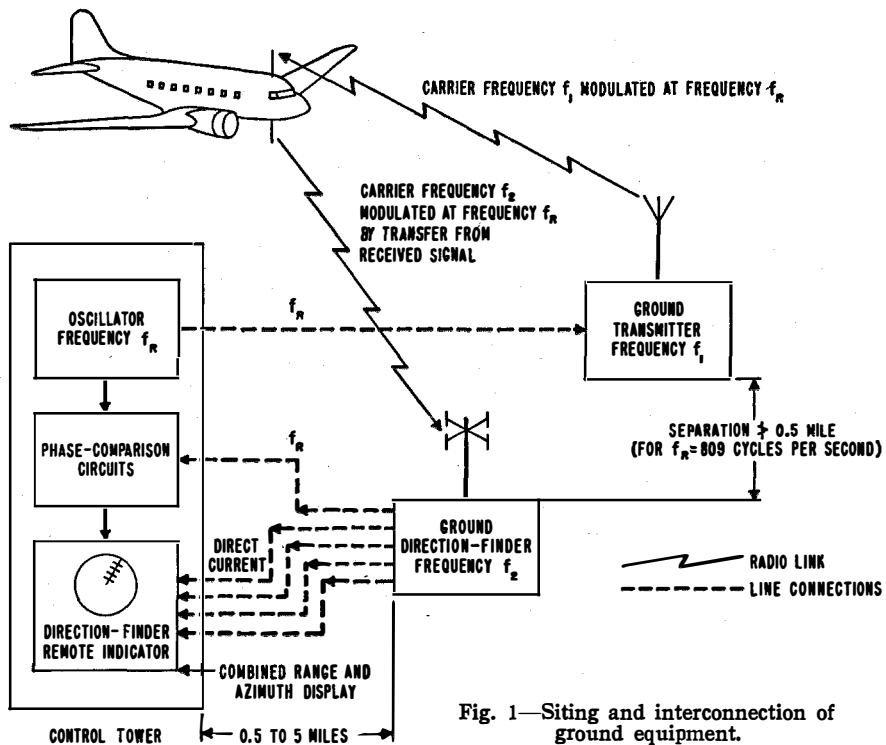

Fig. 1—Siting and interconnection of ground equipment.

corresponding to phase shifts of 1.34 and 13.4 degrees per nautical mile, respectively. The lower frequency resolved ambiguity up to 270 nautical miles (500 kilometres), and it is claimed that an operational accuracy "within 0.5 mile" was obtained.

3. *Siting and Interconnection of Ground Equipment*

A convenient arrangement of ground equipment is illustrated in Fig. 1. The operating position may be in the control tower of an airport, the equipment here consisting essentially of a direction-finder remote indicator, a source of modulating tone for range determination, and circuits for range calibration and remote control of the direction-finder and transmitter.

The transmitting and direction-finder stations are located on adjacent sites which may be up to several miles from the control tower. In general, the spacing between the former will be several hundred yards, the minimum distance being set by considerations of direction-finder site error. Any spacing whatever renders the position determination subject to what may be termed a "parallax" error, of which the law of variation depends upon the point selected as the origin of coordinates, and of which the magnitude increases with the spacing. Errors in range measurement are minimized by taking the origin at the mid-point of the line joining the direction-finder and transmitting antennas, while azimuthal errors are clearly a minimum if the direction-finder antenna system is taken as the origin. In both cases the maximum parallax error is equal to half the spacing between the direction-finder and transmitting antennas, and should preferably be small compared with the probable instrumental error of the system. In

the particular form of the system described in the paper, the spacing could be as much as 0.5 mile without introducing significant error.

Land-line connections convey the modulating tone from the control tower to the transmitting station, and the output at modulation frequency from the direction-finder receiver back to the tower, for phase comparison. Phase shifts in these lines, and in the ground equipment circuits, are compensated at the operating position by a pre-set adjustment which can be checked at any time in a few seconds. Bearing information is transmitted to the remote indicator in the form of four steady potentials, over a separate 4-wire line, and the quadrantal balance of the direction-finder may be checked and corrected by the use of a signal generated at the direction-finder site and controlled from the tower. In addition to the lines mentioned, conventional circuits are

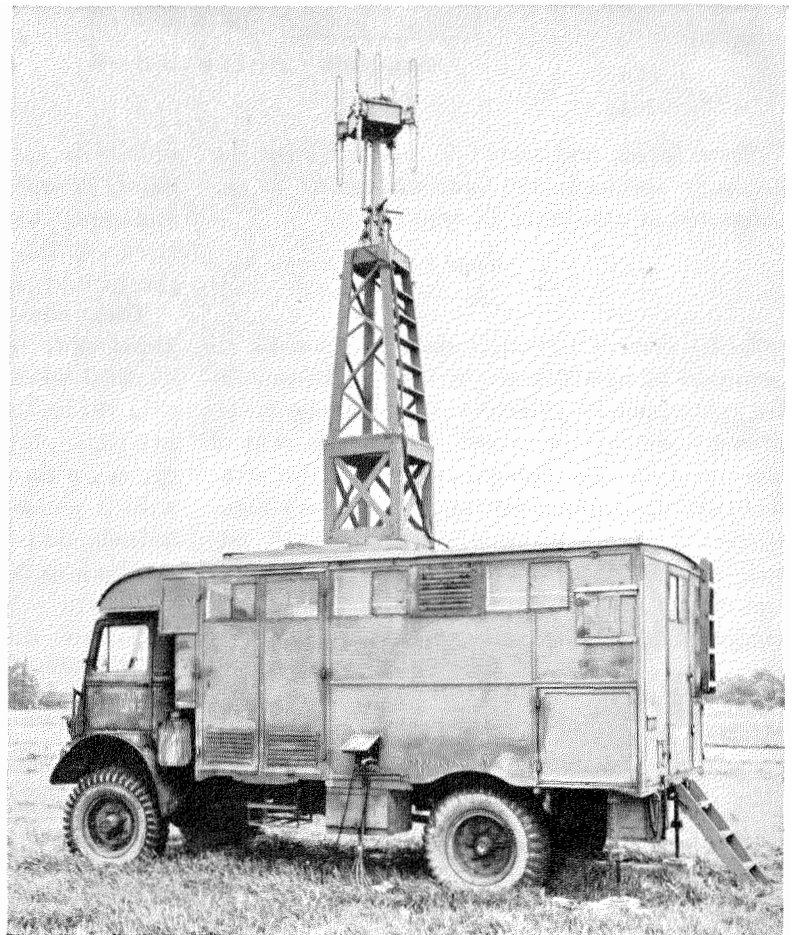

Fig. 2—Mobile direction-finder station.

provided for remote control of the transmitter and direction-finder.

As an alternative to the arrangement described above, it might be advantageous in some cases to use a separate ground receiver for range determination. For maximum accuracy in position finding, the direction-finder station would then be located midway between the transmitting and receiving antennas.

4. An Experimental Model

The model of the system used for the Provisional International Civil Aviation Organization demonstrations employed a single modulation frequency of 809 cycles per second. With the exception of the experimental control-tower apparatus, it was assembled from the most readily available

current Service equipment, modified when necessary, and, in the case of the air-borne very-high-frequency communication set, not particularly suitable for the purpose.

The whole of the ground equipment was installed on an open site close to the aerodrome boundary. The transmitter, Air Ministry type T.1131, and the direction-finder, Admiralty D/F Outfit FV5, were housed in motor vehicles placed about 250 yards apart. The direction-finder vehicle is shown in the photograph, Fig. 2, with the antenna system mounted on a wooden tower at a height of about 22 feet. The transmitter was provided with a vertical quarter-wave

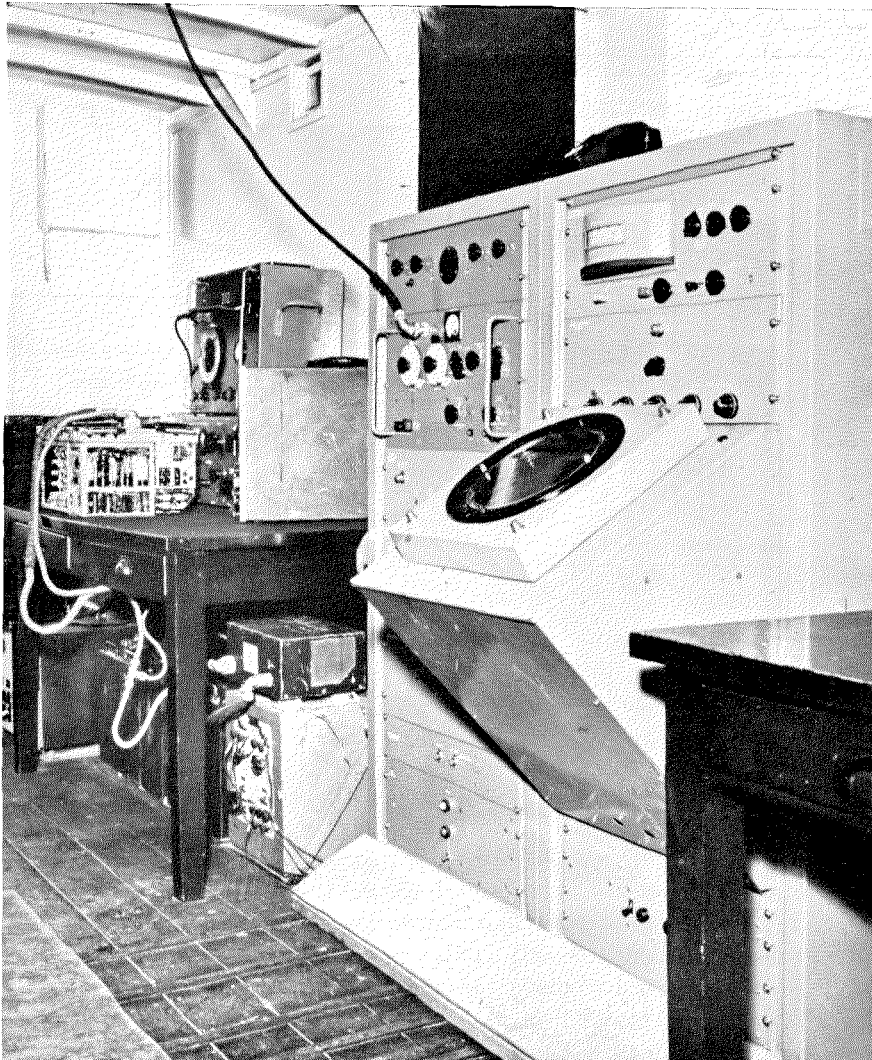

Fig. 3—Experimental control-tower equipment. Aircraft communication equipment TR-1143A on test bench in background.

aerial with horizontal counterpoise, at a height of 25 feet. The control tower equipment, illustrated in the foreground of Fig. 3, was installed in a trailer about 80 yards from the direction-finder vehicle. The interconnection was as described in the previous section.

For demonstration purposes, an Avro Anson aircraft was fitted with an Air Ministry very-high-frequency communication equipment, type TR.1143A, experimentally modified as described in Section 4.3. This equipment can be seen in the background of Fig. 3, set up on a test bench for lining-up.

Fig. 4 shows the complete circuit in block

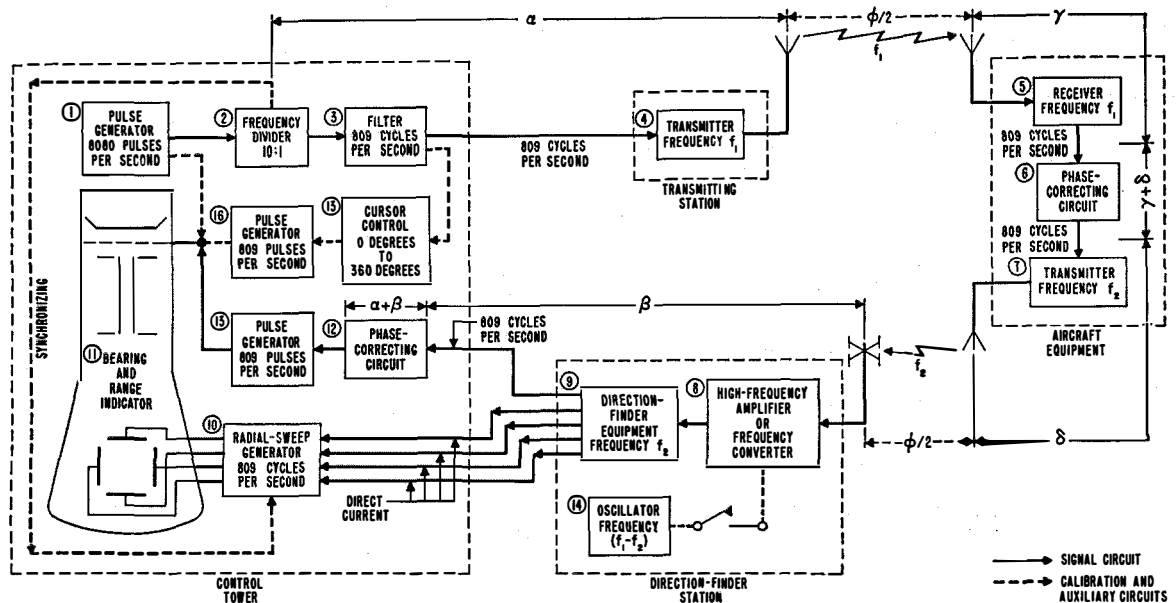

Fig. 4—Block schematic circuit diagram.

schematic form, only the experimental sections being indicated in any detail.

4.1 SIGNAL CIRCUIT

The modulating tone at 809 cycles per second originates in the control tower, where the equipment includes a master oscillator running at 8090 cycles per second, driving a pulse generator (1) followed by a 10:1 frequency divider (2) and filter (3) whose sinusoidal output at 809 cycles per second is sent over a land-line to the transmitter (4) to modulate a carrier wave of frequency f_1 . This is received in the aircraft (5), and the 809-cycle-per-second component from the receiver second detector passes through a phase-correcting circuit (6) to the transmitter (7), to modulate the radiated signal, frequency f_2 . This is picked up by the direction-finder antennas, amplified (8) and applied to the direction-finder equipment (9). Output from the latter includes a component at 809 cycles per second whose phase relative to the modulation on the signal radiated from the ground is a measure of the range, and four steady deflecting potentials whose relative magnitudes are determined by the direction of arrival of the signal. The 809-cycle-per-second and direct-current components of the signal are conveyed over suitable land-

lines to the control tower, together with speech output from the receiver. In the control tower the steady potentials are converted into exponential saw-tooth form at a frequency of 809 cycles per second in the radial-sweep generator (10), and are then applied to the deflector plates of the cathode-ray-oscillograph bearing and range indicator (11) to produce a radial trace on the screen. The component at 809 cycles per second passes through the phase-correcting network (12) to a pulse generator (13) whose output is applied to the grid of the cathode-ray oscillograph (11), producing a bright spot on the radial trace at a distance from the centre depending on the range of the aircraft. The outward radial sweep is synchronized with the modulation on the ground transmitter by an auxiliary connection from the 10:1 frequency divider (2) to the sweep generator (10).

The duration of the sweep can be adjusted to be just over one-half of a cycle of modulation at 809 cycles per second, so that ranges up to 50 nautical miles (180 degrees of phase shift) can be displayed. By reversing the phase of the modulation on the ground transmission, the apparent phase shift is reduced by 180 degrees so that ranges from 50 to 100 nautical miles can be measured on the same time base. This arrangement effectively doubles the length of the ex-

ponential range scale, which for the normal full-scale deflection averages 1.8 millimetres per nautical mile, and has a maximum value of about 2.5 millimetres per nautical mile at the central origin of the time base.

The positional accuracy of the system depends upon two pre-set adjustments which are made in the control tower, and may be checked in a few seconds at any time. These adjustments, described in Sections 4.1.1 and 4.1.2, affect range and azimuthal accuracy respectively.

4.1.1 Zero Range Adjustment

Unavoidable phase shifts in the ground transmitting and receiving circuits (α and β , Fig. 4) are corrected in the network (12). The adjustment is made with the direction-finder receiver temporarily retuned to the ground transmitting frequency f_1 by means of a frequency changer formed by amplifier (8) in association with the beat oscillator (14) which may be switched on from the control tower. The range indication is adjusted to one-half of the distance between the ground transmitter and the direction-finder station.

4.1.2 Quadrantal Balance Adjustment

The quadrantal balance of the direction-finder may be checked and adjusted if necessary, using a test signal on a mid-quadrant bearing, provided by an oscillator under the control of the operator.

4.2 RANGE CALIBRATION CIRCUIT

On the experimental model, two methods of measuring range on the radial time base are provided. In the first, positive pulses from the generator (1) are applied to the grid of the cathode-ray oscillograph and produce bright spots on the radial time base, constituting an electronic scale with intervals of ten nautical miles. The range of an aircraft can then be obtained rapidly by interpolation with sufficient accuracy for many puposes. The second method of measuring the range is by means of an "electronic cursor." An output from the 809-cycle-per-second filter (3) is passed by way of a calibrated phase shifter (15) to a pulse generator (16) whose output is applied to the grid of the cathode-ray oscillograph. The corresponding bright spot on the radial trace constitutes the "cursor," and is brought into coincidence with the aircraft indication by the phase shifter (15), whose calibration (in miles) then indicates the range. A zero adjustment not shown in Fig. 4 is used for initial alignment of the phase shifter against the electronic scale previously described. The phase shifter is continuously adjustable from 0 to 360 degrees with uniform calibration, and is similar in principle (see Section 7) to the angular calibrator used on the direction-finder.

The scale and cursor indications are distinguished from that due to the aircraft by an artifice not shown in Fig. 4. The calibrating

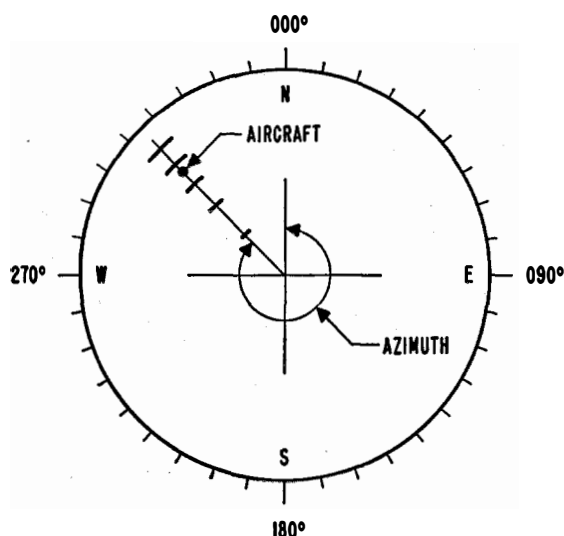

Fig. 5—Range and azimuth display, with electronic scale of 50 nautical miles. Aircraft at 36 nautical miles.

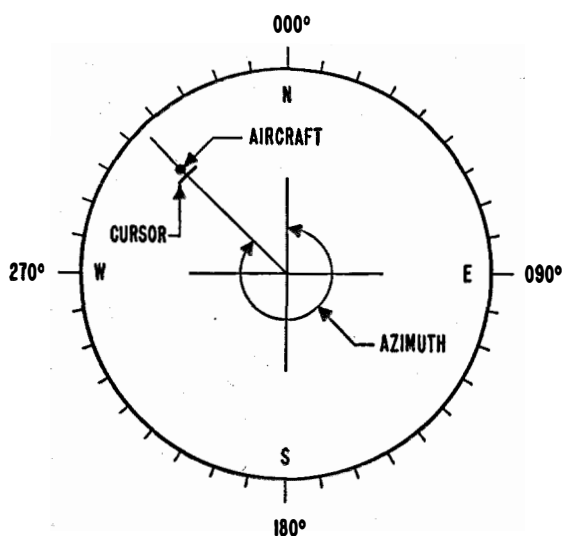

Fig. 6—Range and azimuth display, with electronic cursor. Aircraft at 36 nautical miles. Cursor at 33 nautical miles.

pulses are applied to the cathode-ray oscillograph control grid during alternate sweeps of the radial time base, and the pulse due to the aircraft is applied only during the intervening sweeps. An angular oscillation, of about 5 degrees amplitude and at a frequency of about 200 kilocycles per second, is imposed on the radial time base during calibration sweeps only, thus converting the scale and cursor spots into short arcuate lines. A negative bias applied to the cathode-ray oscillograph grid during calibration sweeps extinguishes the radial trace except at the instants when pulses occur. Figs. 5 and 6 illustrate the forms of indication obtained with the alternative methods of measuring the range. In Fig. 6, the cursor trace is shown displaced by about 3 miles from the "aircraft" spot, which is at a point corresponding to 36 miles.

4.3 AIRCRAFT EQUIPMENT

The TR.1143A aircraft equipment was modified for demonstration purposes as follows:

- A. Two quarter-wave antennas were provided to permit simultaneous transmission and reception, in place of the common antenna and change-over relay arrangement normally used.
- B. A small control box was added, containing a key which, overriding the normal control box, arranged the circuit for simultaneous transmission and reception on two predetermined frequencies. At the same time, output from the receiver was connected to the modulation amplifier of the transmitter.
- C. A simple phase-correcting circuit [(6) in Fig. 4] was introduced between the receiver and the modulation amplifier.
- D. The modulation amplifier was modified by the application of automatic gain control to the first stage, derived from the modulator output voltage.

The modifications involved an additional weight of about 2.5 pounds, using components of normal size. It may be noted here that in cases where the normal very-high-frequency equipment is fundamentally unsuitable for simultaneous transmission and reception, it would be necessary to provide a separate miniature receiver, weighing perhaps 10 pounds.

Modulation-frequency phase shifts in the aircraft equipment (γ and δ in Fig. 4) are corrected in the adjustable network (6) interposed between receiver and transmitter. This is pre-set during circuit alignment on the ground, by

applying to the receiver a signal modulated at 809 cycles per second from a generator, and equalizing the phases of the generator modulating voltage and the corresponding voltage appearing at the output terminal of the transmitter modulator.

4.4 EXPERIMENTAL RESULTS

The Farnborough installation was used almost entirely for demonstration to the Provisional International Civil Aviation Organization and other delegations, under conditions that precluded systematic recording of significant observations. One of the few recorded tests was made to determine the maximum effective range of the system with respect to an aircraft at a height of 2000 feet and its results may be of interest.

The aircraft flew on an outward radial track, ranges obtained by direct visual observation being reported at intervals of 5 statute miles; simultaneously, measurements were made by the electronic cursor method, and in Fig. 7 the errors are shown plotted against reported range. The observation at zero (plan) range has been corrected for the height of the aircraft. Circles in Fig. 7 correspond to the errors of mean measured ranges, while the thick vertical lines show the extent of the "spread" due to fluctuation noise. The maximum effective range for the conditions of the test can be seen to be about 35 miles, at which distance a "spread" of about ± 5 miles and an error of -1.5 miles were obtained. At a range of 40 miles, the signal-to-noise ratio was so low that speech was scarcely intelligible in either direction, showing that the useful ranges for

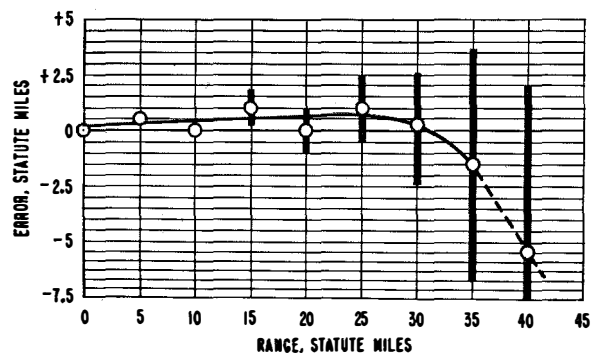

Fig. 7—Range test on an aircraft at a height of 2000 feet. $f_1 = 100.8$ megacycles, $f_2 = 110$ megacycles.

speech communication and distance measurement were about the same. Up to 30 miles, the maximum overall error did not exceed 1 mile, and the distribution of errors suggests a reading accuracy not worse than ± 0.5 mile. It should be noted that the instrumental accuracy depends fundamentally on the frequency of the master oscillator, nominally 8090 cycles per second, which on the experimental equipment was not crystal-controlled and was not checked after leaving the factory. Observations at the shorter ranges suggest that the oscillator may have been running some 2 to 3 per cent fast.

During the demonstrations, the greatest errors observed were due to variations in modulation-frequency phase shift in the airborne equipment, which in the course of a flight of several hours sometimes amounted to the equivalent of 2 to 3 miles. It should perhaps be emphasized that the circuit of the TR.1143A was standard in all essential respects, and no attempt had been made to improve it in respect either of magnitude or stability of phase shift. Reference to the figures given in Table 1 for a particular equipment

TABLE I

TR.1143A COMMUNICATION EQUIPMENT
Measured Phase Shifts at 809 Cycles per
Second (Phase Reversals Neglected)

Section	Phase Shift in Degrees
Receiver High- and Intermediate-Frequency Amplifiers	- 6*
Receiver Second Detector (Filter Circuit)	- 42
Transmitter Modulation Amplifier	+ 30
Complete Equipment	- 18

* Modulation envelope shift.

shows that, although the resultant phase shift is not very great, there are substantial shifts in individual sections of the circuit, a factor which militates against stability.

Subsequent tests showed the phase shift in the transformer-coupled modulation amplifier to be particularly undesirable, since it was dependent to a marked degree on the input voltage to the motor generator from which the equipment drew its power. The average effect was to introduce error at the rate of about 0.1 mile for each 1 per cent drop in battery voltage from the value used during alignment on the ground. Since in flight the equipment was supplied from an auxili-

ary battery, and was generally in continuous operation for two or three hours, the observed variations in phase may well have been largely due to supply-voltage changes. In any communication equipment specifically designed or modified for regular operation with the system it is clear that special attention must be paid to low-frequency transformer-coupled stages.

5. Conclusion

The work described demonstrates the practicability of a direct-reading ground-based position-finding system utilizing continuous-wave very-high-frequency communication and direction-finder equipment. By the use of the simplest form of range-finding circuit with a single modulation frequency chosen to give no range ambiguity up to 100 nautical miles, it would be reasonable to expect a probable error of one mile or less in the radial co-ordinate, assuming the circuit of the airborne communication equipment to be designed for high stability of phase shift at the modulation frequency of 809 cycles per second. The probable lateral error in position-finding, with the direction-finder used, is not likely to exceed 2.5 miles at a range of 100 nautical miles.

6. Acknowledgments

The use of the author's radial-trace bearing indicator as a time base to give a combined display of range and azimuth was the result of a suggestion by Mr. C. W. Earp, to whom thanks are also due for advice and criticism relating to circuit technique. The author wishes to express his appreciation of the co-operation of Mr. T. D. Gray, who carried out a large part of the experimental work. A number of other colleagues rendered valuable assistance, in particular Messrs. P. Sothcott, F. G. Cockerill and T. J. Cox.

The demonstration to the Provisional International Civil Aviation Organization delegations was made possible by the co-operation of the Ministry of Supply, whose help is gratefully acknowledged.

The photographs, Figs. 2 and 3, were taken during the Provisional International Civil Aviation Organization demonstrations at Farnborough and are reproduced by courtesy of the Controller of H.M. Stationery Office. Crown Copyright is reserved.

7. Appendix—Principle of the Linear Phase Shifter

The principle of the calibrated phase shifter used in the electronic cursor circuit (Section 4.2) is illustrated in Figs. 8(A) and 8(B). In Fig. 8(A), $AB \dots GH \dots$ represents a closed network of n equal uniform resistance elements arranged in one plane as a regular polygon with centre O . An n -phase generator is connected to the junction points of the network in progressive phase sequence, as indicated. OQP is a uniform resistive radial contact arm, grounded at O and capable of rotation about this point, making continuous contact with the network, compared with which its resistance is very high. The reference phase for the circuit is that at point A , and the angular position of the contact arm is θ , measured clockwise from OA .

Fig. 8(B) shows the relevant part of the vector diagram, in which Oa , Og , Oh , represent the voltages to ground at A , G and H . If Op is drawn to meet gh at p , and if $gp/gh = GP/GH$, then gp represents the voltage between G and P , and Op , the vector sum of Og and gp , represents the voltage to ground at the point of contact P . The phase of the voltage at this point is given by aOp and is clearly equal to θ , the angular position of the contact arm. By inspection of the diagrams, it will be seen that both the voltage between point P and ground, and the effective resistance of the contact arm, vary with θ according to the same law, and therefore the current through the contact arm is a constant. If the output voltage e is taken from a point Q on the arm, within the inscribed circle of the polygonal network, and if $OQ/OA = k$, it is clear that $e = kE/\theta$. The calibration of the

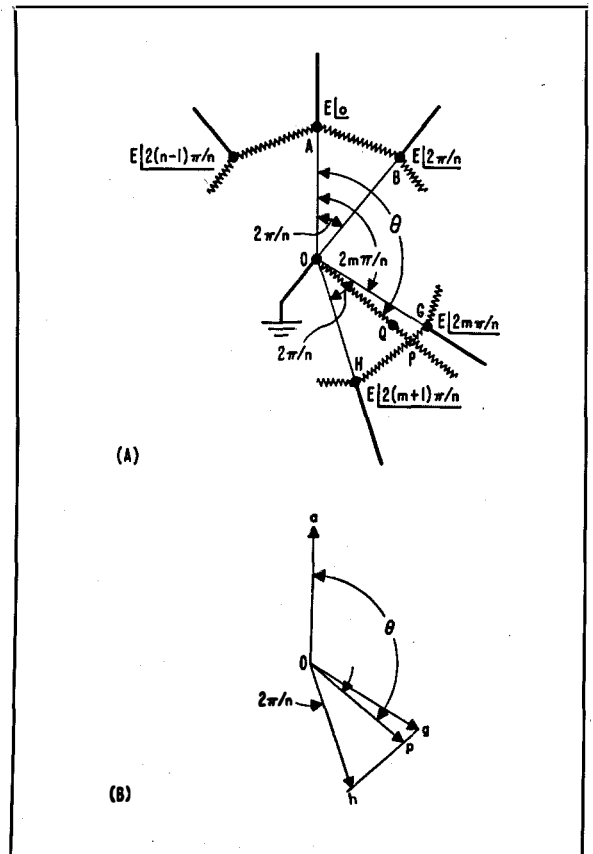

Fig. 8—Principle of linear phase shifter. (A) Polygonal arrangement of n resistance elements. (B) Vector diagram.

phase shifter is therefore uniform, and its output voltage is independent of phase angle.

The use of two resistive elements in rubbing contact is undesirable in a practical realization of the principle, and can be avoided very simply. In the experimental equipment described in the paper, $n=4$ and the network reduces physically to a square, with balanced voltages in quadrature applied between diagonally opposite points.

Design of an Ionization Manometer Tube*

By DAVID L. HOLLWAY

Standard Telephones and Cables Pty. Limited, Sydney, Australia

AN IONIZATION MANOMETER tube of new design is discussed, having a high sensitivity substantially independent of variations in the electrode potentials. The published measurements of efficiency of ionization are compared and used to predict the sensitivity of the gauge on different gases.

Curves of a function used in the calculation of the sensitivity are applicable to any design, and it is shown that secondary emission is an important factor in determining the slope of the anode characteristic.

Errors from leakage and photoelectric currents, gas take-up and gas heating are considered.

• • •

Just as in 1905, when the production of tantalum lamps required a sensitive vacuum meter, the metal-filament lamp became a Pirani Gauge,¹ so later the triode assisted in its own manufacture by becoming an ionization manometer.

The step of using the positive ion current flowing to the negative grid of an operating triode containing gas for the measurement of pressure is usually ascribed to Buckley² and Hausser, Ganschwindt and Rukop.³ Fogel,⁴ however, finds that it was described first by Baeyer.⁵ In addition to these originators, Dushman and Found⁶ in their 1921 study of the gauge state:

Some time ago Dr. Hull suggested to the writers that a gauge may be based on the measurement of the amount of positive ionization produced by the electron stream. After some preliminary experiments had been carried out with a gauge based on this suggestion, a paper on the same subject appeared by O. E. Buckley.

The gauge rapidly displaced Knudsen's absolute manometer and the molecular gauge of Langmuir in vacuum-tube manufacture, and has

* Published in abridged form in *Proceedings of the Institution of Radio Engineers* (Australia), v. 8, pp. 14-19; April, 1947, and pp. 4-10; May, 1947. This device is the subject of Australian Patent Application 6735, September 18, 1946.

¹ Numbered references will be found on page 385.

been used widely up to the present time. It is highly sensitive, simple, readily degassed and, at vacua better than 1 microbar, the ion current varies linearly with pressure. The variation in sensitivity between different gases will be discussed later. These advantages are attained fully only when the gauge tube is suitably designed, although most amplifying tubes will operate as pressure indicators.

The brief description in Table 1 does not do justice to the designs described in references 4 and 6. Characteristics other than *S*, *A* and *C* are important.

1. Development

Early during 1946, it became necessary to design a gauge tube to replace the triode type 4101 (Fig. 1), which previously was used as a manometer in the manufacture of transmitting valves. The electrode system resembles that described by Jaycox⁸ (Table 1) and the sensitivity is com-

paratively high. To suit existing equipment, the same or a higher sensitivity was required in the new design. Also, it was hoped to achieve this with a much less expensive construction. At first, several simple assemblies were tried. These were tested by comparison with a known manometer by sealing all tubes to a short large-diameter header connected by a length of small tube to a normal pumping system consisting of liquid-air trap, mercury-diffusion and

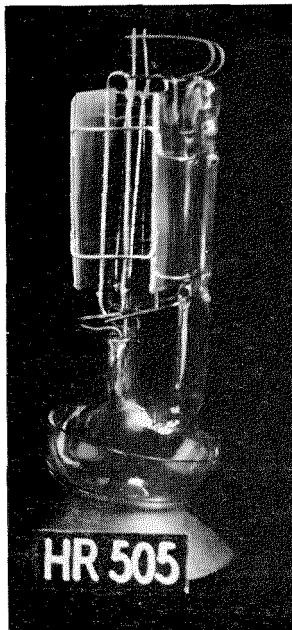

Fig. 1—Electrode system of the 4101 triode.

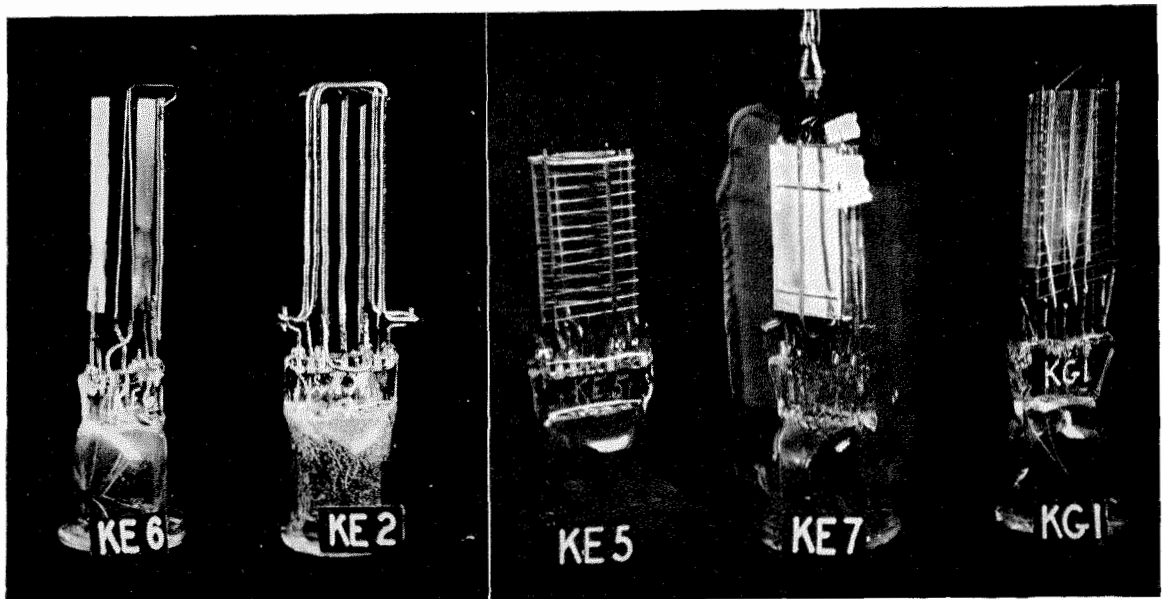

Fig. 2—Experimental manometer designs. At 125 volts anode potential, the measured sensitivities were: KE6 with strip electrodes, $S=1.7$; KE5 with aligned plane grids, inner positive, $S=0.35$, outer positive, $S=3.7$; KE7, plane triode with grid positive, $S=3.0$; KG1 with plane grid, plane plate, and central filament, grid positive, $S=3.2$, plate positive, $S=1.2$.

backing pumps. After an oven bake of one hour and general degassing, gas was released in the two manometer equipments of the electronic

header and simultaneous readings were taken on control type. Some of the first experimental designs are shown with characteristics in Fig. 2. These were difficult to degas electronically and were insensitive.

Consideration of the reasons for their failure suggested the single-sided design (KF1, Fig. 3) having a curved reflector which was more successful ($S=6.3$). Moreover, on electron bombardment it degassed readily.*

* If the area of the electrodes is too large, it is difficult to bring them to red heat by electron bombardment without exceeding a safe filament emission because gas pressures of around 0.5 microbar may limit diode voltage drop to 20–40 volts. If the area is too small, on bombardment the bulb may not be warmed sufficiently above its normal operating temperature in applications where no oven bake is possible.

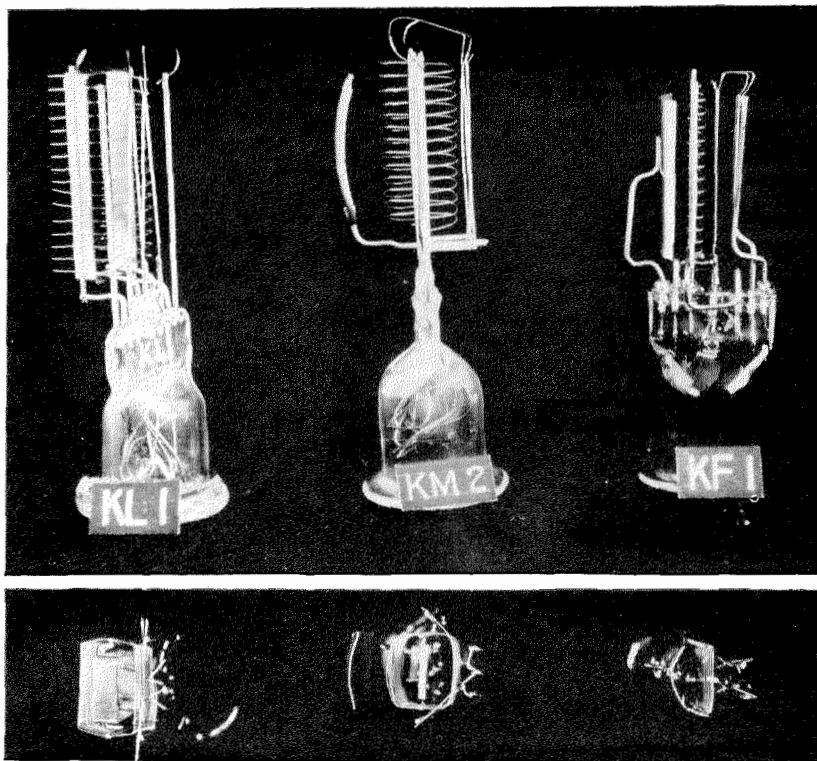

Fig. 3—Designs having higher sensitivities than those shown in Fig. 2.

1.1 "LONG-PATH" DESIGN

KL1, shown in Fig. 3, represents an entirely different construction in which a rectangular nickel frame (collector) is surrounded by a positive grid. The objective here is to keep the electrons, over their whole path through the grid, near the velocity at which maximum ionization takes place. For these tubes, with a grid 0.45 inch wide, S reached 14 and this principle

was adopted in all later tubes. While the optimum proportions for this design were being sought, it was found that under some conditions of bombardment, with comparatively high gas pressure, local heating produced in the glass wall could produce cracks. This trouble is caused when the secondary emission coefficient of the glass wall exceeds unity; allowing the surface to rise to some positive potential. The

TABLE 1
PUBLISHED INFORMATION ON IONIZATION-MANOMETER DESIGN

Described By	Construction	Design Features	Sensitivity S^*	Anode Characteristic A^\dagger	Collector Characteristic C^\ddagger
Buckley ² 1916	Three Vee filaments in parallel planes 5 millimetres apart; collector central.	Electrodes may be degassed by conduction. (First published description of an ionization gauge.)	1.33	—	—
Dushman and Found ⁶ 1921	Molybdenum cylinder 12 millimetres long, 12 millimetres in diameter (collector), with coaxial 3-turn helix of 0.125-millimetre tungsten, 3.65 millimetres inside diameter (anode). Filament, 5 turns 0.125-millimetre tungsten, 2.25 millimetres in diameter; collector carried on separate press.	May be degassed thoroughly by high-frequency or electronic bombardment. Low electrical leakage to collector; linear; shielded from charge variations on glass wall.	3.9 (250 volts)	1.17	Within 2 per cent of unity
Reynolds ⁷ 1931	As above but cylinder collector 13 millimetres in diameter, 16 millimetres long.	Experimental gauges.	4.4 (250 volts)	1.17	—
	Triode of UV200 construction having a flat plate and hairpin filament	Experimental gauges.	4.2 (125 volts)	1.06	—
Pirani ¹	Telefunken N91A valve as manometer	No details	2.4 (110 volts)	—	—
Jaycox and Weinhart ⁸ 1931	Plane triode. Oxide filament, grid of 0.010-inch nickel wires; 2 collector plates $1\frac{1}{4}$ by $\frac{3}{4}$ inches, $\frac{1}{4}$ inch from filament.	Readily degassed by electronic bombardment; high collector insulation; shielded; linear; etc.	7.5 (125 volts)	1.7	1.03
	With constructional features to reduce leakage.		13 (200 volts)	—	—
Maloff and Epstein ⁹ 1938	210-type plane triode; grid positive.	—	2.7 (110 volts)	—	—
Montgomery and Montgomery ¹⁰ 1938	247 pentode, grid controlled; screen + plate — collector.	Simple control of electron current.	25 \ddagger (180 volts)	1.17	—
Fogel ⁴ 1946	Two parallel plates; 1 collector; 1 anode $1\frac{1}{2}$ inches by $\frac{3}{4}$ inch, spaced $\frac{9}{16}$ inch apart with a central Vee filament. Mounted on single press but with vapour shield to prevent leakage.	Readily degassed by electronic bombardment or high-frequency; linear; high collector insulation; designed for mass production.	3.75 (200 volts)	1.13	—

* S is measured in microamperes of positive ion current per milliampere of electron current per microbar gas pressure. (1 microbar = 1/1333 millimetre of mercury.) The tabulated sensitivities refer to argon or air.

[†] See first paragraph of Section 2.

[‡] Because this sensitivity appeared to be high, a copy of the circuit was set up during the present investigation. For the 247 tube tested, $S=2.6$ to 3.5 referred to argon.

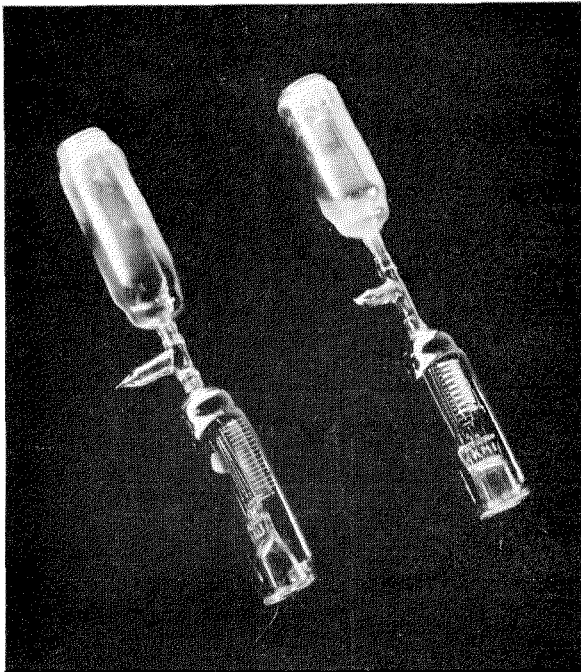

Fig. 4—Sealed-off systems for measurement of manometer characteristics by the mercury-vapour method.

reflector shown in KM2 removes this danger. Tubes of this general design were quite sensitive ($S=18$) and otherwise had good characteristics.

A mercury-vapour method of checking the sensitivities was used in place of the comparison method for most of the tests. Preliminary work showed that reliable results could be obtained from sealed-off tubes containing mercury if double bulbs (Fig. 4) were made up. The second bulb contains a nickel flag enclosing a glass-sealed mercury pill and also a barium getter. After oven bake and normal degassing, the flags are fired and the whole tube again degassed before sealing off. On test, the mercury bulb, neck and part of the manometer are immersed in a thermos of water near zero degrees centigrade. After a short bombardment to clear the electrodes of mercury, the water is stirred and water temperature and ion current readings are taken. Most of the tests were made at a temperature-limited electron current of 200 microamperes but with additional readings at 50, 2000 and 10,000 microamperes to check linearity. The temperature is raised in steps by adding hot water and stirring. Later on, a single large bulb was used for measurements by the same method.

Because the anode current includes the electrons released from ions in addition to the filament emission, for gas pressures at which the ion current is not negligible, it is necessary to choose between constant anode current and constant filament emission. In all tests, the electronic control was set to keep the emission constant. For example, the 71-degree Fahrenheit reading (Table 2) corresponds to an anode current of 210 microamperes. This was considered to be the better alternative because the ejected electrons have a low velocity over most of their path.

The last column of Table 2 gives the mercury sensitivity that must be divided by two for comparison with argon sensitivities quoted earlier.

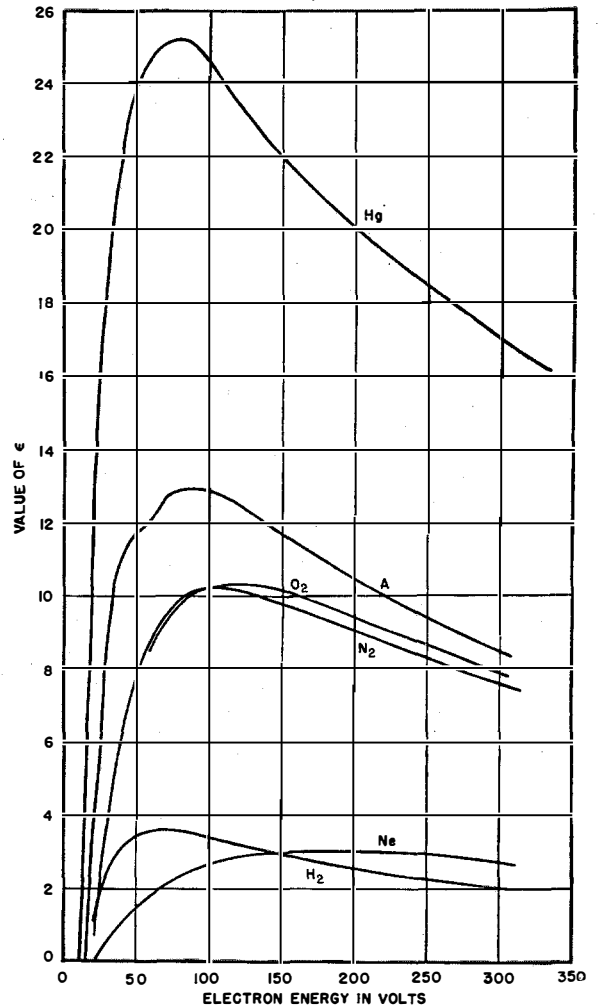

Fig. 5—The efficiency of ionization ϵ of several gases as a function of electron energy. See Table 2.

2. Prediction of Electrical Characteristics by Analysis

Any ionization manometer has the following directly measurable electrical characteristics.

A. Sensitivity *S* in microamperes per milliampere microbar.

B. Anode characteristic, or variation in *S* with positive electrode voltage. For simplicity this is specified as *A*, where

$$A = \frac{S \text{ at } +200 \text{ volts on anode}}{S \text{ at } +150 \text{ volts on anode}}$$

Because this will vary a little between different gases, all calculated ratios refer to mercury vapour.

C. Negative-collector characteristic. This will be defined similarly as the ratio *C*, where

$$C = \frac{S \text{ at } -20 \text{ volts}}{S \text{ at } -15 \text{ volts}}$$

A design objective should be to reduce these ratios as nearly as possible to unity to allow the use of unstabilized voltage supplies. Also, when *C*=1, *S* will not change if a high resistance is inserted in the collector lead to provide a drive of several volts for an electron-tube microammeter.

The basic information needed in the calculation of the sensitivity of a particular structure is

the number of positive charges freed by ionization per electron centimetre of path. This quantity is referred to in the literature as the "efficiency of ionization" as distinct from the "probability of ionization," which indicates the number of ions, whether singly, doubly or multiply charged.¹¹

TABLE 2

TEST ON KL3 (EXPERIMENTAL DESIGN)
BY MERCURY-VAPOUR METHOD

Grid Voltage = +125; Collector = -20.

Temperature ° Fahrenheit	Micro-amperes Ion Current for 200 Micro-amperes to Grid	Vapour Pressure in Micro-bars	Apparent Sensitivity <i>S'</i>	Thermal Effusion Correction Factor $\left(\frac{460+71}{460+T}\right)^{\frac{1}{2}}$	True Sensitivity <i>S'</i> × Factor
32(?)	1.45	0.246	29.4	1.041	30.6
38.5	1.97	0.352	28.0	1.033	28.9
41	2.25	0.40	28.1	1.031	29.0
45	2.80	0.495	28.3	1.027	29.1
48.5	3.30	0.601	27.5	1.023	28.2
50.8	3.72	0.683	27.2	1.021	27.8
55	4.69	0.840	27.9	1.017	28.4
59.5	5.88	1.06	27.8	1.012	28.1
62.8	7.02	1.23	28.5	1.010	28.8
67.6	8.80	1.58	27.9	1.008	28.0
69.5	9.68	1.70	28.5	—	28.5
71	10.40	1.84	28.3	—	28.3

TABLE 3

EFFICIENCIES OF IONIZATION

ε = Number of Positive Charges Freed per Centimetre of Electron Path Referred to 1 Millimetre Pressure at 0 Degrees Centigrade

Gas	Observer	Electron Voltage					
		50	100	150	200	250	300
Hg	Jones ¹⁷	23.5	25.5	24	22.5	20.9	19.1
	Bleakney ¹⁸	23.6	24.8	21.8	20.4	18.5	17.1
	Compton and Van Voorhis ¹⁹	21.3	23.1	23	22.5	21.8	21
	Smith ¹²	17.9	19.25	18.15	16.9	15.7	14.6
	Nottingham ²⁸	19.0	14.8	—	—	—	—
A	Smith ²¹	11.68	12.9	11.83	10.53	9.43	8.58
	Bleakney ²³	11.8	12.9	11.7	10.5	9.2	8.4
	Compton and Van Voorhis ¹⁹	10.0	12.2	12.3	11.8	11.2	10.5
CO	Tate and Smith ²⁴	9.02	10.9	10.25	9.28	8.4	7.65
N ₂	Tate and Smith ²⁴	7.88	10.25	9.81	9.0	8.26	7.55
	Compton and Van Voorhis ¹⁹	7.7	11	11.7	11.8	11.5	11
He	Smith ²¹	0.86	1.24	1.23	1.15	1.06	0.97
	Compton and Van Voorhis ¹⁹	1.0	1.7	1.9	2	1.9	1.9
H ₂	Tate and Smith ²⁴	3.45	3.4	2.94	2.58	2.28	2.03
	Compton and Van Voorhis ¹⁹	3.6	4.1	4.1	4.0	3.8	3.5
Ne	Smith ²¹	1.47	2.66	2.99	2.99	2.87	2.31
	Bleakney ²³	1.45	2.7	3.0	3.0	2.9	2.7
	Compton and Van Voorhis ¹⁹	1.1	2.5	3.3	3.5	3.6	3.8

The efficiency of ionization ϵ may be defined as the number of charges produced per electron centimetre of path in the gas specified, referred to zero degrees centigrade and 1 millimetre pressure. Fig. 5 shows the variation in ϵ as a function of electron voltage for several gases, while Table 3 provides similar information as derived from the literature.

In the method following, the tube to be analysed is split up into a number of sections, perpendicular to the electron flow, chosen so that the voltage gradient may be considered constant over the distance between sections. Space-charge distortion of the static fields is neglected (all the manometers considered use a temperature-limited electron current) and the tubes are assumed to be operating in the low-pressure linear region where only a small proportion of the electrons produce ions.

Consider an electron stream of i_e milliamperes moving between parallel equipotential planes l_2 centimetres apart along a normal path.

Let $E_1, E_2 =$ the potentials of these planes measured in volts above the emitting filament.

$G_{1,2} =$ potential gradient, the planes being chosen so that $G_{1,2}$ may be assumed constant.

$$G_{1,2} = \frac{E_2 - E_1}{l_2} \text{ volts centimetres}^{-1}.$$

$i_p =$ total positive ion current in microamperes produced over this path.

$\phi_{1,2} =$ the fraction of positive charges collected by the negative measuring electrode.

$S_{1,2} =$ the component of sensitivity contributed by the element 1,2.

$= \phi_{1,2} i_p / i_e$ when the bulb contains mercury vapour at 1 microbar pressure at 20 degrees centigrade.

Now because the electrons and single ions are of equal but opposite charge,

$$i_p = \frac{1000}{1333} i_e \int_0^{l_2} \epsilon dl,$$

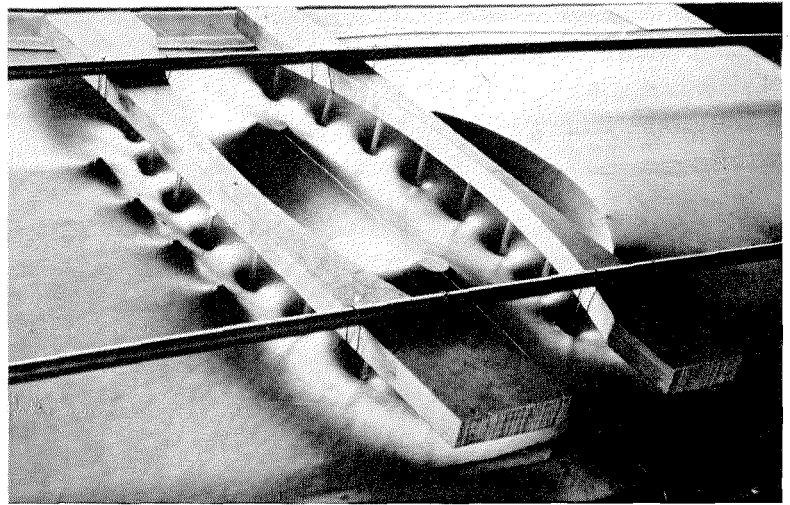

Fig. 6—Rubber-table model of a structure similar to KM2 of Fig. 3. The filaments appear on the left side and the collector on the right.

whence

$$S_{1,2} = \frac{\phi_{1,2}}{1.333 G_{1,2}} \int_{E_1}^{E_2} \epsilon dE. \quad (1)$$

The sensitivity S of the structure is then

$$S = S_{0,1} + S_{1,2} + S_{2,3} + \dots$$

$$\text{microamperes milliamperes}^{-1} \text{ microbars}^{-1}. \quad (2)$$

For numerical calculation, since ϵ is not a simply specified function of E , the integrations are performed graphically.

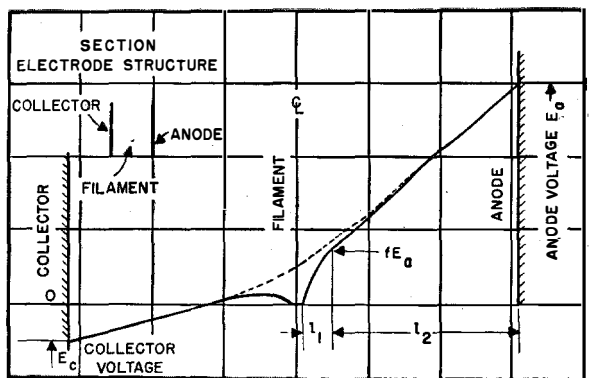

Fig. 7—Potential diagram for a plane plate structure. The dotted line represents the potential between filament strands; the full line indicates the potential in a plane containing the filament.

Evidently, a knowledge of the fields within the electrodes is necessary. These can be calculated from the dimensions only for simple structures, but approximations can be determined by

the use of a rubber table model* with the practical advantage that results of changes in the arrangement of electrodes can be judged after some experimentation. A horizontal cross-section of KM2 (Fig. 3) is shown in model form in Fig. 6. Positive electrodes project downwards into the sheet and negative upwards. The grid crosswires are turned vertically in the model following the practice used in calculating triode characteristics by conformal transformation.¹⁴

2.1 CALCULATION OF S AND A FOR A PLANE PLATE STRUCTURE

The potential diagram and arrangement of electrodes is shown in Fig. 7.

Let $E_a = E_2$ = potential of the anode plate (volts).
 $fE_2 = E_1$ = potential at distance l_1 centimetres along the electron path to the anode.

* Fremlin¹³ shows applications of this method in the design of amplifying tubes.

The distance l_1 is chosen from the rubber model, or calculated distribution, so that the gradients fE_2/l_1 and $E_2(1-f)/l_2$ may be assumed constant.

From (1),

$$1.33S = \phi_{0,1} \frac{l_1}{fE_2} \int_0^{fE_2} \epsilon dE + \phi_{1,2} \frac{l_2}{(1-f)E_2} \int_{fE_2}^{E_2} \epsilon dE$$

$$= \phi_{0,1} l_{1(0, E_1)} + \phi_{1,2} l_2 Q_{(fE_2, E_2)} \tag{3}$$

This expression,

$$Q_{(fE_2, E_2)} = \frac{1}{(1-f)E_2} \int_{fE_2}^{E_2} \epsilon dE$$

appears in all manometer calculations so that it is worthwhile to provide reference values in a graphical form (Fig. 8). These are calculated from the results of Bleakney¹⁸ and Jones¹⁷ given after Table 4, but referred to room temperature. $Q_{(fE_2, E_2)}$ represents simply the charges per

TABLE 4
 VALUE OF $0.01 \int_0^E \epsilon dE$
 at 0 Degrees Centigrade and 1 Millimetre Pressure

Gas	Observer	Voltage E					
		50	100	150	200	250	300
Hg	Jones ¹⁷	7.0	19.1	31.7	43.6	54.2	64.2
	Bleakney ¹⁸	6.36	18.8	30.3	40.8	50.4	59.3
	Compton and Van Voohris ¹⁹	5.3	16.7	28.3	39.7	50.8	61.4
	Smith ²²	4.74	14.3	23.6	32.4	40.5	48.1
A	Smith ²¹	2.8	9.1	15.3	20.9	25.8	30.3
	Bleakney ²³	2.8	9.15	15.3	20.85	25.75	30.15
	Compton and Van Voohris ¹⁹	2.0	7.8	13.9	20	25.8	30.2
CO	Tate and Smith ²⁴	1.9	7.1	12.4	17.3	21.7	25.7
N ₂	Smith ²¹	1.4	6.2	11.2	15.9	20.2	24.3
	Compton and Van Voohris ¹⁹	1.3	6.3	12	17.9	23.7	30.5
O ₂	Tate and Smith ²⁴	1.54	6.26	11.4	16.3	20.8	24.9
Ne	Smith ²¹	0.22	1.31	2.74	4.24	5.7	6.9
	Bleakney ²³	0.27	1.34	2.78	4.28	5.8	7.2
	Compton and Van Voohris ¹⁹	0.16	1.15	2.56	4.25	6.05	0.9
He	Smith ²¹	0.13	0.68	1.31	1.90	2.46	2.97
	Compton and Van Voohris ¹⁹	0.14	0.85	1.78	2.76	3.74	4.74
H ₂	Tate and Smith ²⁴	0.80	2.57	4.14	5.52	6.73	7.79
	Compton and Van Voohris ¹⁹	0.70	2.66	2.74	6.78	8.75	10.5

AVERAGE VALUES OF THE INTEGRAL USED IN ALL CALCULATIONS
 20 Degrees Centigrade, 1 Millimetre of Mercury, from References 12, 17 and 18

Volts	30	35	40	50	60	70	80	90	100	125	150	200	250	300
$0.01 \int_0^E \epsilon dE$	1.83	2.73	3.72	5.85	8.12	10.5	12.8	15.3	17.6	23.5	29.2	40.0	50.1	59.4

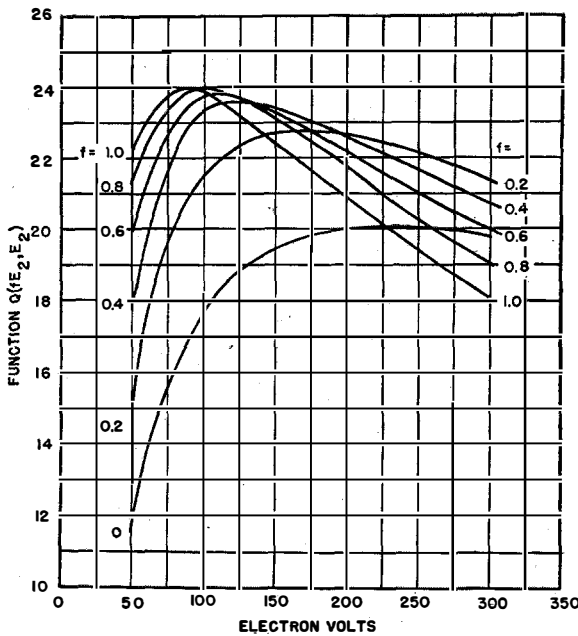

Fig. 8—Reference values for

$$\frac{1}{E_2(1-f)} \int_{fE_2}^{E_2} \epsilon dE = Q(fE_2, E_2)$$

for mercury vapour at 20 degrees centigrade.

electron moving between fE_2 and E_2 over a path 1 centimetre long. When $f=1$, the expression becomes $Q = \epsilon$. It will be noted that $Q_{(0, E_1)}$ can be obtained from the curve $f=0$ (Fig. 8). The fractions of ions collected, $\phi_{0, 1}$ and $\phi_{1, 2}$, are difficult to estimate, but in judging their values it may be noted that in the pressure range considered, before ionization, gas molecules pass freely through the structure rebounding from plates and bulb walls with few collisions between molecules. The average particle energy corresponds to a fraction of an electron volt. Once ionized in the interelectrode space, however, the positive particle is subject to an electrostatic force in a direction opposite to the positive potential gradient. Its final translational energy on reaching the collector will be the collector potential $|E_c| + E$, where E volts above the cathode corresponds to the point at which ionization occurred. Because $|E_c| + E$ will always exceed, say, 20 volts and may average 70 volts or more, and also because a negligibly small proportion of ions recombine except on striking the bulb or collector, the thermal motions have only a small effect, and the ion path could be approximated by ball bearings released from

rest at different points along the electron paths on an inverted rubber table model. The bulb walls assume a negative charge under running conditions which means that a proportion could escape around the collector plate of this design.

Fig. 9 compares the measured anode characteristic with that calculated from (3) for $\phi_{0, 1} = \phi_{1, 2} = 1$. The curves suggest that these constants are near $\frac{1}{2}$. Note the improved agreement in slope when the secondary-emission term is included.

2.2 CHARACTERISTICS OF "LONG-PATH" DESIGN

Fig. 10 is the potential curve for an experimental tube resembling KM2 (Fig. 3). Emitted electrons leave the filament, pass through the sides of the anode, are slowed and returned by the reflector. When the filament plane is reached, those travelling perpendicularly will pass through at low velocity but a proportion deflected to have a velocity component parallel to the filament plane equivalent to the potential "hump" between filament strands, will be reflected and possibly make a second transit of the grid space.

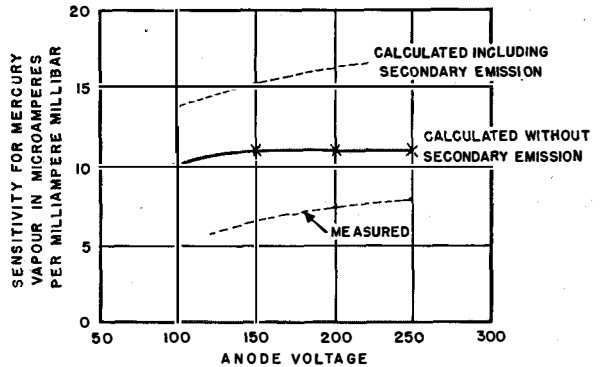

Fig. 9—Calculated and measured anode characteristics of the plane plate structure of Fig. 7. In the calculated curves, ϕ is taken as unity, which is its greatest possible value.

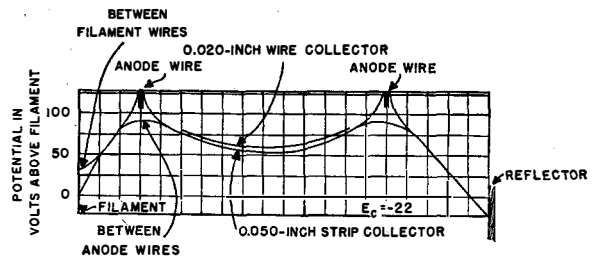

Fig. 10—Potential-distribution curves in a tube of the "long-path" design for two different central collectors. Structures are similar to KM1 and KM2.

By a further approximation, now define the ratio θ as

θ = fraction of the electron stream that passes through one of the grid planes. The fraction $(1 - \theta)$ is intercepted.*

Measurements of θ^2 through both planes of a grid similar to that used on KM2 (10.2 turns per inch of 0.008-inch wire) gave $\theta = 0.80$. So that if a second reflector were placed near the filament plane, it would not produce a sufficient gain in sensitivity to justify the complication.

Where l = distance in centimetres between grid planes,

d = distance in centimetres to zero potential plane, just off the reflector,

E_a = applied anode voltage in volts,

E_2 = average potential of electrons passing between grid wires in volts. It is assumed to be equal to the potential midway between the wires.

$E_2/E_a \approx 0.9$, usually, in these tubes,

ϕ_g, ϕ_r = fractions of ion current collected in grid and reflector spaces respectively,

then the expression for the sensitivity is

$$1.33S = \phi_g(\theta + \theta^3) \frac{l}{(1-f)E_2} \int_{fE_2}^{E_2} \epsilon dE + \phi_r 2\theta^2 \frac{d}{E_2} \int_0^{E_2} \epsilon dE. \quad (4)$$

Experimental models made with identical constructions but with collectors of decreasing diameter of wire show that ϕ_g remains near unity until 0.02-inch diameter wire is reached. Because the ionizing space is entirely surrounded by a positive electrode, ϕ_g may be set = 1. When d is not too great, also $\phi_r \approx 1$.

It is an objective to bring A near unity. From an inspection of (4) and Fig. 8, this would seem to be merely a matter of choosing the ratio l/d so that the slopes of the two terms of (4) cancel. But, in fact, secondary emission is an important factor in determining the slope.

2.3 SECONDARY-EMISSION CORRECTION

When electrons (of energy E_a) reach the grid, a small proportion is reflected directly (these are

* These electrodes resemble grids in construction (see Figs. 3, 6 and 14), but they are always at a positive potential (anodes) in this design.

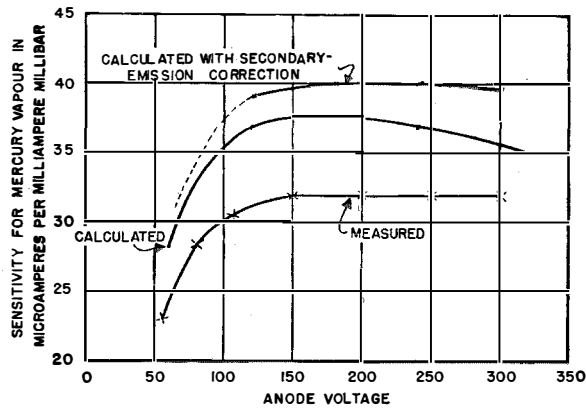

Fig. 11—Calculated and measured anode characteristics of a “long-path” design, KM1. Note that inclusion of the secondary-emission term improves the agreement between the slopes of the characteristics. If the mercury results of Smith¹² are used instead of Jones,¹⁷ the curves agree in magnitude.

neglected) and others are emitted at all energies between 0 and E_a . A step-by-step procedure is used to estimate the secondary-emission correction, the distribution of energy relation being based on Rudberg’s¹⁵ curves, which check roughly with that given by Harries¹⁶ as an average.

If s = secondary emission coefficient at the anode voltage E_a ,

k = a fraction of i_e the electron current,

m = a fraction of E_a ,

the chosen energy distribution may be represented by the approximation:

Step	1	2	3	4
Current k	0.5	0.22	0.19	0.09
Voltage m	0.1	0.3	0.66	0.93

$k_1 + k_2 + k_3 + k_4 = 1$ and the secondary coefficient s applying to the incident voltage must be included. From $\theta = 0.8$, the fraction $\theta - \theta^3 = 0.29$ arrives at the back grid and an almost equal current at the front. Consider only the back grid. Now, when $m < (1 - f)$ secondary electrons do not pass the potential minimum, so that the first steps add $\Delta_1 S, \Delta_2 S$, etc., to the sensitivities where

$$1.33\Delta S \approx \frac{0.3sk}{(1-\theta^2)} \left[\frac{l}{(1-f)E_2} + \frac{2d}{E_2} \right] \int_0^{mE_a} \epsilon dE \quad (5)$$

$$\approx \frac{0.3msk}{(1-\theta^2)} \left[\frac{l}{(1-f)} + 2d \right] \frac{1}{mE_2} \int_0^{mE_2} \epsilon dE. \quad (6)$$

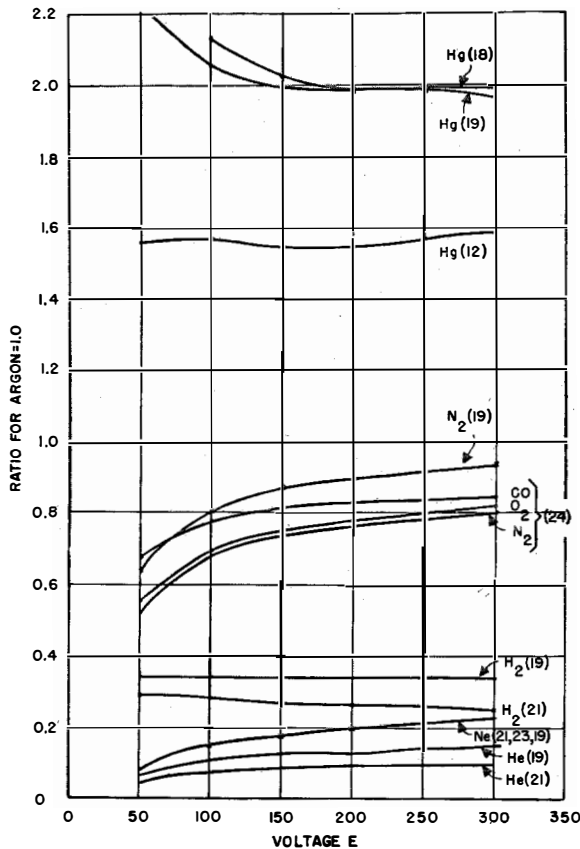

Fig. 12—Probable sensitivity ratios for different gases, plotted from Table 5. Source references are indicated in parentheses.

(The $\frac{1}{1-\theta^2}$ is inserted to sum all the oscillations.) Electrons ejected by the secondaries are neglected. For terms in which $m > (1-f)$, the k component for the fourth step may be inserted in the expression,

$$1.33\Delta_4 S \approx 0.3k_s \times \left[\frac{l\theta}{(1-f)E_2} \int_{(m+f-1)E_2}^{mE_2} \epsilon dE + \frac{2dm}{E_2} \int_0^{mE_2} \epsilon dE \right]$$

Clearly there are approximations in this, only allowable because ΔS is a small correction term.

3. Sensitivity on Different Gases

The sensitivity S , defined earlier, varies markedly from gas to gas. A group of ratios of $\frac{S \text{ for gas}}{S \text{ for argon}}$ strictly speaking apply only to one gauge and one anode voltage. The chief gauge characteristics that could cause variation in the ratios are the relative lengths of electron path

at high and low energies. For example, if a manometer includes only constant gradients from the anode voltage to zero and secondary emission is neglected, its indications on different gases should correspond with the curves plotted in Fig. 8. Note also that it will have an anode characteristic (on mercury vapour) following curve $f=0$ (Fig. 8), with an additional "rise" (3 per cent between 150 and 200 volts, collector at -15 volts) contributed by the movement of d , the distance to the zero-potential point, outward towards the reflector, if a reflector is used. There is, in fact, a connection between the anode characteristic and the gas ratios for usual designs. Fig. 12 shows that the mercury/argon ratio rises sharply at low voltages.

From this it may be expected that tubes having a greater proportion of low-voltage path than the linear type and/or appreciable secondary emission, would exhibit both a sharply rising anode characteristic and a high mercury/argon ratio. The available evidence supports this although Dushman and Young²⁵ give a higher ratio (2.73, 2.75 mercury/argon on a cylindrical structure) than can be attributed to this. The converse argument refers more directly to the present design; that is, a tube having an anode characteristic resembling $f=0$ (Fig. 8) should vary in sensitivity between different gases in the ratio of the integrals given in Table 4.

Fig. 12 (from Table 5) shows this ratio as a fraction of anode voltage for several gases. Thus, when the composition of the gas being measured is known, the sensitivity of this design may be predicted from its mercury or argon value by

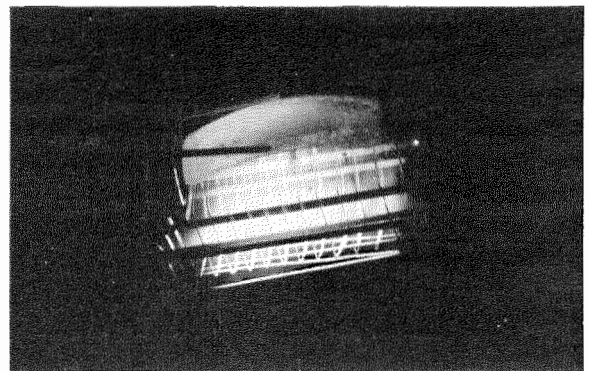

Fig. 13—An electrode system being degassed by electronic bombardment, photographed by its own light. At this temperature, gas is released rapidly.

reference to Fig. 12. A survey of the literature showed that the experimental technique used in the measurement of the efficiency of ionization was improved considerably by Jones¹⁷ and later workers. The results shown in Table 1 were taken from published curves and arranged in an order of preference. Because most of the experimental errors diminish in the calculation of integral ratios, some earlier work is included in Table 5.

4. Usefulness and Limitations of the Design

Ionization gauges have been rejected by some workers requiring high accuracy because of the comparatively high rate of gas takeup found in the models used. (See Pirani.¹) There appear to be several different mechanisms of takeup, which

must be considered separately. Apparently, they are:

A. An extremely rapid removal of any gas, found whenever an electrode or the filament reaches a temperature at which its metal has significant vapour pressure. For example, it was found that if the present tube were over-run on bombardment to 28 watts input, a 3-litre tube containing air at 300 microbars was reduced to 0.2 microbar in 30 minutes. A slight dark deposit of nickel appears on the inside of the bulb under these conditions. After metal has been distilled over and the tube switched off, takeup continues for a time but at (in one test) $\frac{1}{4}$ th the rate. This method of takeup is an advantage rather than a disadvantage for any application, and applies only to bombardment conditions.

B. There is a slow takeup during operation which depends (probably) on the filament temperature. Takeup of air is found when a tungsten filament is run at near 1300

TABLE 5

$$\text{VALUE OF } \int_0^E \epsilon_{\text{gas}} dE / \int_0^E \epsilon_{\text{argon}} dE$$

Ratio of Positive Ion Current in the Gas Indicated to the Current in Argon at the Same Pressure for Manometer Tubes Having Approximately Linear Voltage Gradients from *E* to 0.

Gas	Observer	Voltage <i>E</i>					
		50	100	150	200	250	300
Hg	Bleakney ¹⁸	2.23	2.05	2.0	1.95	1.96	1.97
	Compton and Van Voohris ¹⁹	2.6	2.13	2.03	1.99	1.97	1.97
	Dushman and Young ²⁵	—	2.73	—	—	—	—
	Smith ¹²	1.7	1.6	1.54	1.55	1.57	1.58
A	All Observers	1	1	1	1	1	1
CO	Tate and Smith ²⁴	0.7	0.78	0.81	0.83	0.84	0.85
	Dushman and Found ⁶	—	0.81	—	—	—	—
N ₂	Smith ²¹	0.52	0.68	0.73	0.76	0.78	0.80
	Compton and Van Voohris ¹⁹	0.64	0.80	0.87	0.87	0.92	0.94
	Hughes and Klein ²²	—	0.9	0.95	0.97	0.97	0.98
	Dushman and Found ⁶	—	0.88	—	—	—	—
	Dushman and Found ²⁵	—	0.89	—	—	—	—
O ₂	Tate and Smith ²⁴	0.56	0.69	0.74	0.78	0.80	0.82
Ne	Smith ²¹	0.08	0.14	0.18	0.20	0.22	0.23
	Bleakney ²³	0.09	0.146	0.18	0.20	0.224	0.24
	Compton and Van Voohris ¹⁹	0.08	0.15	0.18	0.21	0.23	0.25
	Hughes and Klein ²²	0.07	0.14	0.185	0.21	—	0.242
	Dushman and Young ²⁵	—	0.196	—	—	—	—
He	Smith ²¹	0.045	0.075	0.085	0.091	0.095	0.097
	Compton and Van Voohris ¹⁹	0.07	0.11	0.13	0.14	0.145	0.15
	Hughes and Klein ²²	0.06	0.09	0.10	0.11	—	0.12
	Dushman and Young ²⁵	—	0.14	—	—	—	—
H ₂	Smith ²¹	0.29	0.28	0.27	0.264	0.261	0.257
	Compton and Van Voohris ¹⁹	0.34	0.34	0.34	0.339	0.339	0.338
	Hughes and Klein ²²	0.19	0.28	0.30	0.30	—	0.30
	Dushman and Young ²⁵	—	0.39	—	—	—	—

Observations from references 6 and 25 are from experimental measurements on manometers. Strictly speaking, they are not comparable and are included only for general comparison. Nonlinearity, secondary emission and the other factors discussed earlier may account for the difference, although the argon measurement of reference 25 appears to include most of the discrepancy.

degrees centigrade. An oxide-coated-filament tube showed rates of

- 17 milliamperes—0.6 cubic centimetres per second
- 8.6 milliamperes—0.3 cubic centimetres per second
- 0.4 milliamperes—0.1–0.2 cubic centimetres per second

(pressure approximately 0.1 microbar) for an almost worn-out manometer having a fairly bright filament; a new tube would probably be lower.

C. Blears²⁷ notes that in the measurement of an organic vapour, a 0.7-litre-per-second tubulation gave approximately 1/10th the pressure reading of an 83-litre-per-second connection. It is thought that the filament temperature would be important in determining this rate and similar tests may be made later with the present oxide filament, which runs "black" when the electron current is reduced to 200 microamperes.

5. Gas Heating

For precise measurements, a small correction must be made for gas heating.²⁶ For tubes running at low electron currents, the openness of the structure (Fig. 14) suggests that the bulb wall temperature may be taken as the gas temperature with little error.

6. Insulation and Photoelectric Currents

Simplicity of manufacture required that all elements should mount from the press. Two precautions have been taken to reduce electrical leakage:

- A. The collector leads pass through glass sleeves projecting internally and externally.
- B. The high potential anode is separated by the (low-potential) filament leads from the collector so that a slight "guard ring" protection is obtained.

Insulation resistance measurements made between collector and all other electrodes for tubes after overrunning on bombardment (darkened bulbs) give values of 2×10^{10} ohms and for new tubes, 5×10^{10} ohms. Photoelectric currents are greater than leakage currents in bright daylight, and for most precise work the bulb should be screened from light and the filament kept cool by running at a low electron current.

7. Sensitivity

"Long-path" designs similar to KM2 have good electrical characteristics. But a drawback is the close spacing needed between the collector loop inside the grid and the grid sidewires, to

keep the fraction f above 0.6. This complicates the assembly operation and makes the structure sensitive to bumps and vibration.

A satisfactory solution is the replacement of the central collector frame by a "virtual collector." This consists of a pair of openings cut in the back surface of the grid as shown in Fig. 14. Ions are accelerated towards these openings from almost all points in the grid space. With this construction, f may be set at any value by the adjustment of the sizes of the grid openings. It is then comparatively easy to set f and d so that the anode characteristic A is unity. Also, the structure has only 3 simple electrodes: filament, grid and reflector (collector), with no critical spacings.

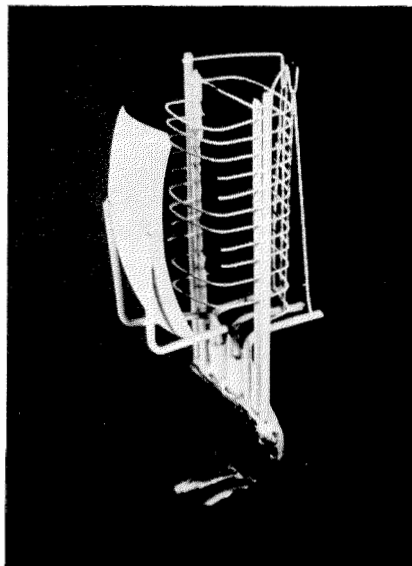

Fig. 14—The electrode system of the simplified design. The central frame seen in KM2 of Figs. 3 and 6 has been replaced by a pair of openings in the grid.

For the dimensions tentatively adopted, tests on experimental tubes show

$$S(\text{argon}) = 15 \text{ microamperes per milliampere microbar}$$

for voltages between 125 and 200. For other gases, the curves shown in Fig. 12 may be used to increase or decrease this figure. The value of A varies with the type of gas, but for mercury or air in the linear range, A is within 3 per cent of unity and C is within 1 per cent of unity.

8. Linearity at High Gas Pressures

Tests were made to find the high-pressure limit of linear operation on several experimental designs. These confirmed Dushman's tests, showing that the high pressure range is extended considerably by the use of low anode currents. At 200 microamperes electron current, a high limit was found for mercury vapour at 1.8 microbars. At this pressure, when the anode voltage was increased above 180, the sensitivity dropped suddenly to nearly one half. On reducing the anode voltage, the low sensitivity was maintained to 120 volts when it rose exactly to its former value. The cycle could be repeated accurately and was caused by comparatively highly conductive paths forming between filament and anode. In the linear high-sensitivity region, the glow is dull and uniform.

9. Conclusion

It is hoped that the gauge may find application in fields of research and manufacture.

10. Acknowledgments

I wish to thank Mr. K. S. Brown, Valve Department Manager at Standard Telephones and Cables Pty. Limited for encouragement to complete and record this investigation. Notably, Mr. J. Howes has carried out much work on the project and many other members of the department have assisted with their particular skills.

11. References

1. M. Pirani, *Electronic Engineering*, v. 17, n. 204; February, 1945.
2. O. E. Buckley, *Proceedings of the National Academy of Sciences*, v. 2, p. 683; 1916.
3. Hausser, Ganschwindt and Rukop, *Telefunken 2*, v. 19, p. 14; 1920.
4. C. M. Fogel, *Proceedings of the I.R.E.*, v. 34, p. 302; May, 1946.
5. O. V. Baeyer, *Physikalische Zeitschrift*, v. 10, p. 168; March, 1909.
6. S. Dushman and C. G. Found, *Physical Review*, v. 17, p. 7; January, 1921; and v. 23, p. 724; June, 1924.
7. N. B. Reynolds, *Physics*, v. 1, p. 182; September, 1931.
8. E. K. Jaycox and H. W. Weinhart, *Review of Scientific Instruments*, v. 2, p. 401; July, 1931.
9. I. G. Maloff and D. W. Epstein, "Electron Optics in Television," McGraw-Hill Book Company, New York, New York, 1938; pp. 285-286.
10. C. G. and D. D. Montgomery, *Review of Scientific Instruments*, v. 9, p. 58; February, 1938.
11. R. B. Brode, *Review of Modern Physics*, v. 5, pp. 257-259; October, 1933.
12. P. T. Smith, *Physical Review*, v. 37, p. 808; 1931.
13. J. H. Fremlin, *Electrical Communication*, v. 21, n. 3, pp. 167-173; 1943.
14. W. G. Dow, "Fundamentals of Engineering Electronics," John Wiley and Sons, New York, New York, 1937; p. 45.
15. E. Rudberg, *Physical Review*, v. 50, pp. 138-150; July 15, 1936.
16. J. H. O. Harries, *Electronics*, p. 100; September, 1944.
17. T. J. Jones, *Physical Review*, v. 29, p. 822; 1927.
18. W. Bleakney, *Physical Review*, v. 35, p. 139; January, 1930.
19. K. T. Compton and C. C. van Voohris, *Physical Review*, v. 27, p. 724; 1926.
20. K. T. Compton and C. C. van Voohris, *Physical Review*, v. 26, p. 436; 1925.
21. P. T. Smith, *Physical Review*, v. 36, p. 1293; October, 1930.
22. A. L. Hughes and E. Klein, *Physical Review*, v. 23, p. 450; 1924.
23. W. Bleakney, *Physical Review*, v. 36, p. 1303; 1930.
24. J. T. Tate and P. T. Smith, *Physical Review*, v. 39, p. 270; 1932.
25. S. Dushman and A. H. Young, *Physical Review*, v. 68, p. 278; December, 1945.
26. F. E. Poindexter, *Physical Review*, v. 26, p. 859; December, 1925.
27. J. Blears, *Nature*, v. 154, p. 20; July, 1944.
28. W. B. Nottingham, *Physical Review*, v. 55, p. 203; January, 1939.

Long-Distance Telephone Communication Circuits*

By A. W. MONTGOMERY

Standard Telephones and Cables, Limited, London, England

WHILST THE voice-frequency-circuit mileage in use compares favorably with that of the newer carrier systems, attention in engineering and installation is being focused on multi-channel carrier telephony. A brief survey of the characteristics and fields of use of carrier telephony on open wire, cable, and coaxial conductors is presented. By standardising on a basic group of 12 channels and appropriate frequency bands for all types of carrier systems, a considerable amount of interworking flexibility is obtained and manufacturing costs are reduced through common use of filters and other components.

. . .

1. *Voice-Frequency Circuits*

Although the development of carrier circuits in recent years has rather stolen the limelight and has tended to relegate voice-frequency circuits into the background as far as the communications engineer is concerned, this is largely a technical eclipse, and it must not be forgotten that the amount of audio-frequency circuit mileage still compares with that provided by carrier means, and is therefore of significant importance to the traffic and financial side of an administration or operating company. As technical advances are made, the dominant long-distance-communication system of one day is replaced in importance by another. But the general growth of telecommunication requirements seems to ensure that in well-planned and well-equipped networks, the older systems always retain some uses, generally in a somewhat different role.

However, the technical and operating aspects of audio-frequency circuits are so well known that it is not proposed to deal with them in any detail except to say, in passing, that a case for audio-frequency cables still exists, particularly

on very short routes, and that the presence of the metallic conductors for each circuit may enable simple and inexpensive signalling facilities to be obtained.

2. *Carrier Circuits*

2.1 GENERAL

Land-line telephone transmission by carrier means has so far followed the technique of multiplexing on a frequency basis; that is to say, the audio-frequency band has been transposed to occupy a position in another part of the frequency range, and is then retransposed to the audio range at the receiving end. Other channels are obtained by transposing to adjacent parts of the frequency spectrum, permitting several channel frequencies to be transmitted over a common line and through common amplifiers, thus saving line plant.

Since attenuation increases with frequency, it is the aim of the engineer to use the frequency range available on the line to the best advantage, and this means limitation of the transmitted band to that considered adequate and desirable, and locating such bands as close to each other as possible without causing undue interference between channels. Limitation of the bandwidth and the segregation of channels is performed by filters.

It is obvious that the best system from both technical and economic standpoints must be a compromise between many factors. Thus, spacing channels further apart eases the filter requirements and therefore the costs, but it also means that fewer channels can be transmitted within a given frequency range. To increase the frequency range, a greater number of amplifiers are needed to give a closer spacing of repeaters. Similarly, compromises in amplifier output levels must be achieved, and a balance struck between high outputs with large valves and consequently expensive power supplies, or smaller outputs and valves, but closer repeater spacing.

* From a paper presented before the Associazione Elettrotecnica Italiana in Rome, Turin, and Milan during July, 1947.

These are just one or two of the factors that readily come to mind, but a great deal of thought has been given to such problems. To refer to only two instances of such studies, I might mention Jacobsen's paper,¹ which shows that the power-handling capacity of an amplifier carrying many speech channels can be determined from knowledge of the harmonic levels produced by the amplifier when loaded with a sine wave of known power. Also of interest is a paper by Hodgson and Roche² on the broad subject of the planning of systems, either individually or as links in long circuits, with special reference to the repeater spacing and output power and their influence on overall circuit noise.

Apart from these and other fundamental problems, there are details of circuit design with their bearing on manufacturing technique that must be solved effectively if the most economical equipment is to be obtained; for example, the number of components required and the space occupied can be reduced by combining several functions in one circuit. The incorporation of channel modulators designed to act as volume limiters is one illustration of this point. Another is the employment of the channel demodulator amplifier input coil to form part of the low-pass filter and equaliser, an economy possible in the 60-108-kilocycle crystal-filter system because the unwanted frequencies are well removed from the wanted band.

Of course, in considering technical products the cheapest in first cost is not necessarily the most economical in the long run, and perhaps nowhere is this more true than in the communication field, where ease of maintenance, stability, and provision for ordered growth are all of the greatest importance.

To obtain such ordered growth, it is obviously advantageous to build in units, and the basic unit, which the International Standard Electric Corporation uses (and which conforms to the recommendations of the Comité Consultatif International Téléphonique), is the group of 12 channels. The number 12 does not in itself have

¹ B. B. Jacobsen, "The Effect of Non-Linear Distortion in Multi-Channel Amplifiers," *Electrical Communication*, v. 19, pp. 29-53; July, 1940.

² K. G. Hodgson and A. H. Roche, "Design Factors Influencing the Economical Size and Spacing of Multi-Channel Telephone Repeaters," *Electrical Communication*, v. 19, pp. 100-107; October, 1940.

any predominant significance; indeed, 10 might find most favour if other factors were equal, but taken in conjunction with the frequency spacing of the channels and the types of filters used, this number is particularly suitable and contributes to ease of manufacture and therefore to economy.

2.2 12-CHANNEL CARRIER-ON-CABLE SYSTEM

A block schematic of the 12-channel carrier-on-cable system is shown in Fig. 1. Since this system is widely known, it will not be discussed in detail here.

Very briefly, however, the voice-frequency currents pass from the 2-wire line through the terminating equipment to the channel modulator, after which the lower sideband is selected by the band-pass filter. The carrier frequencies supplied to the 12 modulators range from 64 to 108 kilocycles in steps of 4 kilocycles, so that when the output currents from the 12 filters are united in the common transmitting path, they comprise a series of nominal 4-kilocycle bands lying between 60 and 108 kilocycles. The carrier currents themselves are substantially suppressed by the filters. This basic group-frequency band is then modulated at 120 kilocycles and the lower sideband, occupying the range of 12-60 kilocycles, is transmitted to the line through the transmitting amplifiers.

The receiving circuit reverses this process, the incoming group at 12-60 kilocycles being transposed to the 60-108-kilocycle range from which the individual channel band-pass filters select the appropriate bands for the associated channel demodulators, voice-frequency amplifiers, and terminations.

It will be noticed that all of the portion at the left of the diagram comprises the frequency-generating equipment; as this supplies many systems, its contribution to the sum total of apparatus in a quantity sense is unduly accentuated by such a diagram. This is, of course, the heart of the system, and so must be made to be completely reliable, even if this involves what may at first seem to be quite a heavy cost. However, when this cost is divided among the individual channels, it does not represent a high proportion of the cost per channel.

When apportioning the amount and cost of the different classes of apparatus, it should be noted

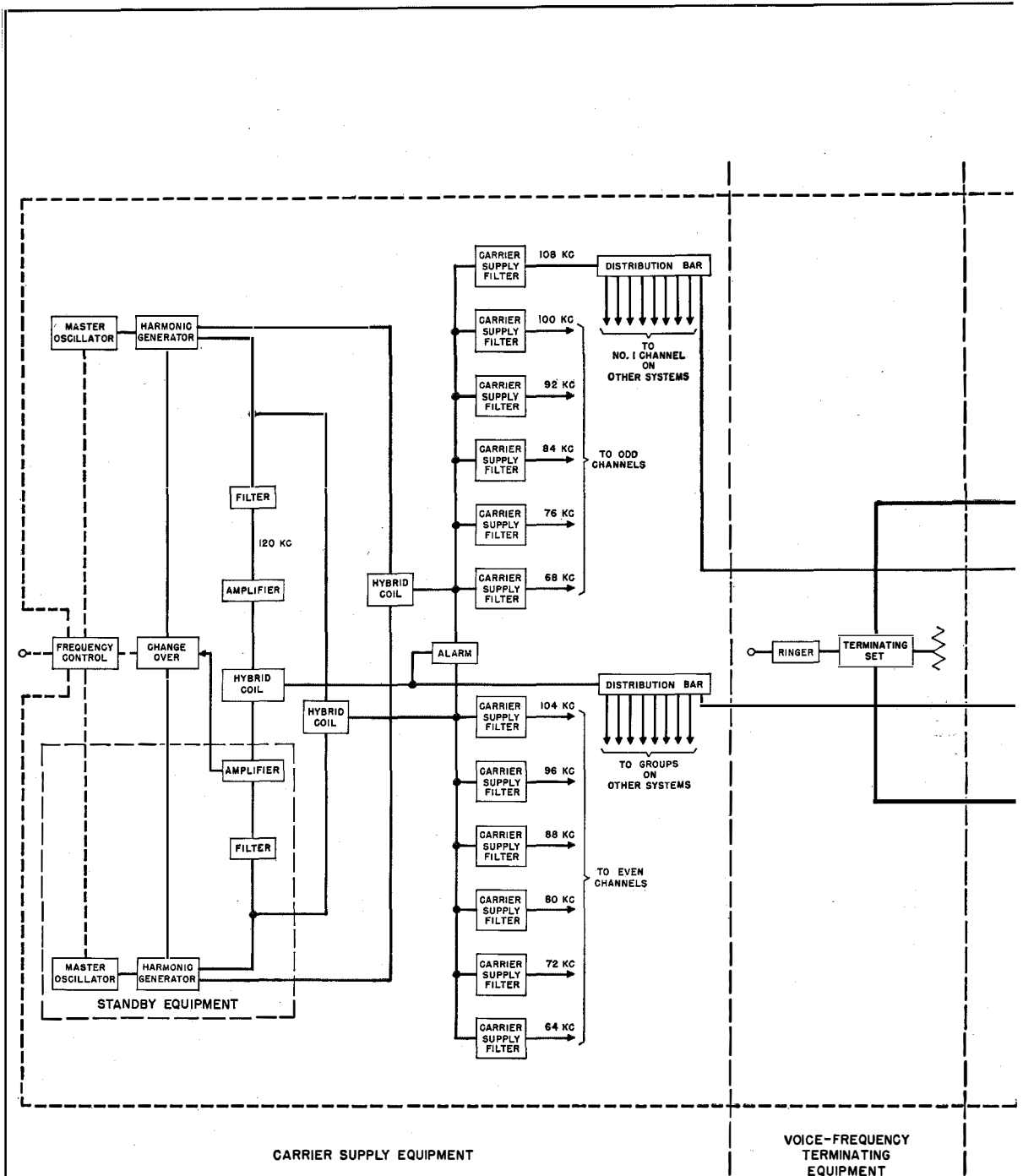
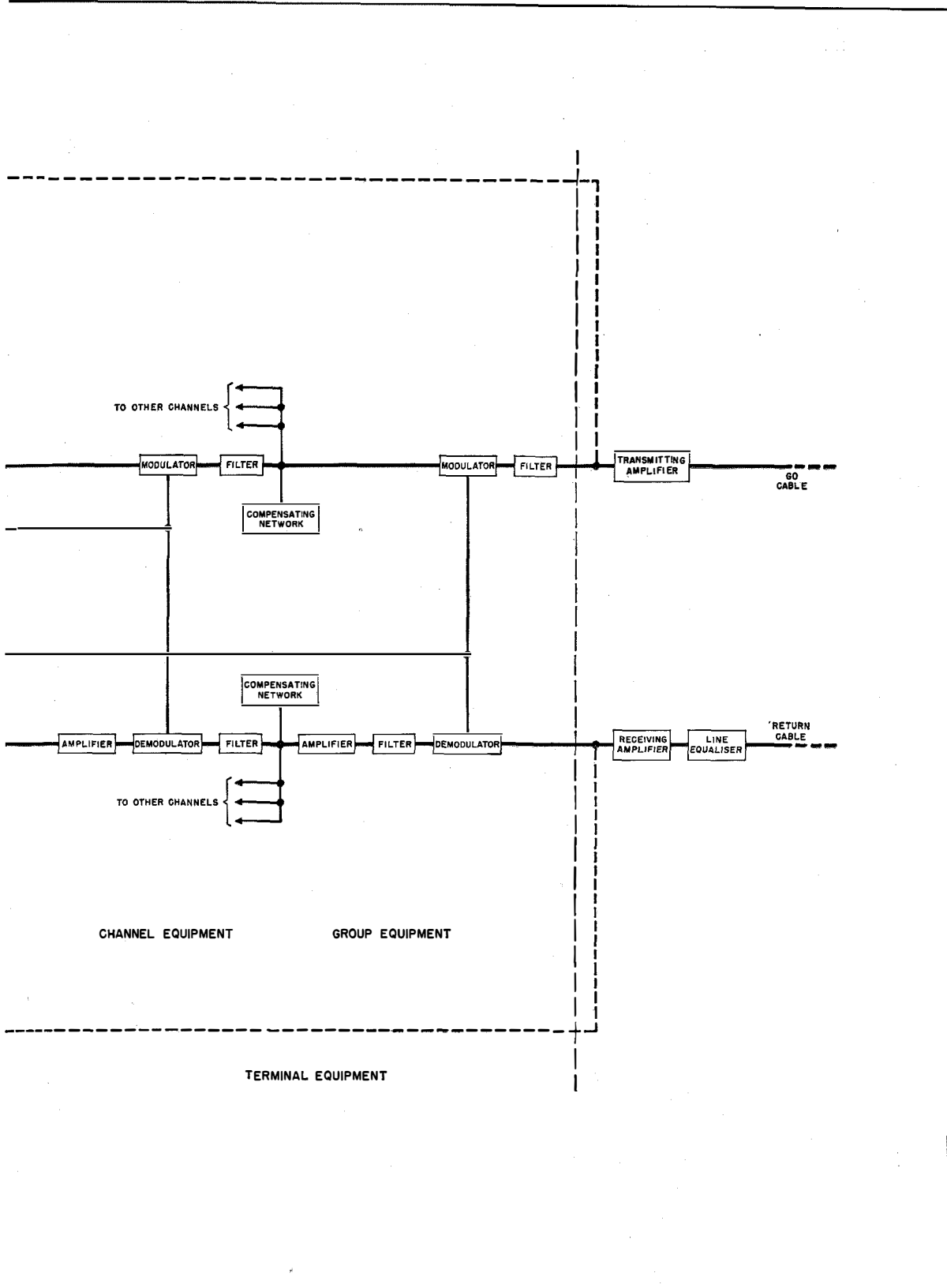

Fig. 1—Block diagram of 12-channel carrier-on-cable terminal equipment.



that a signalling unit and terminating equipment are required for each channel. Moreover, the terminal equipment proper comprises a modulator and band-pass filter per channel in the sending path, and similar equipment, together with a small single-valve amplifier, in the receiving path for each channel.

Equipment common to all 12 channels is made up of the filter-compensating networks, the group modulator, demodulator, filters, receiving amplifier, line-transmitting amplifier, and receiving equaliser and amplifier.

It is important to realise that whereas the carrier equipment as shown can supply 120 individual channel terminals (or 480 channel terminals with the addition of 12 carrier amplifiers), and that the group and line equipment serves 12 channel terminals, each individual channel terminal requires 2 band-pass filters and one signalling unit as well as certain smaller items. The cost of the overall terminal equipment lies primarily, therefore, in the channel filters and the signalling unit.

It would be possible to achieve a similar technical result without crystal filters by using other modulation processes, but experience shows, after repeated checks at intervals, that the crystal-filter method proves more economical in production and use.

The 12-channel cable system is designed to work on a 4-wire basis using one cable for transmission in one direction and another for transmission in the opposite direction. This results in a very simple repeater comprising an equaliser and amplifier in each direction.

Repeater spacing is normally based on a loss of 6 nepers (52 decibels) at 60 kilocycles, which means that repeaters will be about 32 kilometers (19.9 miles) apart, although some variation may be allowed.

2.3 24-CHANNEL CARRIER-ON-CABLE SYSTEM

With closer repeater spacing, more accurate cable balancing, and suitable line equalisers, another group of 12 channels can be operated on the same cable pairs, thus doubling the circuit capacity. This can be achieved in a simple manner by adding a basic group at 60–108 kilocycles to the nominal 12-channel group at 12–60 kilocycles. Fig. 2 shows the 24-channel system built

up from the 12-channel system. High-pass and low-pass crystal-filter combinations are used to separate and combine the two groups, and additional amplifiers are employed to compensate for the loss in these filters and to produce the required levels at the flexibility points. These flexibility points are used for switching channel groups and high-frequency lines as required, and are termed "Group-Distribution Frame" and "High-Frequency-Repeater Distribution Frame." At the group-distribution frame, channels are at the basic group frequency of 60–108 kilocycles. The sending level at this point is -0.92 neper (-8 decibels), and the receiving level is -4.25 nepers (-37 decibels) with reference to the transmitting toll-test-board level.

At the high-frequency-repeater distribution frame, the frequencies lie between 12 and 108 kilocycles with a normal level of $+0.575$ neper (5 decibels) for both sending and receiving.

The line equalisers and amplifiers are designed to cover the range 12–108 kilocycles, and, in fact, the 24-channel amplifier is now standard equipment whether the circuits are to be used for 12- or 24-channel operation. The repeater spacing for 24-channel systems is about 23–25 kilometers (14.3–15.5 miles) for 1-millimeter (18 American Wire Gauge) conductors, or 29–32 kilometers (18.0–19.9 miles) for 1.3-millimeter (16 American Wire Gauge) pairs. Where circuit groups and distances do not justify the use of coaxial systems, and operation of carrier on multi-pair cables is economical, the 24-channel system, in the author's opinion, represents the most efficient and economical method of using the cables. This view is confirmed by considered opinion in the British Post Office, as expressed by Mr. Chamney in his recent paper.

2.4 36- AND 48-CHANNEL CARRIER-ON-CABLE SYSTEMS

A great deal of study has been given to systems employing more than 24 channels, and 36- and 48-channel systems and suitable repeaters can be supplied, but there are two main points that require careful consideration.

In the first place, they are generally uneconomical when compared with 24-channel systems, and certainly when compared with systems using coaxial lines.

Secondly, experience shows that extension beyond 24 channels introduces difficult far-end-crosstalk problems such that the higher-frequency channels may be restricted to comparatively short distances and rendered unsuitable for long national or international circuits. In certain special cases, such systems may possibly be justified, and the International Standard Electric Corporation has designed and produced 48-channel equipment for the Dutch Administration. The distances involved in Holland are abnormally small, however, and existing repeater stations are available at extremely short intervals.

2.5 COAXIAL SYSTEM

It should be noted that all the systems so far mentioned are built up from the basic group of 12 channels, transposed or not, as the requirements of the system demand.

This principle is followed in the coaxial system, in which the *basic group* of 12 channels is used as a unit to build a *basic supergroup* consisting of five such groups, i.e., 60 channels. Ten basic supergroups are then transposed to adjacent positions in the frequency spectrum and transmitted over a coaxial tube consisting of a central conductor positioned by insulating washers inside an outer copper cylinder, which serves as the other conductor. One such tube is used for transmission in one direction and another tube in the same cable is used for transmission in the reverse direction.

Fig. 3 shows the frequency transpositions involved. Five basic groups in the range of 60–108 kilocycles are modulated by carriers of 420, 468, 516, 564 and 612 kilocycles, and the lower sidebands are then selected by filters to produce the basic supergroup of 60 channels in the range 312–552 kilocycles. Nine such basic supergroups are modulated by carrier frequencies of 612, 1116, 1364, up to 2604 and 2852 kilocycles. The lower sidebands of these, together with an untransposed basic supergroup, produce a series of 600 channel bands for transmission on the line in the range 60–2540 kilocycles. The untransposed basic supergroup forms supergroup 2 on the line.

2.5.1 Coaxial Terminal Equipment

The arrangement of apparatus at terminals, excluding the carrier-supply equipment and ter-

minal repeaters, is shown in Fig. 4. Normal channel bay equipment, similar to that required for systems described above, is used. The group-frequency-transposing equipment modulates five groups to produce a basic supergroup, and it will be noticed that the groups are combined by means of a hybrid coil with alternate group-frequency band-pass filters connected in parallel. This eases the filter requirements, since impedance irregularities at the edges of the filters due to proximity are avoided, and the effective discrimination is improved. The individual basic supergroups are amplified, modulated, and selected by filters, and are then combined by means of a hybrid coil before passing through a common amplifier to the transmitting line-repeater equipment. A total of 480 channels (8 supergroups) are handled in this way, while two more supergroups may be added in the manner shown.

The receiving portion of the terminal circuit is similar, except that the process is reversed. The extreme economy in amplifiers and valve circuits on this system—combined with adequate provision for reliability—should be noted. In the whole of the sending path there is one single-stage amplifier per supergroup, apart from the auxiliary transmitting amplifiers of which there are but 1 for 8 supergroups or 2 for 10 supergroups. In the receiving path, there is a single-stage supergroup amplifier, a 2-stage group amplifier, and a single-stage channel amplifier. Because the supergroup amplifiers are shared by 60 channels, the valves are duplicated, so that failure of one valve will not cause a large number of circuits to fail. The auxiliary transmitting amplifiers are similar, i.e., single-stage but containing two valves.

Summarising, 600 individual channel terminals require 600 single-stage channel amplifiers, 50 2-stage group amplifiers, 20 single-stage supergroup amplifiers (with duplicate valves), and 2 single-stage auxiliary transmitting amplifiers (with duplicate valves).

When the carrier-supply and terminal-repeater equipment is also added, the number of valves per individual channel terminal at a fully equipped 10-supergroup terminal, excluding signalling equipment, is less than 1.4. This is a considerable achievement, and is reflected in ease of maintenance, low power requirements, and reduced annual charges.

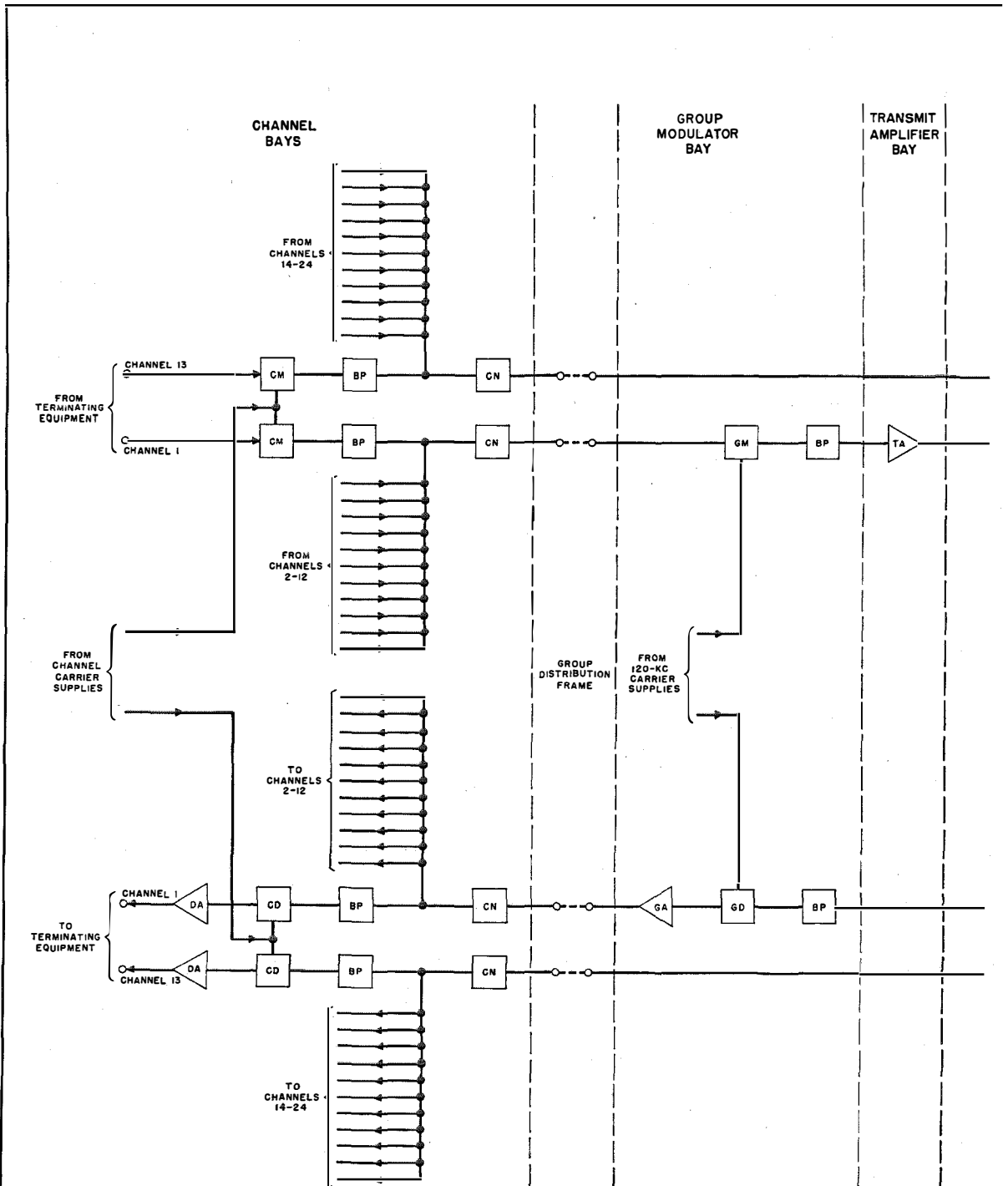
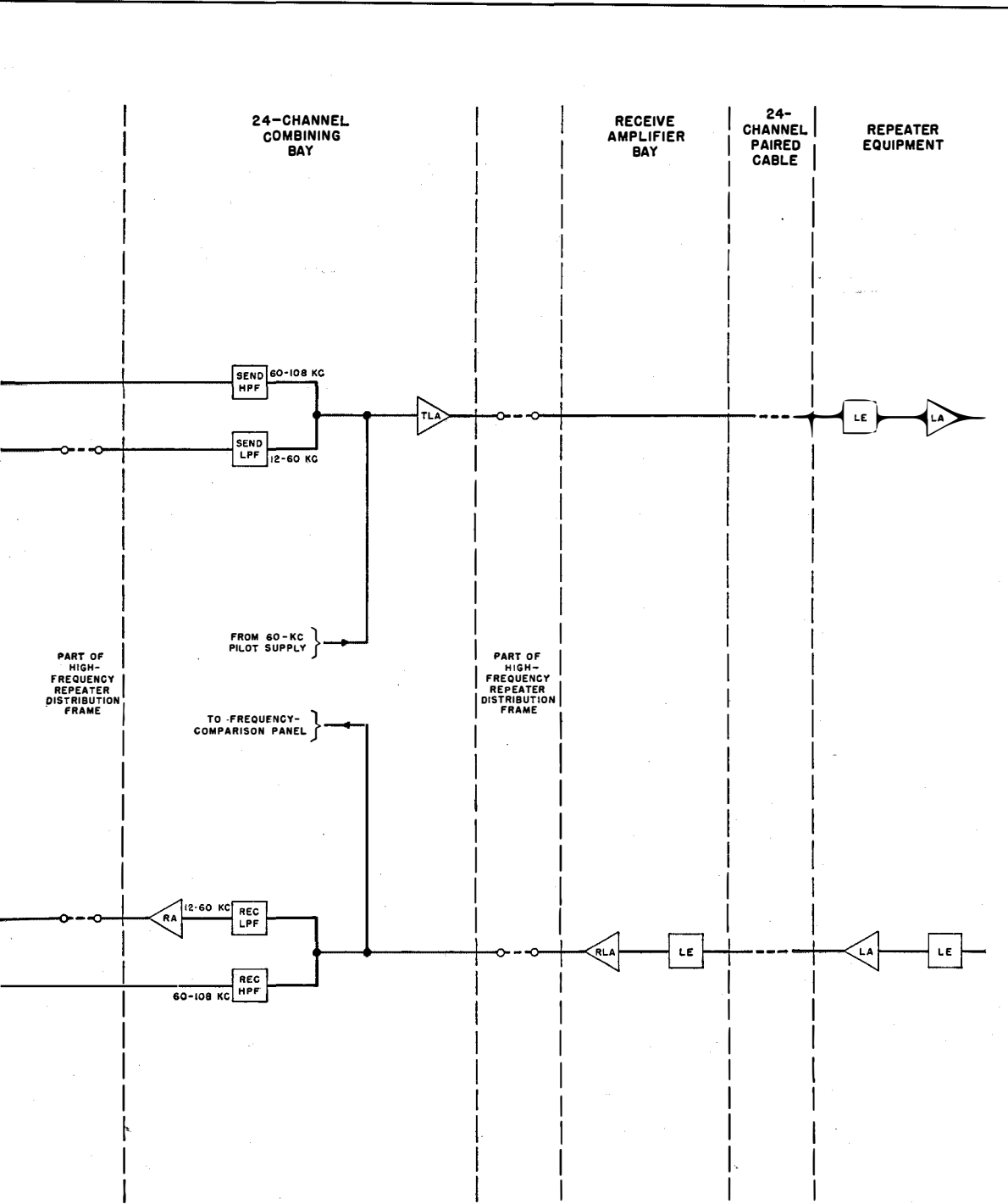
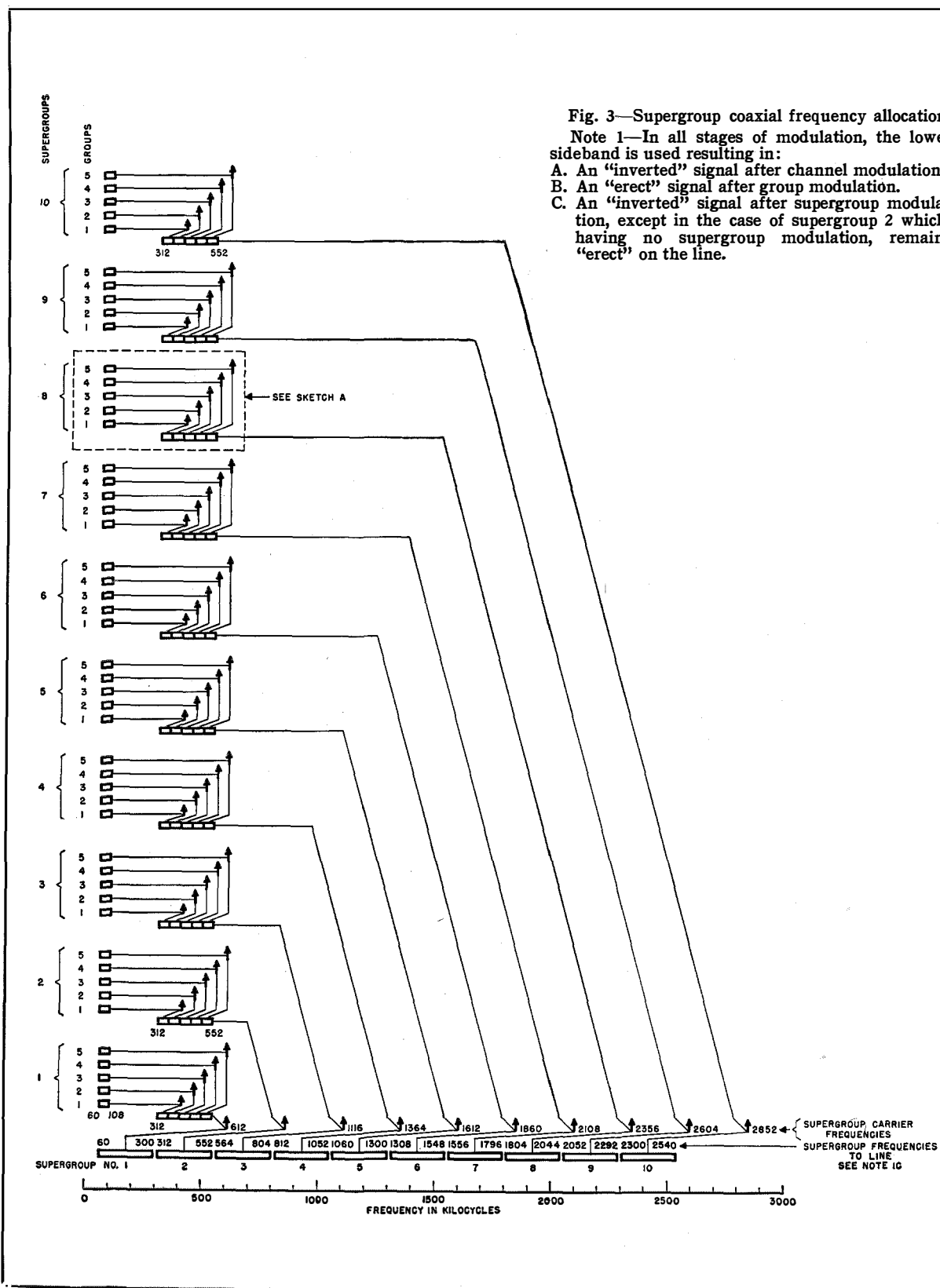
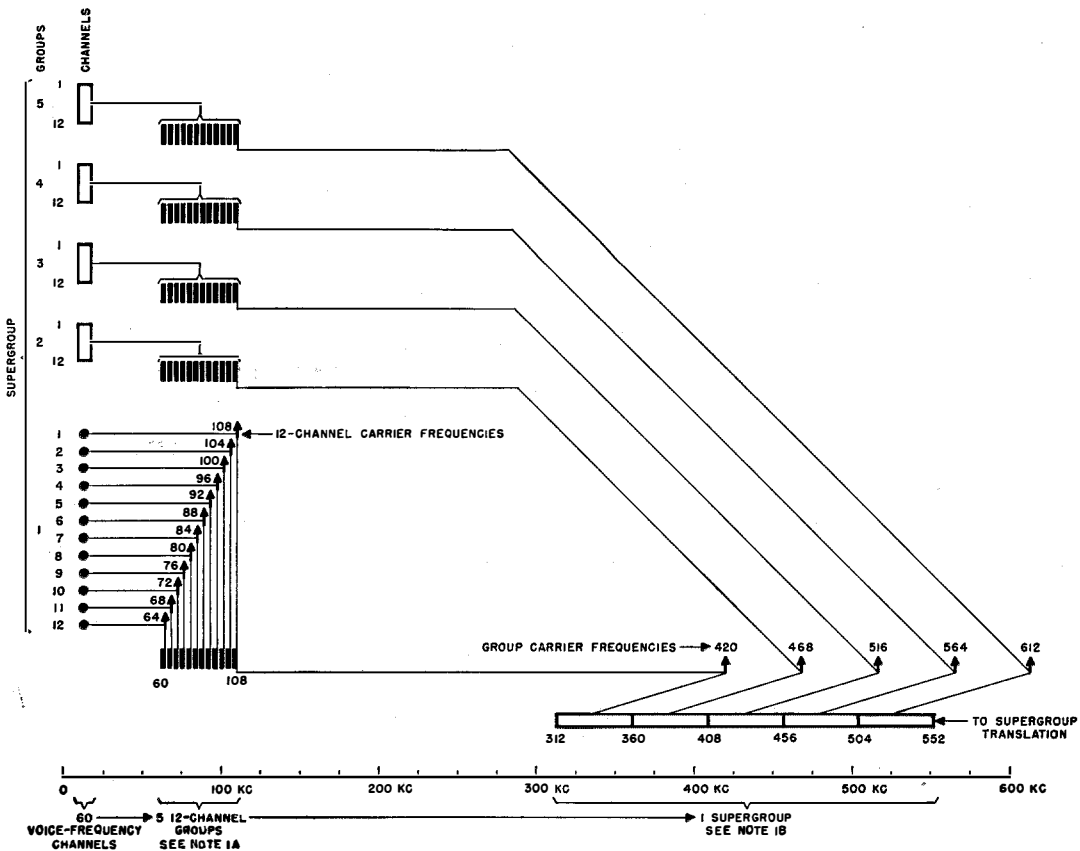

Fig. 2—Block diagram of transmission circuits for terminal and repeater. The letters in the boxes indicate the following: BP, Band-pass filter. CD, Channel demodulator. CM, Channel modulator. CN, Compensating network. DA, Demodulator amplifier. GA, Group amplifier. GD, Group demodulator. GM, group modu-



lator. HPF, High-pass filter. LA, Line amplifier. LE, Line equalizer. LPF, Low-pass filter. RA, Receive amplifier. RF, Receive filter. RLA, Receive line amplifier. TA, Transmit amplifier. TLA, Transmit line amplifier.





SKETCH A
TYPICAL SUPERGROUP PRIOR
TO SUPERGROUP TRANSLATION

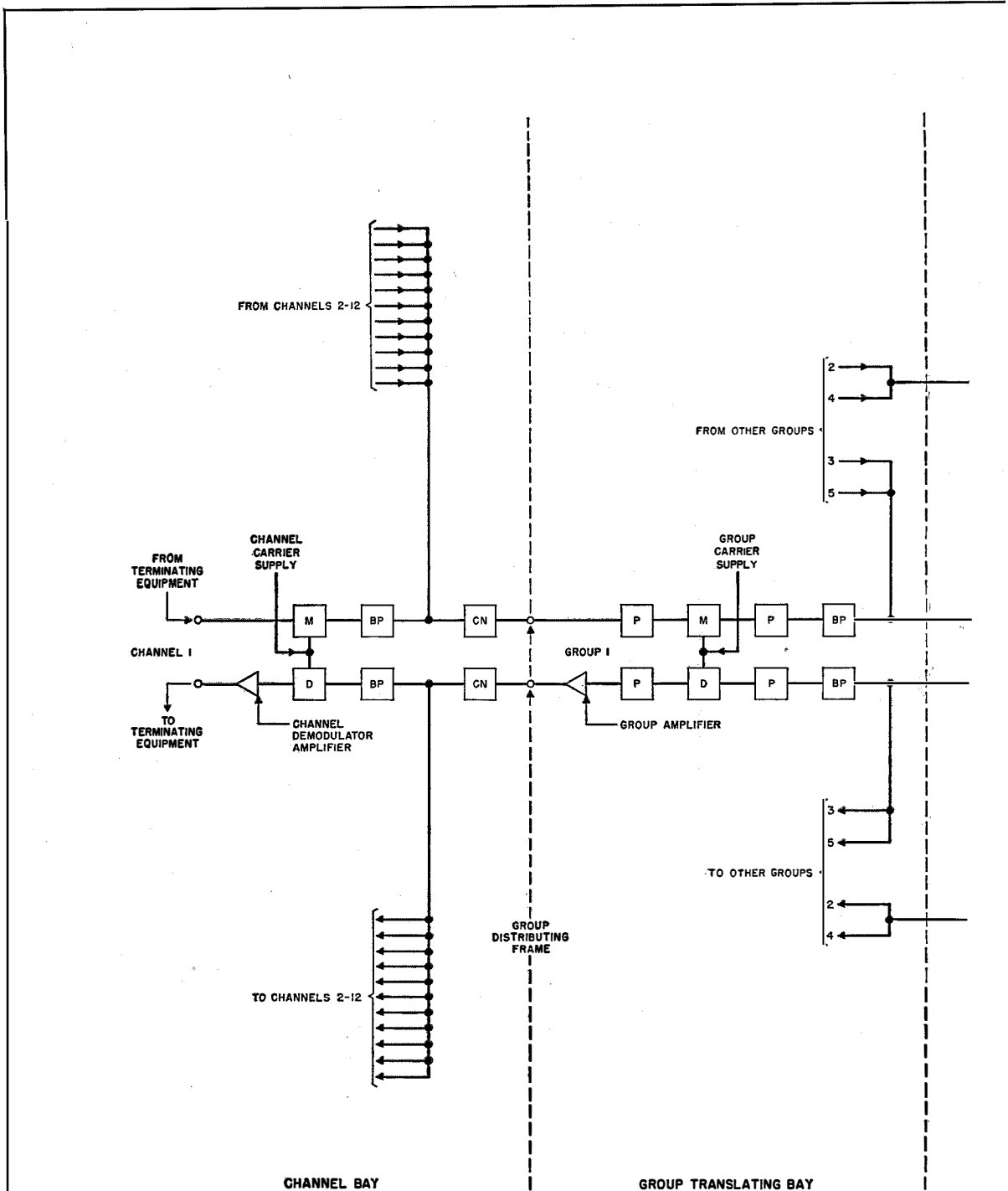
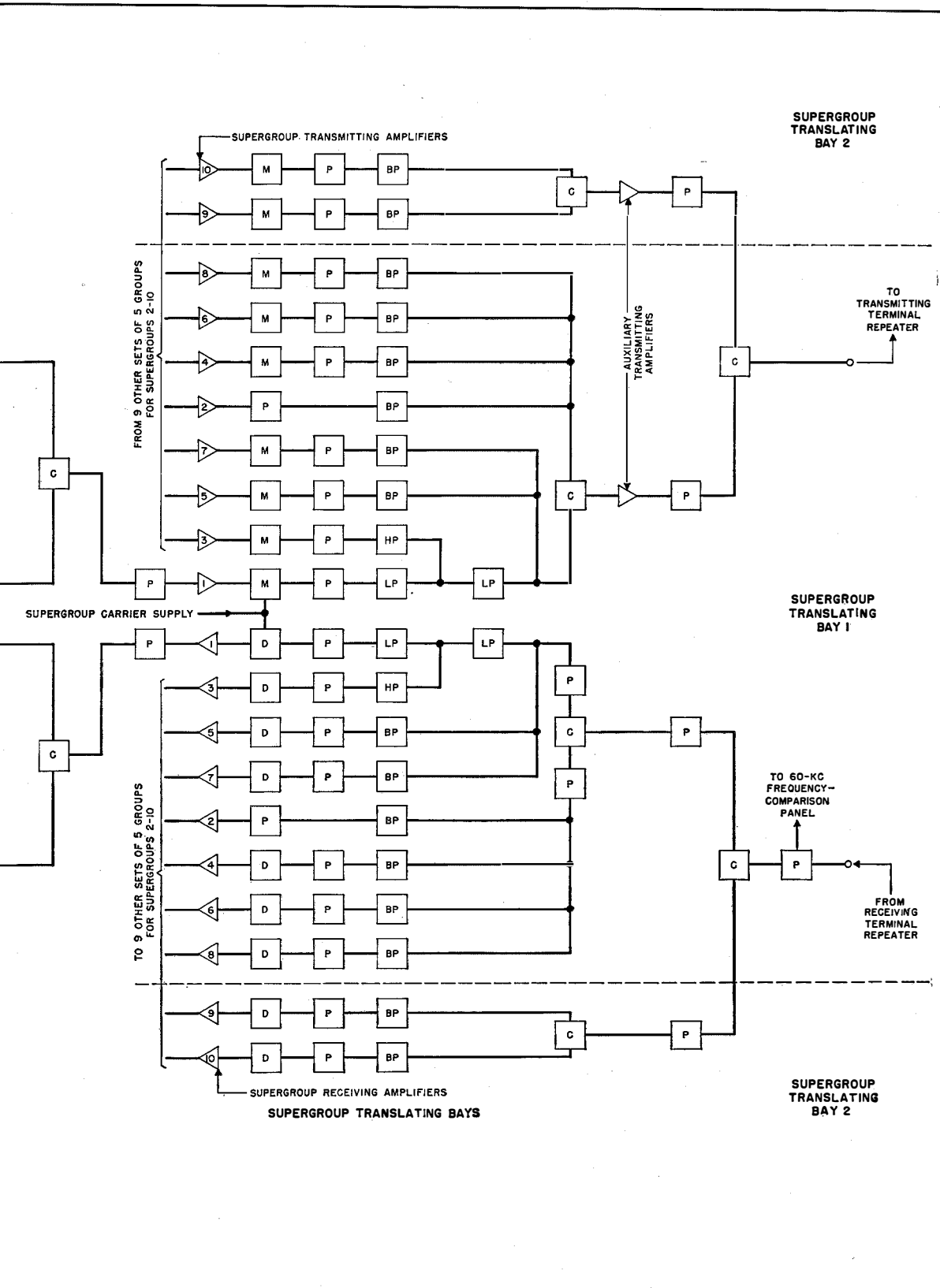

Fig. 4—Block diagram of terminal equipment, excluding terminal repeaters. The letters in the boxes indicate the following: C, Combining panel. BP, Band-pass filter. CN, Compensating network. D, Demodulator. HP, High-pass filter. LP, Low-pass filter. M, Modulator. P, Resistance pad.



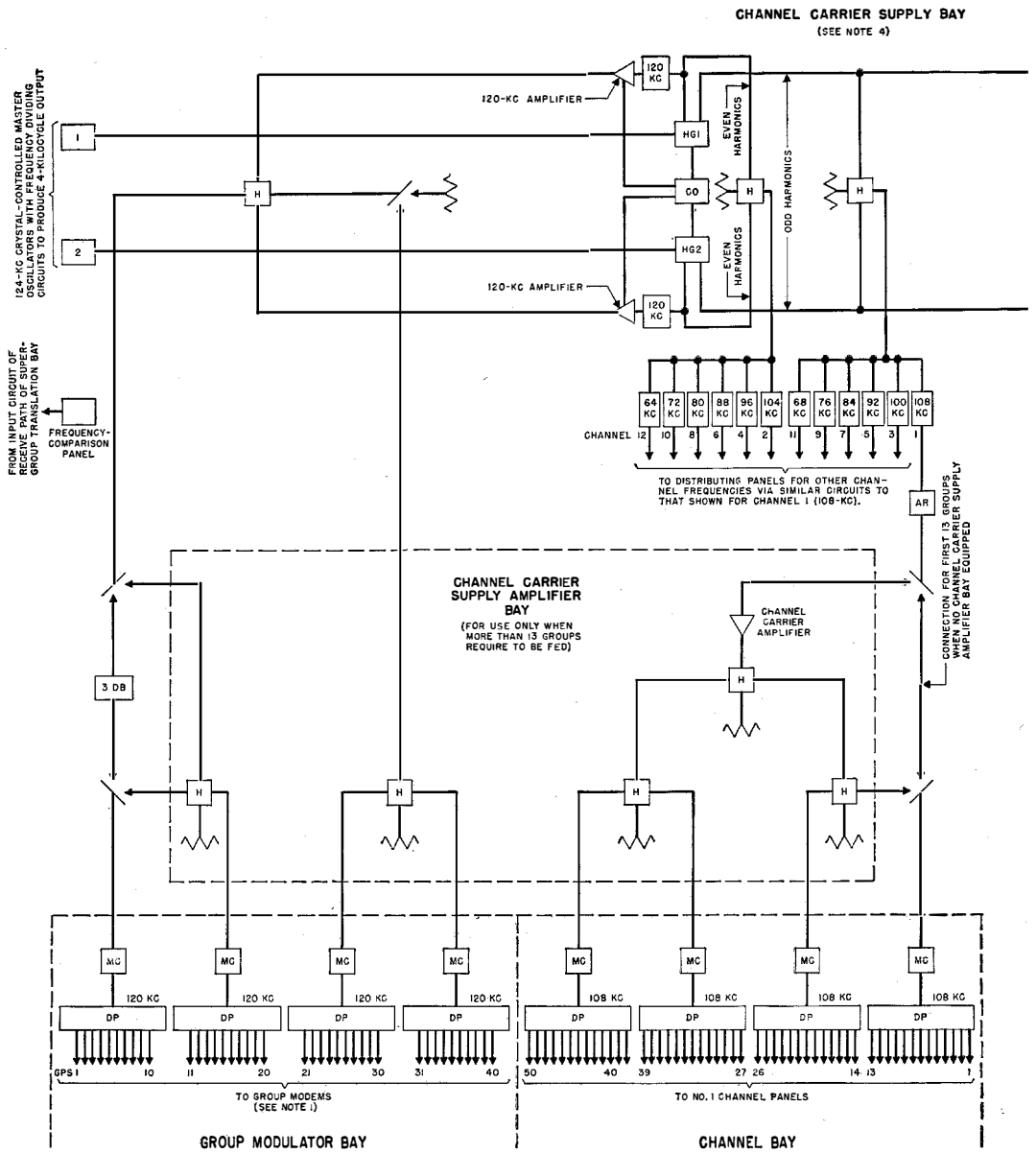
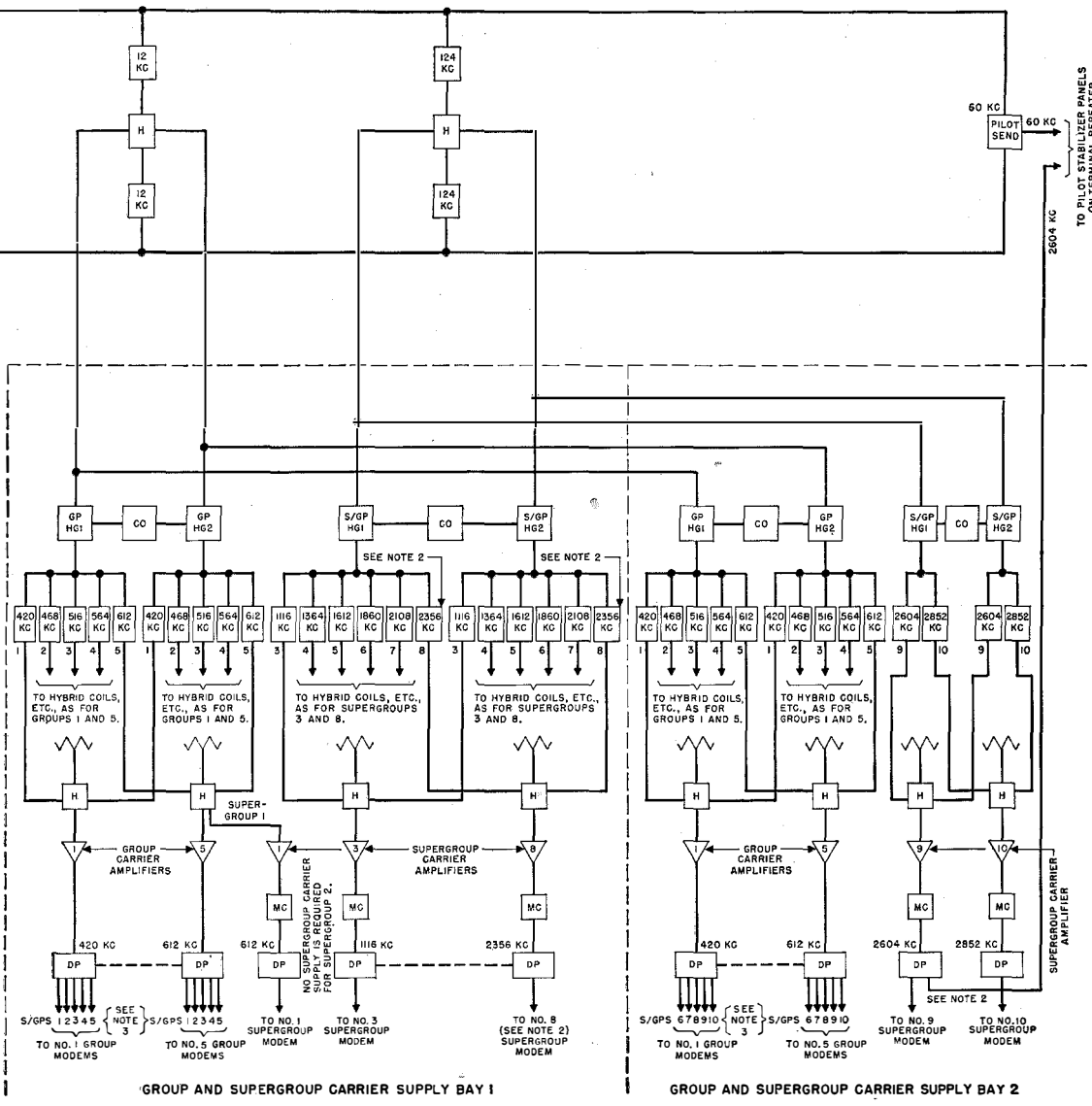

Fig. 5—Block diagram of carrier supply. The letters in the boxes indicate the following: AR, Adjusting resistance. CO, Change-over (switching) panel. DB, Resistance pad of indicated attenuation in decibels. DP, Distributing panel. GP, Group. H, Hybrid coil. HG, Harmonic generator. KC, Band-pass filter of indicated midband frequency in kilocycles per second. MC, Matching coil. S/GP, Supergroup.

Note 1—A 120-kilocycle supply is only required for use with a group-modulator bay when the latter is used for extending a coaxial group direct to the first 12 channels of a 24-channel multi-conductor carrier system.

Note 2—When only 7 or fewer supergroups are required, the second group and supergroup carrier supply



bay can be omitted. In this case, the 2356-kilocycle filter normally used for supergroup 8 is replaced by a 2604-kilocycle filter and the 2604-kilocycle pilot feed is taken from the amplifier normally associated with supergroup 8 instead of from that normally associated with supergroup 9.

Note 3—When 10 supergroups are initially equipped, each group-carrier amplifier on bay 1 would feed supergroups 1-5 and those on bay 2 would feed supergroups 6-10. The amplifiers, however, have a capacity for feeding a maximum of 8 supergroups, so that when bay 2 is not equipped, their load can be increased accordingly.

Note 4—The equipment not shown within the dashed line is mounted on the channel carrier supply bay.

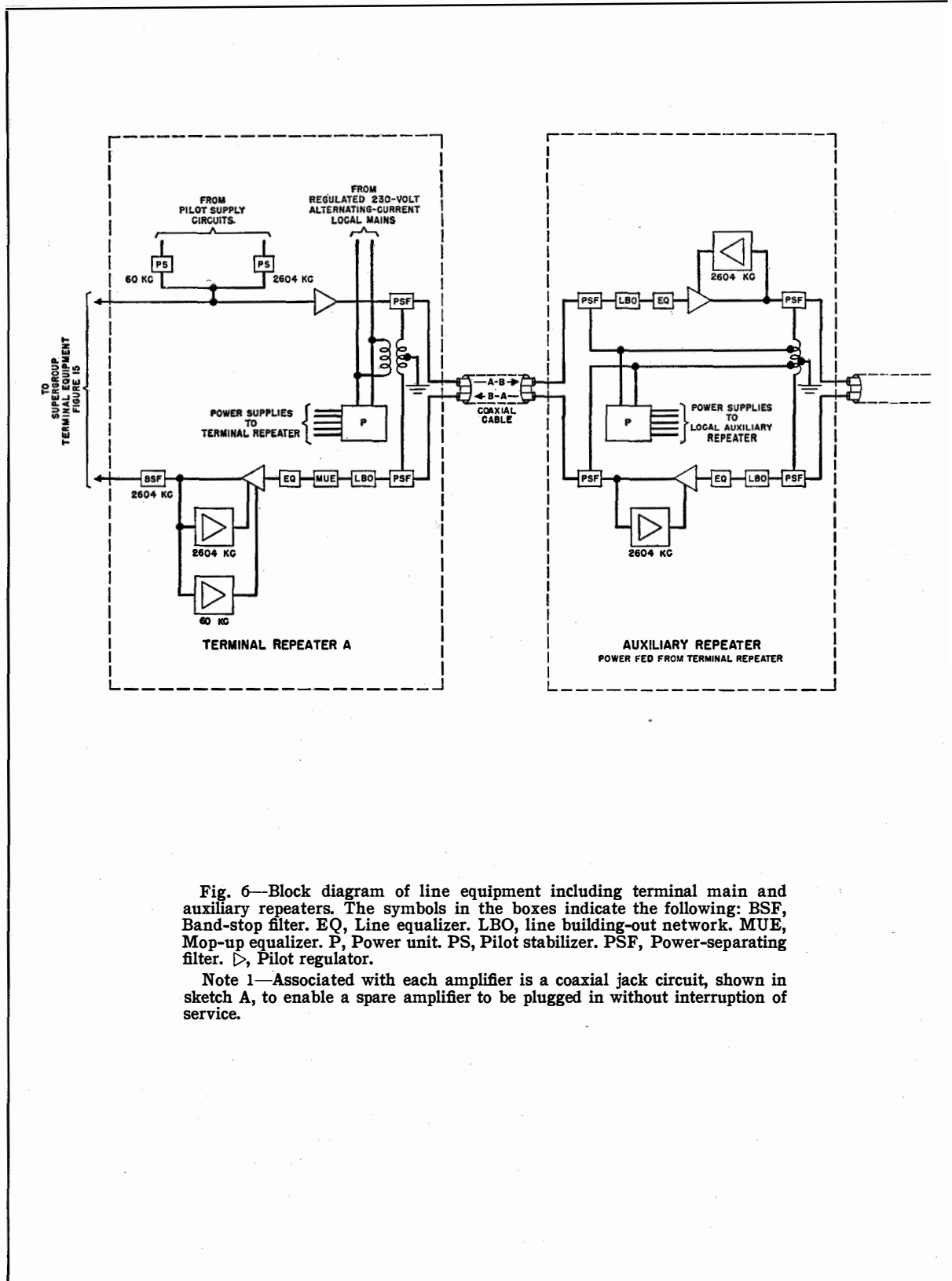
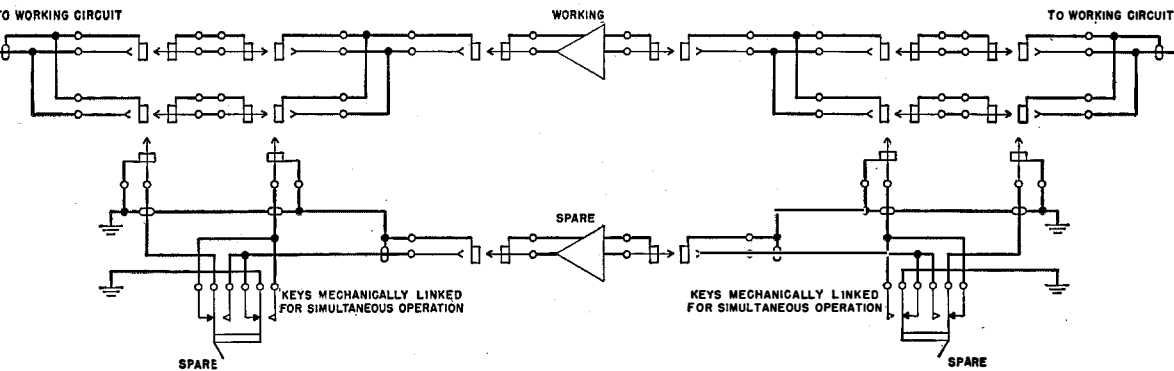
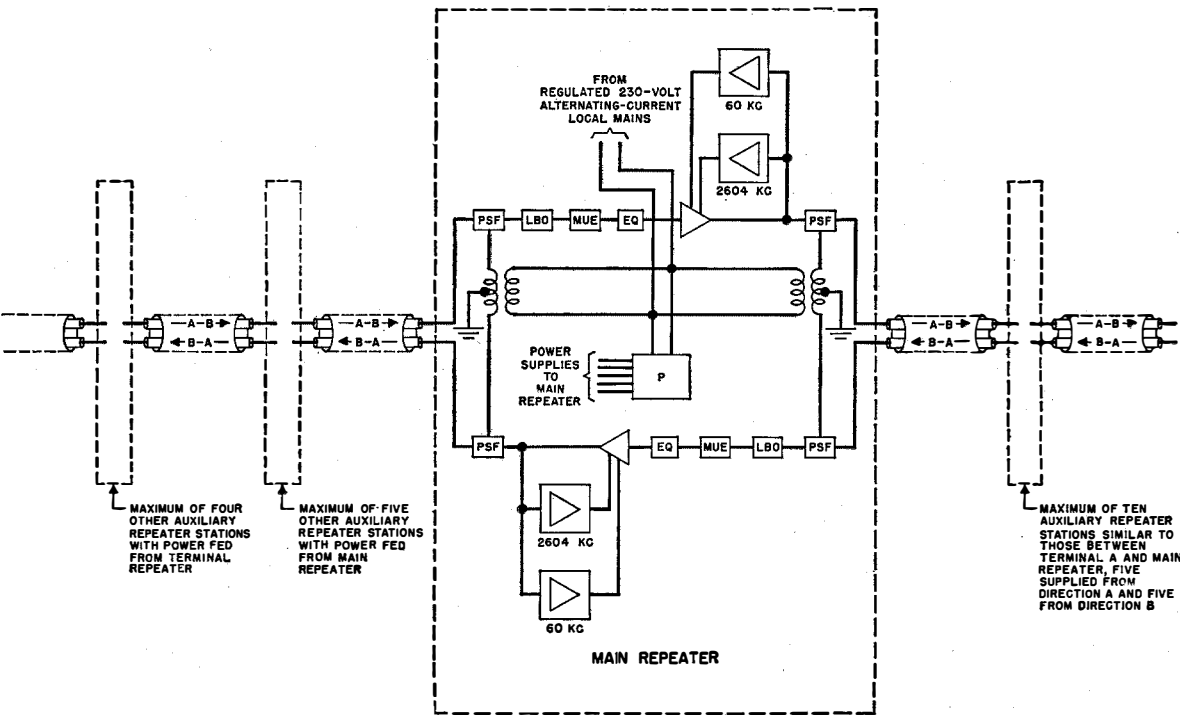

Fig. 6—Block diagram of line equipment including terminal main and auxiliary repeaters. The symbols in the boxes indicate the following: BSF, Band-stop filter. EQ, Line equalizer. LBO, line building-out network. MUE, Mop-up equalizer. P, Power unit. PS, Pilot stabilizer. PSF, Power-separating filter. \triangleright , Pilot regulator.

Note 1—Associated with each amplifier is a coaxial jack circuit, shown in sketch A, to enable a spare amplifier to be plugged in without interruption of service.



SKETCH A
(SEE NOTE 1)

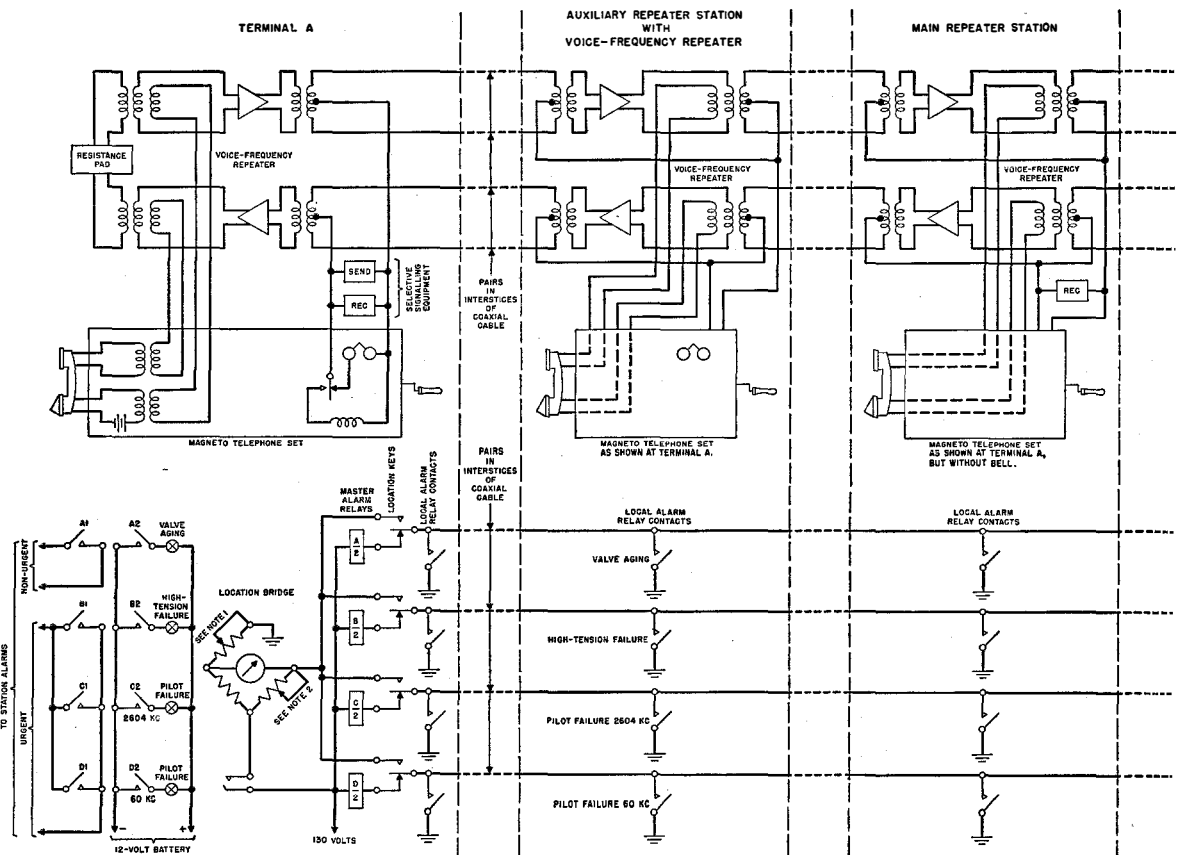
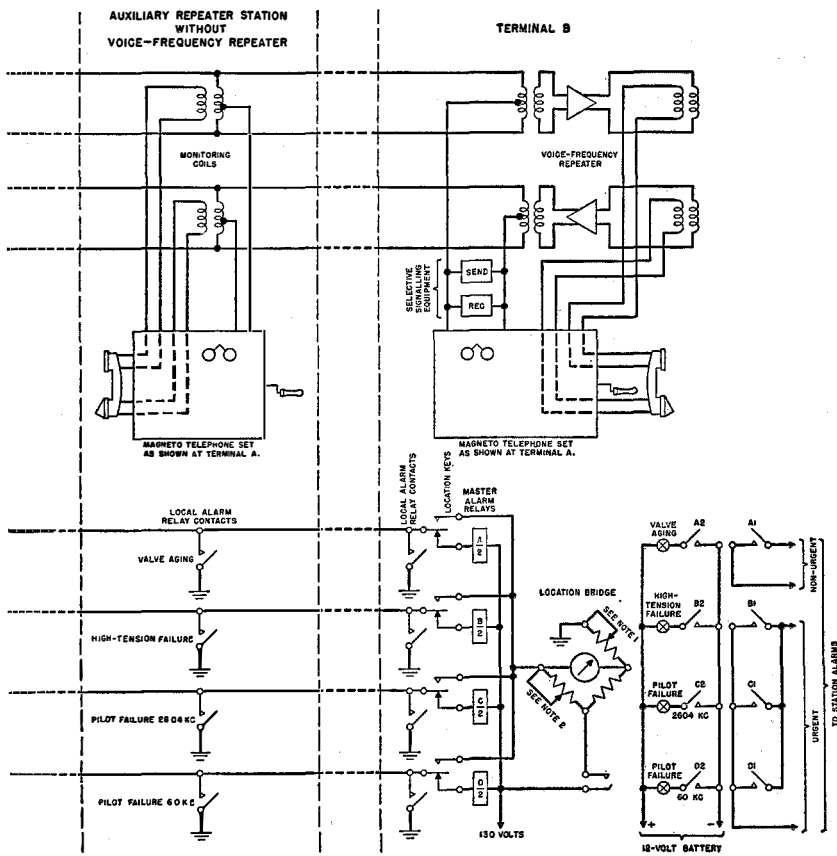

Fig. 7—Block diagram of speaker and alarm system.
Note 1—The variable arm of the location bridge can be calibrated in actual repeater-station code names.
Note 2—The ratio-arm adjuster is provided to compensate for change in line resistance with temperature.



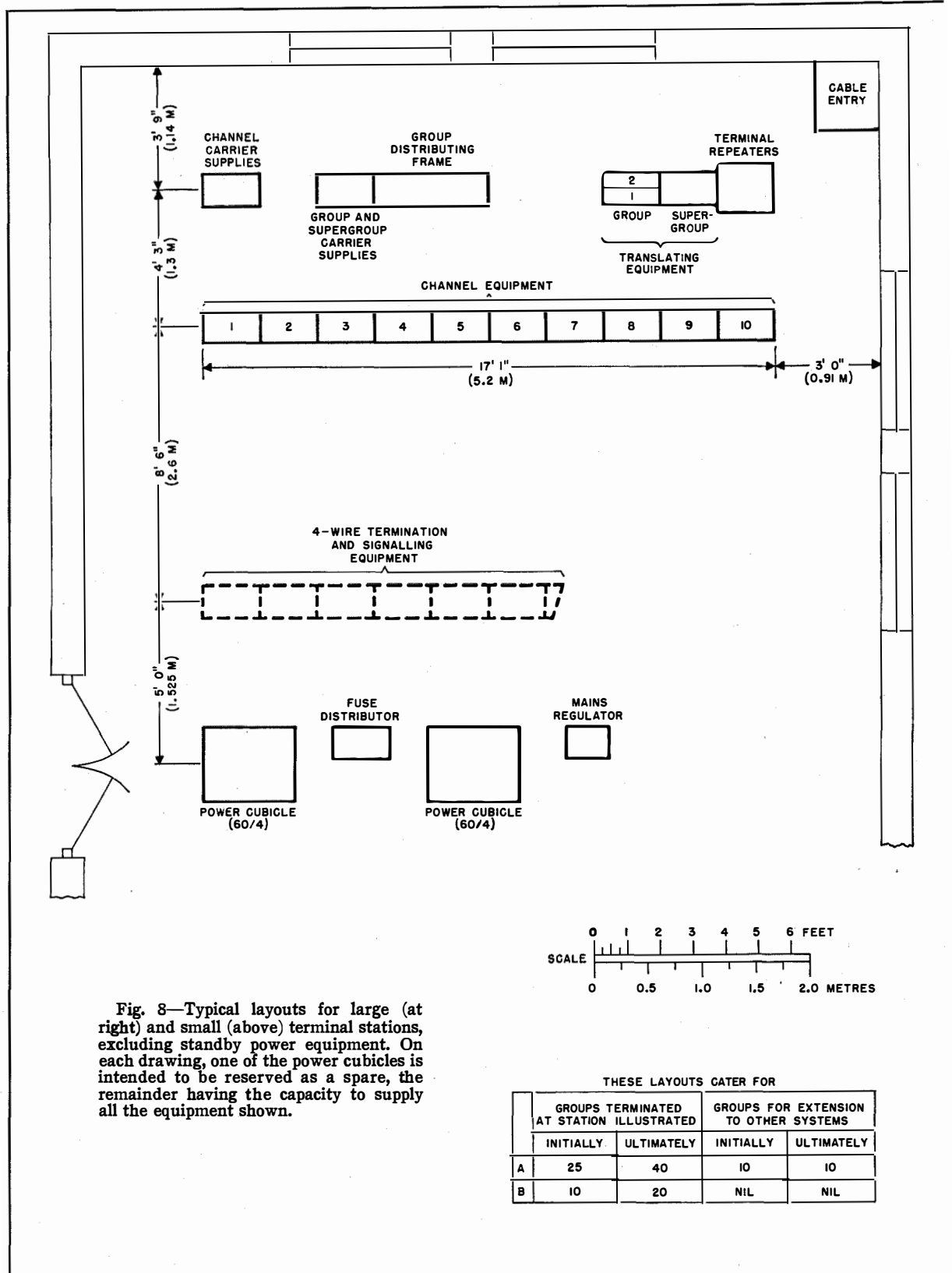
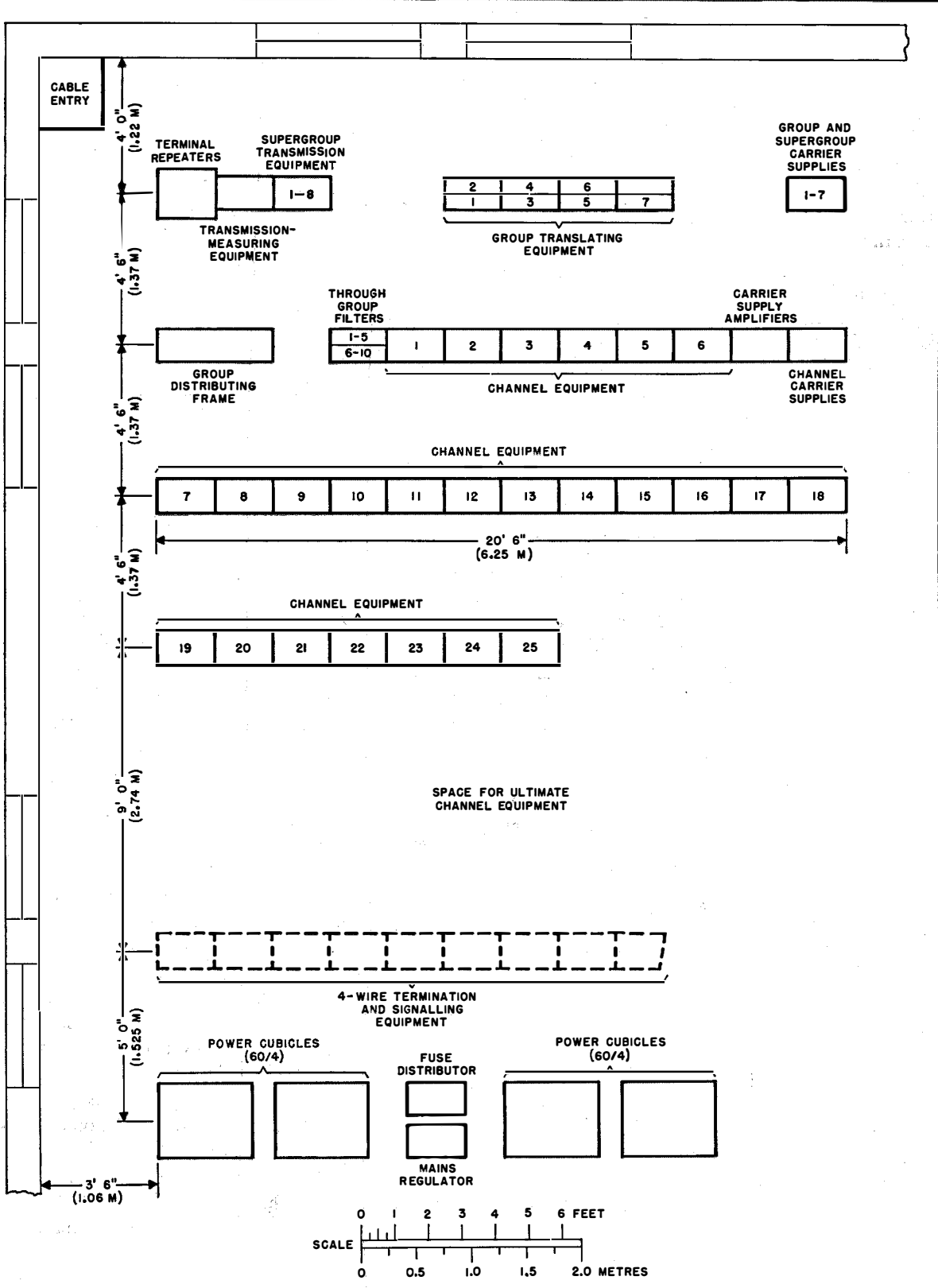

Fig. 8—Typical layouts for large (at right) and small (above) terminal stations, excluding standby power equipment. On each drawing, one of the power cubicles is intended to be reserved as a spare, the remainder having the capacity to supply all the equipment shown.

THESE LAYOUTS CATER FOR

	GROUPS TERMINATED AT STATION ILLUSTRATED		GROUPS FOR EXTENSION TO OTHER SYSTEMS	
	INITIALLY	ULTIMATELY	INITIALLY	ULTIMATELY
A	25	40	10	10
B	10	20	NIL	NIL



The carrier-supply circuit is shown in Fig. 5. The channel carrier-supply equipment for frequencies of 60 kilocycles for the pilot and 64–108 kilocycles for channel modulators is similar to that used on 12- and 24-channel systems. In addition, provision can be made to obtain 120 kilocycles for group-modulation purposes when required for transposing groups of a coaxial system directly to the 12–60-kilocycle range of a 12- or 24-channel system.

Since reliability of the whole terminal depends on the carrier supplies, vulnerable portions are duplicated, either completely, or by using additional valves; provision is made for automatic changeover from one set to the other in case of failure.

Each carrier-generating set consists of a crystal-controlled master oscillator with a fundamental frequency of 124 kilocycles. This is temperature compensated to give stability within ± 1 part in 10 million, so that synchronisation is not necessary, although provision is made for occasional frequency comparison between terminals. The 124-kilocycle output is subdivided to produce 4 kilocycles to drive the harmonic generator supplying the harmonics of 4 kilocycles to the channel carrier-frequency-selecting filters and distributing points. The odd harmonics are provided by a saturated inductance, and the even harmonics by a rectifier circuit.

Odd harmonics of 12 kilocycles are produced in another frequency-generating panel to supply the 420-, 468-, 516-, 564-, and 612-kilocycle supplies for the group modulators and demodulators, the 612-kilocycle frequency also being used for number 1 supergroup. Odd harmonics of 124 kilocycles produced by a third generator provide the carrier frequencies for the remaining supergroup transposition processes. One of these frequencies—2604 kilocycles—is also used as a pilot to control the line amplifiers. Further details of the carrier-supply arrangements are given in the diagram.

2.5.2 Coaxial-Line Equipment

The line equipment is considered to include the line amplifying and equalising equipment, pilot-control apparatus, and power-separating filters at both terminals and repeaters, as well as the coaxial tubes themselves.

Fig. 6 is a schematic diagram showing various types of stations.

At the sending terminal, two pilot frequencies at 60 kilocycles and 2604 kilocycles are added to the outgoing supergroup signals and pass through the line amplifier combined with the power-separating filter to the coaxial tube. The level of each channel at this point is -1.15 neper (-10 decibels) relative to the transmitting toll-test-board level. At intermediate repeaters and at the distant receiving terminal, the incoming signals pass through the power-separating filter, building-out network, and equaliser, to the line amplifier; the gain and equalisation here are automatically controlled by the pilot currents through the use of thermistors. Thermistors are circuit elements in which the electrical resistance varies widely with change in temperature, and hence, with the amount of current passing through the thermistor.

Changes in line attenuation are mainly attributable to changes in temperature of the cable, and the “form” of the change is therefore predictable. This makes it possible to effect the necessary compensation by means of the 2604-kilocycle pilot only, at the majority of stations; while correcting for deviations at the low end of the frequency range by means of the 60-kilocycle pilot at certain repeaters and at terminals.

2.5.3 Coaxial-System Power Supplies

The channel, group, supergroup, and carrier-generating equipment at the terminals operate from 21- and 130-volt direct-current supplies. Single-phase alternating-current power at 50 cycles per second supplies the coaxial-line repeaters and, by feeding the power over the coaxial tubes themselves, it is possible to obviate the need for local power supplies at most of the intermediate repeater stations. Such stations are termed “auxiliary repeaters”; they are unattended, and in practice it is possible to have up to 10 such repeaters between power-feeding stations. Because so many circuits depend on coaxial systems, reliable standby power plant is needed, and it is customary to staff power-feeding stations which are, therefore, normally terminals and intermediate stations designated “main repeaters.” It is usual to apply the 60-kilocycle-pilot correcting circuits as well as 2604-kilocycle

control at these stations, and also to equip auxiliary equalisers. Also, since they are staffed, they are convenient stations at which to locate certain types of maintenance test gear.

The application of power to the coaxial cable at 650 volts involves the use of filters to separate the power and telephone-transmission paths, and also special interlocking protection devices to prevent handling the dangerous parts of the circuit while the power is on.

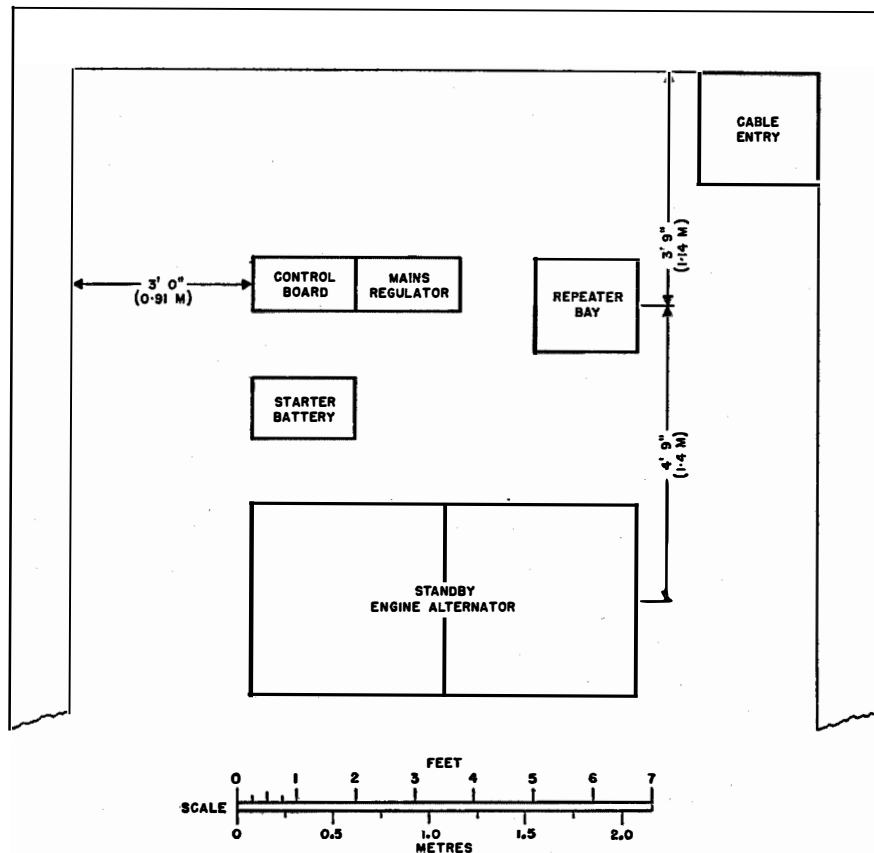

Fig. 9—Typical layout for main repeater station including standby power equipment.

2.5.4 Maintenance

To assist with interstation maintenance, two pairs of the interstice quads normally

laid up in the cable together with the coaxial tubes, are used to provide a supervisory speech circuit, and two other pairs are used for transmitting alarm conditions. The arrangement is shown in Fig. 7; faults indicated back to the control station include failure of power supply, deterioration of valves, and failure of 2604- and 60-kilocycle pilots. The bridge locating circuit enables the controlling station to identify the station from which the fault originates. In association with the above-mentioned supervisory facilities, specialised testing gear is also provided to maintain the system on a routine basis while it is in normal traffic operation or when faulty conditions occur.

2.5.5 Station Layout

Figs. 8A and 8B show typical station layouts for large and small coaxial terminals as indicated in the table. They include spare power cubicles for normal derivation of 21- and 130-volt direct-current supplies from the mains, but do not in-

clude spare standby plant for replacing the mains.

Fig. 9 shows a typical layout of a main repeater, and in this case the mains standby plant is included. The floor plan for an auxiliary repeater station is not shown, since this requires only one small bay of equipment, approximately 2-metres (6½-feet) high.

Various types of housing can be used for auxiliary repeater stations, including small metal-clad cupboards similar to lighting or tramway pillars which serve to enclose the bay.

The problem of housing equipment is nowadays of great importance because of the need for concentrating building materials and labour on the reconstruction of the large number of houses and other domestic buildings destroyed during the war. This problem has been aggravated by the lack of building during that period, and the result has been that considerably more attention has been paid to the reduction in size of equipment than would have been considered justified

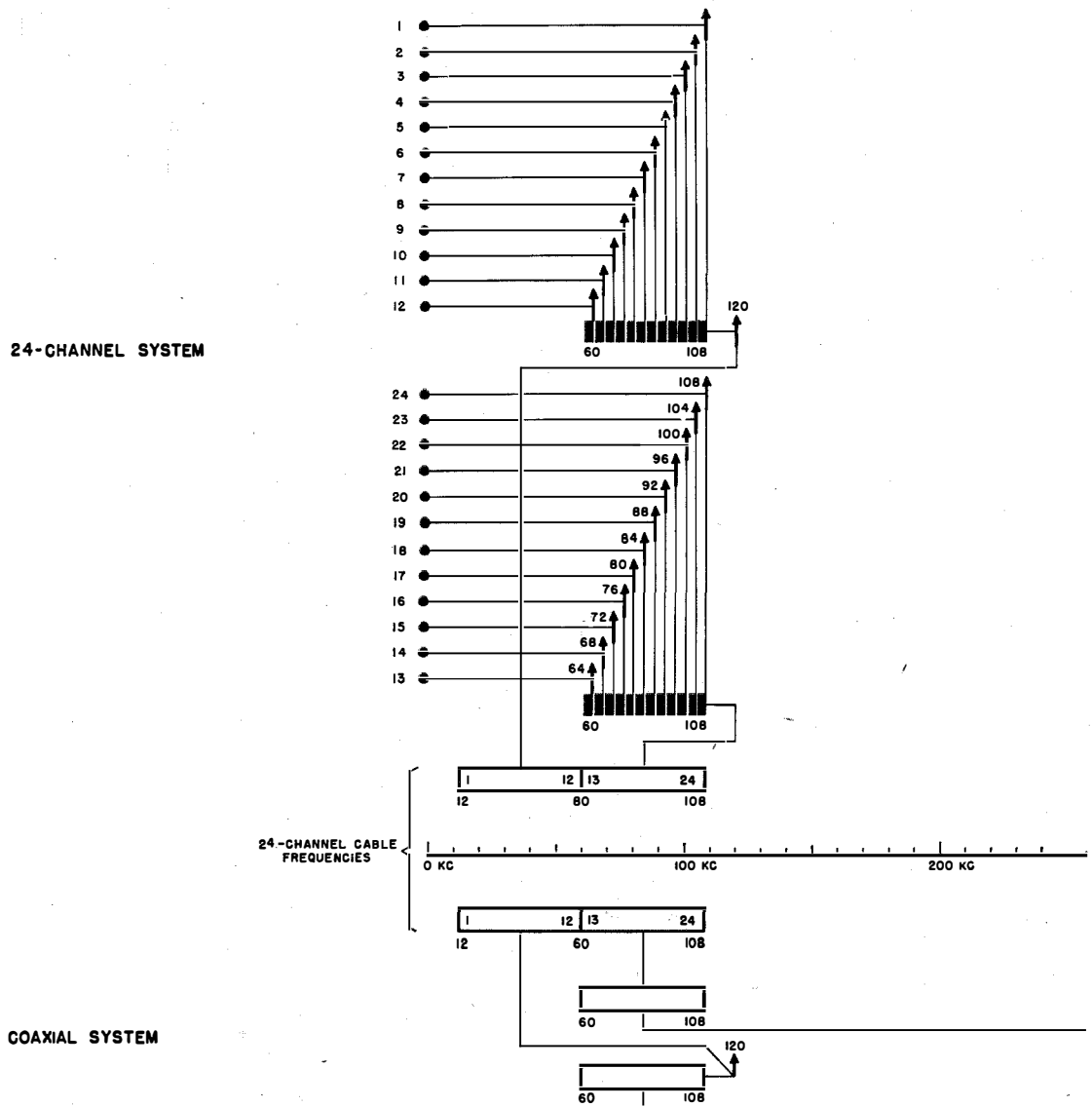
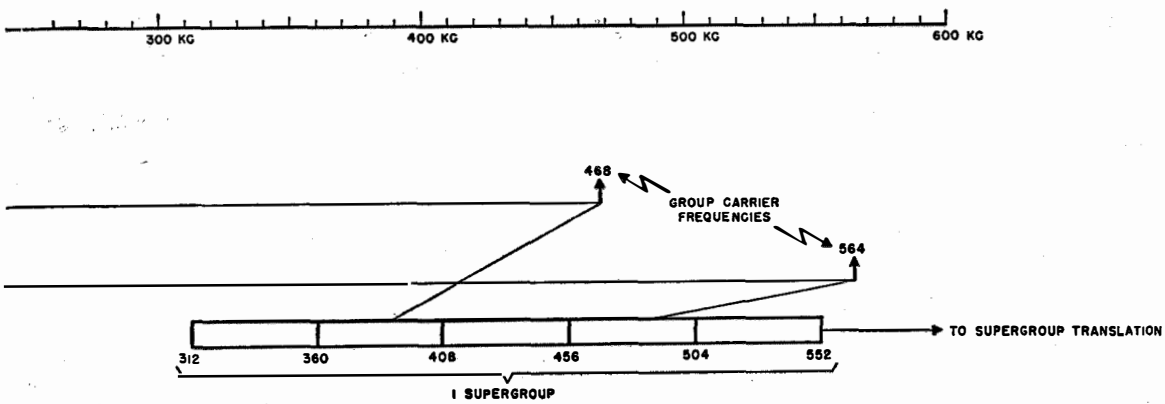

Fig. 10—Typical frequency allocation and routing of coaxial groups to 24-channel system.



in the past. It is naturally important that reduction in size should not be accomplished at the expense of performance, and studies therefore start with this as a requirement. The channelling equipment offers more scope for reduction in size, and this reduction is well on the way to fulfillment. As is shown here, the high-frequency part of the repeater represents so small a proportion of the whole, that reduction in size must apply to the power plant or supervision facilities. These can only be simplified at the expense of modifying requirements, so that for the present little change is foreseen.

2.6 INTERWORKING OF SYSTEMS

So far, the main methods of obtaining first-grade telephone circuits have been discussed, but an important aspect from the point of view of a telephone administration working to build up a network is the degree to which standardisation of apparatus, circuits and operating and maintenance practices can be obtained. To achieve a closely welded overall system, it is obviously desirable that blocks of channels, quality provided by each channel, guaranteed carrier-supply systems, etc., all conduce to this end.

It has already been pointed out that the systems discussed here use the basic 12-channel group in the 60–108-kilocycle frequency range, and that this group is used to build up 12-channel, 24-channel, and coaxial systems; and it is also used for the 12-channel open-wire carrier telephone system. All the channel band-pass filters that control the quality give a similar performance and are made in large quantities, thereby reducing manufacturing costs.

Fig. 10 shows how the frequency allocations of the 12-/24-channel systems, and the basic supergroup of the coaxial systems, permit flexibility and interworking. At junctions of multi-pair carrier systems, coaxial systems, or 12-channel open-wire systems, it is unnecessary to reduce channels to the voice-frequency range to interconnect on a group basis. Arrangements are made so that a coaxial terminal is normally broken down to the basic-group stage, and any such group is then available for routing at will (through a distribution frame) to the group stage of any of the following:

- A. 12-channel carrier-on-cable system.
- B. 24-channel carrier-on-cable system.
- C. 12-channel open-wire system.
- D. A second coaxial-cable system.
- E. A voice-frequency terminal.

In the case of *A* to *D*, it is necessary to include a filter between the two connected systems, as shown in Fig. 11.

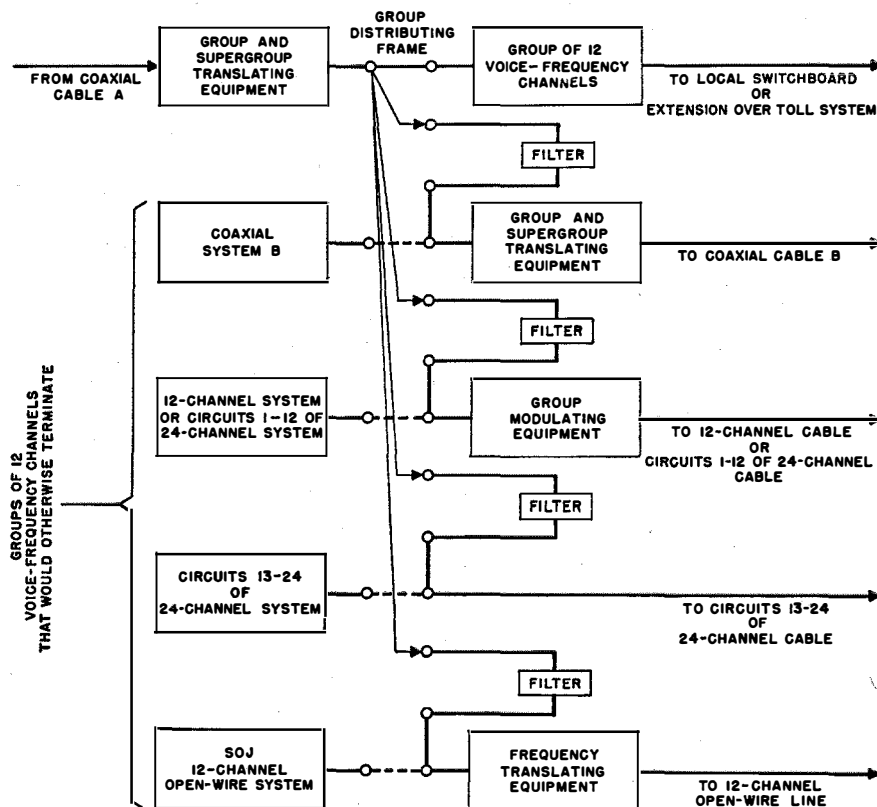

Fig. 11—Diagram illustrating alternative routing of a single coaxial group.

2.7 CARRIER ON DE-LOADED CABLES

There is no doubt, in our view, that for multi-pair carrier working, the straightforward 2-cable system is best and most economical. Occasions can arise, however, where for the time being, at any rate, it is considered essential to de-load and use an existing cable or cables. The case of two such cables used on a go-and-return basis in the normal manner has been already treated by A. J. Jackman and R. A. Seymour³. In the special case where it is necessary to utilise one cable for

transmission in both directions, the two directions are separated on a group-frequency basis, an untransposed basic group being transmitted in one direction and a transposed group in the other.

2.8 12-CHANNEL CARRIER USING SEPARATE PAIRS

In this arrangement, 12 channels in the 12-60-kilocycle range are transmitted on one side circuit of a quad, and 12 in the 60-108-kilocycle range are transmitted in the other direction on the other side circuit. This method avoids re-balancing the cable, and is really a near approach to the standardised system, since repeaters are straightforward and no directional or separating filters are needed. In practice, 24-channel-system amplifiers and equalisers may be used, and at a later date when an additional cable can be laid, the same repeater equipment may be employed to double the capacity of the route.

2.9 10-CHANNEL SYSTEM ON ONE PAIR

By this method, any pair that can be made suitable from a crosstalk-balancing point of view may be made to carry 10 channels in each direc-

³A. J. Jackman and R. A. Seymour, "Application of 12 Circuit Carrier Telephony to Existing Cables," *The Post Office Electrical Engineers' Journal*, v. 34, p. 169; April, 1941.

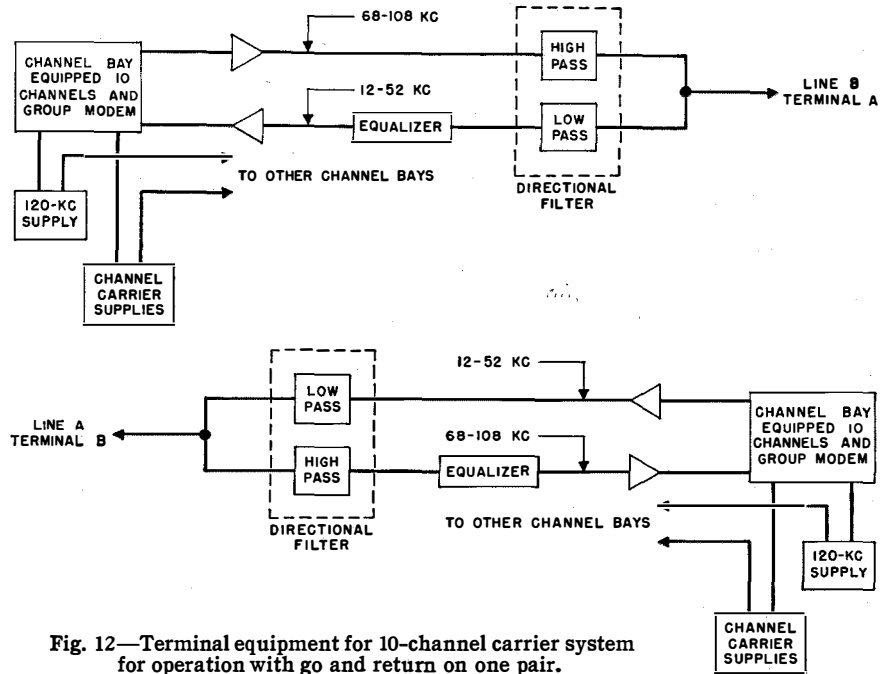

Fig. 12—Terminal equipment for 10-channel carrier system for operation with go and return on one pair.

tion. An arrangement of the terminals is shown in Fig. 12. At one terminal, the unmodulated basic group is reduced to 10 channels by dropping the channels between 60 and 68 kilocycles, and is transmitted through a high-pass filter to line. At the distant terminal this is received through a high-pass filter, an equaliser, and an amplifier. No group modulation is required.

In the other direction, the 10 channels occupying the range of 12-52 kilocycles, which have been transposed in the normal way, are transmitted and received through the low-pass directional filter. The normal through repeater is shown in Fig. 13. This must utilise two directional filters to separate the two directions of transmission. The gap between 52 and 68 kilocycles is necessary to obtain adequate crossover attenuation of the filters, and also to obtain suitable impedance matching of the channels near the cut-off—an important point on long systems of this type. Fig. 13 also shows a frequency-transposing repeater, which may be used at a junction point of three cables to co-ordinate the frequencies in the different directions of transmission.

Comparing this scheme with the normal 4-wire 24-channel system, i.e., working with two cables, the 10-channel system does not appear at an advantage. Based on an equal number of

channels, the 2-wire-system repeater is roughly about five times as expensive as the 24-channel-system repeater, because there are twice the number of amplifiers and equalisers (since only

channels can be carried by one amplifier, concerns what may be called auxiliary apparatus, notably that connected with power supply and supervision. In any multi-channel system, these

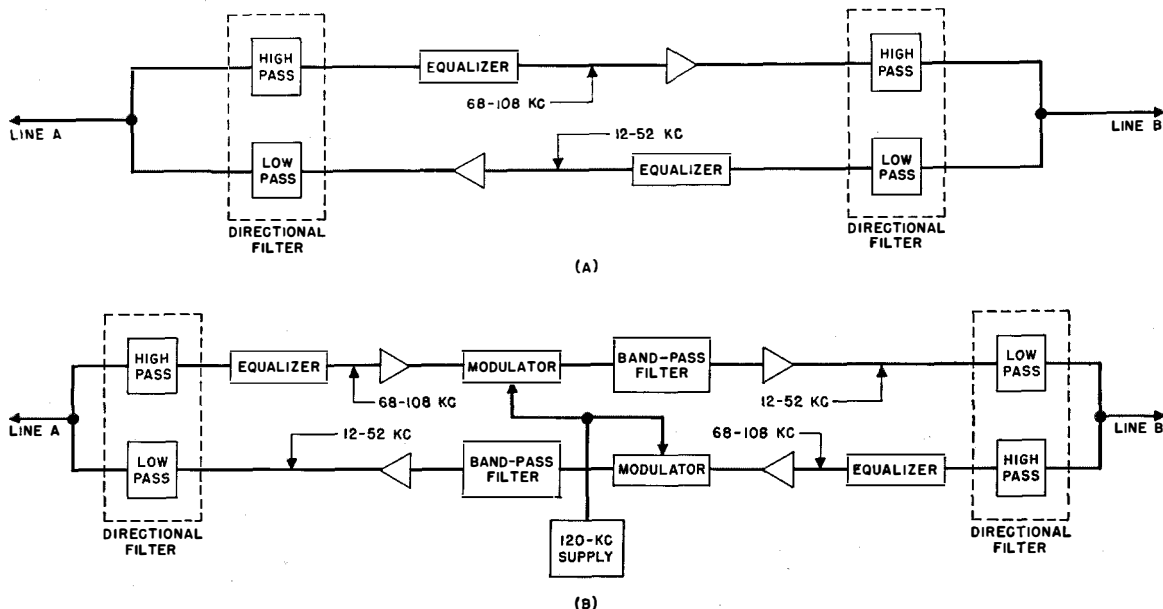

Fig. 13—(A)—Normal through repeater. (B)—Frequency-translating repeater for 10-channel carrier system for operation with go and return on one pair.

10 channels are amplified in a group), and there is also the additional cost of the directional filters. Since there are more than twice the number of amplifiers for the same number of circuits, the power requirements are correspondingly increased. The equipment may also be of the order of three times the bulk, and hence the building-space requirement is correspondingly greater. The cost difference at terminals is relatively small, so that the overall economics of the two systems depend on the number of circuits required, the cost of the second cable, and the length of the circuits, i.e., the relative preponderance in cost of repeaters over terminals and cable. The general disadvantage of the 10-channel 2-wire system is that eventually, when a more economical 4-wire arrangement is realised, the directional filters are of no further use. For this reason the arrangement described in Section 2.8 is to be preferred.

3. Power and Supervision

A point that becomes of major importance as equipment becomes smaller, and more and more

tend to occupy considerably more space than the high-frequency parts of the equipment, and so present problems to which careful thought has had to be given.

Since in a coaxial-cable system there must exist a cable, it seems reasonable to expect that the cable itself can be used for these purposes, and this, in fact, turns out to be the case.

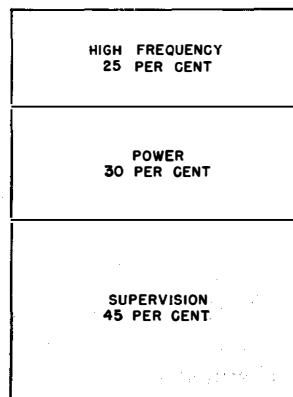

Fig. 14—Relative space occupancy of main divisions of coaxial repeater.

The power-supply problem is neatly solved by the transmission of power through the coaxial tubes themselves. The apparatus at the repeater station used in connection with power supply occupies approximately 30 per cent of the total volume of the repeater.

Supervision is a more difficult prob-

lem. When stations are unattended it is always necessary to provide means for indicating faults and for enabling visiting maintenance staff to converse between the station and the nearest control station. In the coaxial-cable system, by use of inexpensive pairs in the cable itself, supervision and maintenance circuits can easily be made available, but the volume occupied by these features in the coaxial repeater is approximately 45 per cent of the total.

Thus, as illustrated in Fig. 14, it will be seen that only 25 per cent of the volume of the repeater is occupied by the amplification and equalisation equipment. This point is stressed, as statements about the size of the repeater are frequently confused with statements about the size of the amplifier.

Only two types of fault indication are essential, and these can be designated urgent and non-urgent. Non-urgent faults can be dealt with at the time of the routine maintenance visit. (Presumably in the case of a cable there will always

be a suitable road or track along which a vehicle can move, but for all ordinary purposes a bicycle is probably all that is necessary for use in unattended-repeater-station maintenance.) The urgent-alarm indication shows that a special visit is necessary to a particular repeater station. It is, of course, necessary to know which unattended station should be visited, and this can readily be found in the case of coaxial systems, as described earlier.

Urgent indication would be given only on complete failure of the repeater, and adequate spares that are automatically inserted obviously reduce the probability of the urgent-alarm feature being used. Of course, a non-urgent alarm would be given when a spare had come into use.

4. Acknowledgment

I wish to thank my many colleagues who have helped in the preparation of this paper, and in particular, Mr. A. M. Thornton.

Evaluation of Transmission Efficiency According to Hartley's Expression of Information Content*

By A. G. CLAVIER

Federal Telecommunication Laboratories, Incorporated, Nutley, New Jersey

THE EFFICIENCY of any transmission system can be estimated as the ratio of the amount of information obtained in the reproduced message at the receiving end to the total amount of information that could have been transmitted theoretically in the propagation medium for the bandwidth and signal-to-noise ratio necessitated by the signals actually utilized. The amount of information is evaluated according to the expression given by R. V. L. Hartley for telegraphic signals, extended to the case of telephony and the presence of noise. The transmission efficiency thus defined is calculated for the main pulse-transmission systems (pulse-amplitude modulation, pulse-time modulation, pulse-count modulation, pulsed-frequency modulation) under certain assumptions. The various expressions obtained are helpful in the comparison between those systems, though it must not be overlooked that simplicity and cost of equipment will undoubtedly introduce other factors in the final choice for any given transmission problem.

. . .

1. General

To arrive at an evaluation of the amount of information conveyable through any type of transmission system, Hartley¹ started with the consideration of what would now be called pulse-amplitude-modulated (telegraphic) signals.

Let n_0 pulses be transmitted per second, each pulse having one of S discrete levels. The number of distinct sequences that can occur during a transmission time of t seconds is $S^{n_0 t}$. The measure of the amount of information that such a system is capable of transmitting is felt to be a

* Presented, New York Section, Institute of Radio Engineers, New York, New York, November 12, 1947.

¹R. V. L. Hartley, "Transmission of Information," *Bell System Technical Journal*, v. 7, pp. 535-563; July, 1928.

function of this number of sequences. Barring any analysis of the psychological content of the message, which these signals are meant to convey, it becomes intuitive that this measure should be proportional to the time during which the transmission takes place. This determines at once the type of function to be used, so that, according to Hartley, the measure of the amount of information the signals can convey is expressed by

$$H = k_0 \cdot \log S^{n_0 t} = k_0 \cdot n_0 \cdot t \cdot \log S,$$

k_0 being a constant that, together with the base of the logarithms used, defines the value of a conventional unit of information.

This definition is easily extended to the case of the n_0 pulses belonging to n_c separate channels. The pulses pertaining to any one channel are divided into n_r subframes per second, and each subframe in its turn includes n pulses or digits. It is obvious that the total amount of information is then

$$H = k_0 \cdot n_c \cdot n_r \cdot n \cdot t \cdot \log S,$$

and is thus equal to n_c times the amount of information assigned to any individual channel.

These signals, however, will have to be transmitted through a certain path, which may include wire transmission lines, lumped circuits, and radio links. A certain number of errors may be introduced during that transmission. These errors may result from a number of causes, some originating in the physical properties of the path itself, such as signal distortion and interference as well as from thermal noise. Others may come from outside, such as interference from other transmissions or atmospherics. Moreover, the number of errors may depend on meteorological factors, such as temperature and humidity, leading to fluctuating distortion or fading phenomena. To secure a sufficiently correct reproduction of the "message" at the receiving end, it will thus be necessary to adopt a minimum

value for the signal amplitude. If the limiting factor is thermal noise, it will establish a minimum signal-to-noise ratio at the receiving end for satisfactory communication. On the other hand, the type of signals and such properties of the transmission path as attenuation versus frequency and transmission delay or phase change versus frequency will determine the minimum frequency range or bandwidth for correct operation of the system.

The path over which the signals are transmitted will thus be characterized fundamentally by a minimum bandwidth and a minimum signal-to-noise ratio. An "ideal" type of "line" may be devised to serve as a basis for comparing different transmission systems. This ideal line will be endowed with the same bandwidth as the transmission path considered, but will present optimum properties as regards attenuation and phase response. That is to say, it will have a constant attenuation within its frequency range and infinite attenuation outside. The phase response will vary linearly with frequency within the bandwidth.

Such a line is, in effect, equivalent to an ideal low-pass filter with an abrupt cut-off frequency f_i . Any impulse of infinitely short duration but finite amplitude will produce a response proportional to

$$\frac{\sin 2\pi f_i \cdot t}{2\pi f_i \cdot t},$$

so that a series of such impulses separated by time intervals equal to $\frac{1}{2}f_i$ will generate independent instantaneous amplitudes which, theoretically at least, could be detected with negligible interference. However, the signal-to-noise ratio that must be used in the physical transmission path leads to a limitation on the number of separate levels that could otherwise be distinguished (those in the corresponding ideal line). Any signal amplitude S will be affected by noise; let \bar{N} be the root-mean-square value of this noise, supposedly of thermal origin, i.e., having the normal random distribution. The probability of the deviation of the received amplitude being larger than $\bar{N}\sqrt{2}$ is small, about 5 percent. Thus, if we adopt $\bar{N}\sqrt{2}$ as the difference between two signal levels, we should have a small percentage of error due to noise. The total number of distinguishable levels on the ideal

line is thus given by

$$\frac{S + \bar{N}\sqrt{2}}{\bar{N}\sqrt{2}} = 1 + \frac{S}{\bar{N}\sqrt{2}},$$

with a reasonable approximation. It follows that the amount of information transmittible on the ideal line is measured by

$$H_{im} = k_0 \cdot 2f_i \cdot t \cdot \log \left(1 + \frac{S_i}{\bar{N}_i\sqrt{2}} \right).$$

It is suggested that the efficiency of the transmission system under examination be evaluated as the ratio of the amount of information recovered in the received message to this quantity H_{im} , which is the maximum amount of information that can be transmitted on the corresponding ideal line.

In the case of telephony, however, the received message will generally consist of a continuous curve of amplitude versus time. This curve will be limited in frequency range; let f_m be the upper limit of this frequency band. It can be observed that, should this curve be sampled by means of equally spaced pulses at a rate of $2f_m$ per second, the amount of information contained in the series of pulses would be the same as for the continuous curve, since this latter curve could be extracted from the pulses by means of an ideal filter, and no other process would lead to any larger amount of information. Let S_m and \bar{N}_m be the message amplitude and root-mean-square value of the message noise, respectively. The amount of information in the message is thus

$$H_m = k_0 \cdot 2f_m \cdot t_m \cdot \log \left(1 + \frac{S_m}{\bar{N}_m\sqrt{2}} \right).$$

According to the previous definition, the transmission efficiency of the system considered will be

$$\eta = \frac{H_m}{H_{im}} = \frac{f_m t_m \log \left(1 + \frac{S_m}{\bar{N}_m\sqrt{2}} \right)}{f_i t_i \log \left(1 + \frac{S_i}{\bar{N}_i\sqrt{2}} \right)}.$$

It should be observed, however, that it is assumed here that the object of the transmission system is to reproduce with fidelity a continuous curve of amplitude versus time. No account is taken of the particular properties of the ear as the ultimate organ to be acted on, and all the

following considerations suffer from that limitation.

The expression for η shows at once that all systems for which, in the ideal line, the product $f_i \cdot t_i$ remains constant and the signal-to-noise ratio unaltered, have the same efficiency. There can thus be an interchange between bandwidth and transmission time. A simple instance is the recording of a message to be transmitted, this record then being delivered to the line at a different speed from the recording speed.

Those systems for which $t_m = t_i$, as well as $f_m = f_i$, and $S_m/\bar{N}_m = S_i/\bar{N}_i$, have 100-percent efficiency. This is the case for single-sideband transmission over one message channel. When single-sideband transmission is used for a number of channels transposed in frequency (utilizing the so-called frequency-division method, as opposed to time division), the necessary line bandwidth is increased by the amount required for the separation of the different message channels by band-pass filters. This lowers the efficiency to about 85 percent when quartz filters of modern design are utilized.

The most prominent transmission systems are analyzed below in the light of the foregoing considerations. Frequency modulation (FM), pulse-time modulation (PTM), pulse-count modulation (PCM), pulse-amplitude modulation (PAM), and pulsed-frequency modulation (PFM) are included. It is assumed in all cases that a high signal-to-noise ratio is required for the message, and a value of 60 decibels has been chosen as being conventional.

2. Frequency-Modulation Systems

Frequency modulation is too well known to require any description. Let n_c channels be transmitted simultaneously, the frequency range of each channel being f_m . The information in the reproduced message will be

$$H_m = 2k_0 \cdot n_c \cdot f_m \cdot t \cdot \log \left(1 + \frac{S_m}{\bar{N}_m \sqrt{2}} \right).$$

The ideal-line characteristics are easily determined. The modulation frequency range will be somewhat greater than $n_c \cdot f_m$, say, $1.2n_c \cdot f_m$ as explained above, to allow for separation of the channels by means of filters. Let m be the modulation index. The minimum line-bandwidth

for acceptable distortion is generally considered to be

$$2(m+1) \times 1.2n_c \cdot f_m.$$

The information content transmittible over the line will be

$$H_{im} = 4k_0(m+1) \times 1.2n_c \cdot f_m \cdot t \cdot \log \left(1 + \frac{S_i}{\bar{N}_i \sqrt{2}} \right),$$

resulting in the following expression for the transmission efficiency:

$$\eta = \frac{1}{2.4(m+1)} \frac{\log \left(1 + \frac{S_m}{\bar{N}_m \sqrt{2}} \right)}{\log \left(1 + \frac{S_i}{\bar{N}_i \sqrt{2}} \right)}.$$

Now the relation between signal-to-noise ratios for the message and the line is known to be

$$\frac{S_i}{\bar{N}_i \sqrt{2}} = \frac{1}{m\sqrt{3}} \frac{S_m}{\bar{N}_m \sqrt{2}}.$$

This relation holds as long as $S_i/\bar{N}_i\sqrt{2}$ is sufficiently greater than 1 (say, 3), so that the signal remains above the so-called frequency-modulation threshold. As we assume $20 \log (S_m/\bar{N}_m\sqrt{2})$ to be equal to 60; this means that the validity of the expression for η is limited to values of m smaller than $1000/3\sqrt{3}$, or 192.

Up to a value of $m=100$, the units under the logarithms can be neglected without appreciably altering the results, so that

$$\eta = \frac{1.25}{(m+1)(2.76 - \log m)}.$$

The results are shown in Table 1.

TABLE 1
TRANSMISSION EFFICIENCY FOR FREQUENCY-MODULATION SYSTEMS

m	η	m	η
1	0.23	7	0.080
2	0.17	8	0.075
3	0.14	9	0.070
4	0.12	10	0.065
5	0.10	50	0.020
6	0.09	100	0.016

3. Pulse-Time-Modulation Systems

For pulse-time modulation, the signals constitute a series of pulses which, in the absence of modulation, are of equal height, equal width, and equally spaced in time. This series is di-

vided into n_c interlaced subseries, n_c being the number of channels. With the introduction of modulation, each pulse is displaced in time proportionally to the instantaneous amplitude of the modulating message. Means are provided at the receiving end to separate the subseries and convert the time modulation back into the original continuous curve of amplitude versus time that constituted the message.²

The message information content per channel is, therefore,

$$H_m = 2k_0 \cdot f_m \cdot t \cdot \log \left(1 + \frac{S_m}{\bar{N}_m \sqrt{2}} \right).$$

The ideal-line characteristics are determined as follows.

The frequency range will be such as to keep the interference between any one pulse and those following less than the difference between two distinguishable levels on the line.

Let τ be the pulse duration and $\pm d$ be the maximum time displacement; the number of channels is

$$n_c = \frac{1}{2f_m \tau \left(1 + \frac{2d}{\tau} \right)}.$$

To simplify, no account is taken of any marking pulse inserted for the separation of the channels.

The relation between the signal-to-noise ratios in the message and the line is found to be²

$$\frac{S_m}{\bar{N}_m \sqrt{2}} = \frac{d}{g} \frac{S_l}{\bar{N}_l \sqrt{2}},$$

g being the rise time of the signal, which is supposed to be approximately trapezoidal. A reasonable assumption is $g = \tau/2$. Then,

$$\frac{S_l}{\bar{N}_l \sqrt{2}} = \frac{\tau}{2d} \frac{S_m}{\bar{N}_m \sqrt{2}}.$$

In the following, d/τ will be kept under a value that will bring $S_l/\bar{N}_l \sqrt{2}$ below 3 (i.e., $d/\tau < 166$). Let this quantity be called m , and a value of 60 decibels be assumed for the message signal-to-noise ratio. The units under the logarithms in the expression for η can be neglected.

Let the bandwidth of the line be called B ; then finally,

$$\eta = \frac{1}{2B\tau(2m+1)} \frac{\log \frac{S_m}{\bar{N}_m \sqrt{2}}}{\log \frac{1}{2m} \frac{S_m}{\bar{N}_m \sqrt{2}}}.$$

The quantity $B\tau$ can now be determined with the condition of limited interference between successive pulses, assuming an exponential law for the attenuation of the signal with time on the line and a time constant of $1/\pi B$:

$$e^{\pi B\tau} \gg \frac{1}{2m} \frac{S_m}{\bar{N}_m \sqrt{2}},$$

$$B\tau = \frac{2.3}{\pi} \log \frac{1}{2m} \frac{S_m}{\bar{N}_m \sqrt{2}}.$$

For a message signal-to-noise ratio equal to 60 decibels, the transmission efficiency is expressed by

$$\eta = \frac{2}{(2m+1)(2.7 - \log m)^2}.$$

The results are shown in Table 2, which gives values for η when $g = \tau/2$ and $\tau/3$.

TABLE 2
TRANSMISSION EFFICIENCY FOR PULSE-TIME-MODULATION SYSTEMS

m	$\left(\frac{\eta}{g=\tau/2} \right)$	$\left(\frac{\eta}{g=\tau/3} \right)$	m	$\left(\frac{\eta}{g=\tau/2} \right)$	$\left(\frac{\eta}{g=\tau/3} \right)$
0.5	0.11	0.13	6	0.042	—
1	0.09	0.11	7	0.039	—
2	0.07	—	8	0.036	—
3	0.057	—	9	0.034	—
4	0.050	0.06	10	0.023	0.04
5	0.045	—			

4. Pulse-Count-Modulation Systems

Pulse-count modulation, as first described by A. H. Reeves in United States and French patents,³ makes use of three successive operations: sampling, quantizing of the sampled amplitudes, and transmission of the quantized amplitudes by means of a code similar to that utilized at the beginning of this paper to introduce Hartley's method of measuring the amount of information conveyable in transmission systems. Quantizing means that the amplitude range of the modulating signal is divided into a finite

² E. M. Deloraine and E. Labin, "Pulse Time Modulation," *Electrical Communication*, v. 22, n. 2, pp. 91-98; 1944.

³ A. H. Reeves, United States patent 2,272,070; February 3, 1942. French patent 852,183; October 23, 1939.

number of discrete levels. Any sampled amplitude will fall between two successive levels; only that level closer to the actual signal amplitude is transmitted.⁴⁻⁶

Let m be the number of levels used; the message information content, where n_c channels are transmitted, is

$$H_m = 2k_0 \cdot n_c \cdot f_m \cdot t \cdot \log m,$$

f_m being the frequency range of each individual channel.

Let the code comprise ν digits, each having s discrete values. This means that the number of levels is $m = s\nu$. The minimum bandwidth for the line can be shown⁴ to be $\nu n_c f_m$, so that the transmission efficiency is

$$\eta = \frac{1}{\nu} \frac{\log m}{\log \left(1 + \frac{S_l}{\bar{N}_l \sqrt{2}} \right)}$$

As $\nu = \log m / \log s$, the transmission efficiency can also be written

$$\eta = \frac{\log s}{\log \left(1 + \frac{S_l}{\bar{N}_l \sqrt{2}} \right)}$$

When the code used is binary, $s = 2$, the relation between signal-to-noise ratio in the line and message can be shown to be

$$20 \log \frac{S_m}{\bar{N}_m \sqrt{2}} = 2.2 \left(\frac{S_l}{\bar{N}_l \sqrt{2}} \right)^2,$$

provided the number of digits in the code is sufficiently large, exceeding, say, 3 or 4.

Assuming that, as for the systems previously considered, a signal-to-noise ratio of 60 decibels is required for the message, the transmission efficiency of pulse-count-modulation systems is found to be approximately 0.4, and is independent of the number of digits in the code provided it is larger than 3 or 4.

This means that whatever the amount of distortion specified for the reproduced message (which determines the number of levels m) may be, the pulse-count-modulation transmission effi-

ciency, as defined in the text, remains the same for a binary system of coding.

5. Pulse-Amplitude-Modulation Systems

With pulse-amplitude modulation transmitted over a line where transient response varies exponentially with time, and assuming n_c channels to be transmitted, each f_m cycles wide, the line bandwidth B will be conventionally determined by limiting to less than the minimum distinguishable level $\bar{N}_l \sqrt{2}$ the effect of interference produced by a pulse of maximum amplitude on a succeeding pulse.

This gives

$$e^{\pi B \tau} = \frac{S_l}{\bar{N}_l \sqrt{2}},$$

τ being the pulse duration, equal to $\frac{1}{4} n_c f_m$.

The relation between signal-to-noise ratios in message and line is, for full modulation,

$$\frac{S_l}{\bar{N}_l \sqrt{2}} = 2 \left(\frac{f_m}{B} \right)^{\frac{1}{2}} \frac{S_m}{\bar{N}_m \sqrt{2}},$$

so that B/f_m is determined by

$$\frac{1}{N_c} \cdot \frac{B}{f_m} = \frac{3.2}{\pi} \log \left[2 \left(\frac{f_m}{B} \right)^{\frac{1}{2}} \frac{S_m}{\bar{N}_m \sqrt{2}} \right].$$

Once B/f_m is found, the transmission efficiency can be calculated according to definition:

$$\eta = \frac{3.2}{\pi} \left(\frac{n_c f_m}{B} \right)^2 \log \frac{S_m}{\bar{N}_m \sqrt{2}}.$$

Let the message signal-to-noise ratio be 60 decibels as before; the two equations giving B/f_m and η are

$$\begin{aligned} \frac{1}{n_c f_m} \frac{B}{f_m} &= \frac{3.2}{\pi} \left(3.3 - 0.5 \log \frac{B}{f_m} \right), \\ \eta &= \frac{27.6}{\pi} \left(\frac{n_c f_m}{B} \right)^2. \end{aligned}$$

The results are listed in Table 3. The number of channels has been limited to a value for

TABLE 3
TRANSMISSION EFFICIENCY FOR PULSE-AMPLITUDE-MODULATION SYSTEMS

n_c	B/f_m	$B/n_c f_m$	η
1	8.3	8.3	0.13
20	130	6.5	0.21
50	300	6.0	0.24
100	555	5.5	0.28
400	1950	4.9	0.37

⁴ D. D. Grieg, "Pulse-Count Modulation," *Electrical Communication*, v. 24, pp. 287-296; September, 1947.

⁵ H. S. Black and J. O. Edson, "PCM Equipment," *Electrical Engineering*, v. 66, pp. 1123-1125; November, 1947.

⁶ W. M. Goodall, "Telephony by Pulse Code Modulation," *Bell System Technical Journal*, v. 26, pp. 395-409; July, 1947.

which the signal-to-noise ratio in the line remains large enough to allow for substantially 100-percent modulation.

6. Pulsed-Frequency-Modulation Systems

By pulsed-frequency modulation is meant a system utilizing a series of pulses of equal height, equal width, with fixed position in time, and the information being transmitted by frequency modulating the high-frequency carrier wave.

The required line bandwidth is then approximately

$$B_0 + 2(m + 1)f_m,$$

B_0 being the additional bandwidth needed for the correct transmission of the pulse shape, m the frequency-modulation index, f_m the bandwidth of each of the n_c channels being transmitted.

This necessitates the separation of the channels before frequency discrimination takes place.

The relation between signal-to-noise ratios in message and line is assumed to be the same as for standard frequency modulation;

$$\frac{S_l}{N_l \sqrt{2}} = \frac{1}{m \sqrt{3}} \frac{S_m}{N_m \sqrt{2}}.$$

The extra bandwidth B_0 is determined by the fact that the interference caused by one pulse on the following should be less than the effect of noise. Assuming that 60 decibels are required for the message signal-to-noise ratio, this means that

$$20 \log e^{\pi B_0 \tau} \geq 60,$$

τ being the pulse duration.

This gives

$$B_0 \tau \geq 2.2.$$

TABLE 4

TRANSMISSION EFFICIENCY FOR PULSED-FREQUENCY-MODULATION SYSTEMS

m	Transmission Efficiency η			
	$n_c = 1$	$n_c = 20$	$n_c = 100$	$n_c = 400$
1	0.08	0.12	0.12	0.12
5	0.07	0.15	0.16	0.16
10	0.06	0.17	0.19	0.19
50	0.023	0.20	0.29	0.31
100	0.020	0.21	0.36	0.42

Taking the lower limit, the expression for the transmission efficiency is found to be

$$\eta = \frac{1}{8.8 + 2 \frac{(m+1)}{n_c}} \frac{3}{2.76 - \log m}.$$

The results are tabulated in Table 4 for various numbers of channels. In all cases, the frequency-modulation index should, of course, remain under a value leading to a signal-to-noise ratio so low that the relation between signal-to-noise ratios in message and line is no longer valid.

7. Conclusions

The foregoing examples give sufficient illustration of the usefulness of the transmission-efficiency coefficient as defined, together with its limitations. It will be seen that frequency modulation and pulse-time modulation behave in a very similar way; the transmission efficiency decreases as the bandwidth used for the same overall modulating bandwidth is increased. This is obvious when it is recalled that the transmission efficiency is nothing more, in this case, than the product of the ratio of bandwidths in message and line by the ratio of signal-to-noise ratios in message and line, the second factor being expressed in decibels. The increase in bandwidth is not sufficiently compensated for by the decrease in decibels of the signal-to-noise ratio in the line. This should not be interpreted to mean that an increase in bandwidth should not be considered for such transmission systems, as the gains in signal-to-noise ratio in the line may well be the decisive factor, as, for instance, in the case of radio links where a reduction in transmitter output is generally a very desirable feature.

Pulse-count modulation is shown to have a higher transmission efficiency than the previously mentioned systems. It should be noted, however, that the apparent constancy of this factor for various numbers of digits in the code tends to mask the fact that the amount of information in the received message is not transmitted with equal accuracy for these different codes. The distortion introduced by the quantization process depends on the number of digits used. Should it be required that the distortion be of the same

order as the noise tolerated in the message (that is, 60 decibels below signal level), it can be shown that the number of digits should be approximately 11. Fewer digits will give higher distortion, but this can be tolerated in many cases, although the noise should remain at a much lower level to avoid its being bothersome during intervals between speech. A higher number of digits would be unnecessary, unless a higher signal-to-noise ratio is to be achieved in the message.

The last two modulation methods have been included to show that an increase in bandwidth may lead to an increase in transmission efficiency, contrary to what happens for frequency modulation and pulse-time modulation. This is the case for pulse-amplitude modulation with the assumptions made; other considerations, such as fading phenomena on radio links, will often rule out this kind of modulation. Pulsed-frequency modulation appears to be quite favorable when the transmission of a great number of channels is considered, provided the circuitry involved does not prove to be uneconomical.

On the other hand, this same system would not be suitable for transmitting a message occupying a large bandwidth in itself.

It should not be overlooked that transmission efficiency as defined is just one factor among many involved in the choice of a communication system to meet specific requirements. Prevalence of bandwidth considerations over signal-to-noise ratios, or *vice versa*, simplicity and reliability of equipment, both at transmitter and receiver, number of repeaters, degree of privacy required, cost of manufacture and maintenance; all of these are significant and cannot be included in an oversimplified factor of merit such as transmission efficiency.

There is, perhaps, no better conclusion than to quote Hartley, who stated,¹

It will, of course, be found that in very many cases it is not economically practical to make use of the full physical possibilities of a system. A criterion is, however, often useful for estimating the possible increase in performance which may be expected to result from improvement in apparatus or circuits, and also for detecting fallacies in the theory of operation of a proposed system.

Recent Telecommunication Developments

CREED NO. 47 TAPE TELEPRINTER—Plans have been initiated for converting the British Inland Telegraph service to fully automatic switching. The introduction of nationwide automatic switching is also contemplated by the

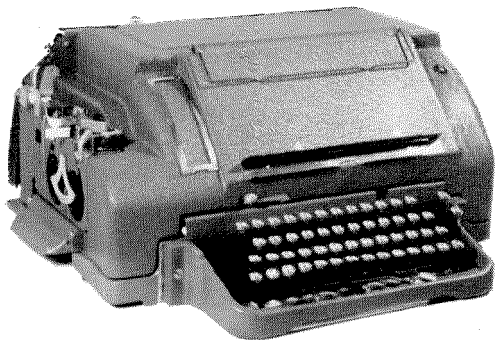

telegraph administrations of France, Holland, Belgium, and Denmark.

For such services to be economically successful, the teleprinters must not require operators in constant attendance. No time must be lost in receiving an answer to an incoming call or in confirming that a message has been correctly received. It must also be possible to transmit to any teleprinter with complete assurance that connection with the correct office has been made, that its printer is in a condition to receive traffic, and that there is an ample supply of paper tape that is feeding correctly. The teleprinters must also be capable of long periods of heavy service with minimum attention. To meet these needs, Creed and Company has introduced a new tape-model teleprinter, which embodies those units of the No. 7 page model that have proved entirely dependable under the most arduous conditions. Many novel features, which make this new machine particularly suitable for use in automatic switching networks, have also been included.

An "answer-back" unit provides confirmation that the correct office has been contacted.

The typewriter ribbon and roll of paper tape can be renewed without removing the printer cover or stopping transmission. The location of the printing point and of the tape tear-off position ensures good visibility and ease in handling incoming traffic. Should the paper tape break, become expended, or fail to feed forward, a tape alarm gives positive warning immediately and transmission is interrupted.

An orientation device, in association with high-grade signals from the striker transmitter fitted to the keyboard, furnishes a ready means of testing the operating margin of the instrument.

Maintenance is facilitated by unit construction and a lubrication system permitting over 300 hours continuous operation without attention.

A four-row keyboard can be supplied and incorporates a shift-lock mechanism as a safeguard against failure to operate the "figure" and "letter" shift keys. A three-row keyboard with double character keys or a commercial typewriter keyboard with automatic "case" change mechanism can also be provided.

A message tray may be used. It incorporates a station indicator and provides convenient means for the separation and storage of incoming and outgoing traffic.

The dimensions of the printer makes it well suited for use at manual switching positions.

• • •

ETCHINGS OF ERLANG—The Bureau de l'Union Internationale des Telecommunications published in 1935 the first of a series of etchings of noted contributors to the telecommunication sciences and arts. There has recently been added to this series a portrait of Agner Krarup Erlang.

Erlang is widely recognized for his mathematical work in the field of telephony, which is perhaps best epitomized by his formula for the distribution of telephone waiting times. Although most of his professional life was spent during the opening decades of the twentieth century with the Copenhagen Telephone Company, his interests were not restricted to telephony but embraced physics and electricity and among the arts, philosophy, history, and poetry.

All etchings in the series are still available from the Bureau at Effingerstrasse 1, Berne, Switzerland at 3 Swiss francs each, including mailing and packing. The etchings including margins are 23 by 17 centimeters (9 by 6 $\frac{3}{8}$ inches) on luxury paper. Portraits of the following may be ordered: Ampère, Baudot, Bell, Erlang, Ferrié, Gauss and Weber, Hertz, Hughes, Marconi, Maxwell, Morse, Popov, and Siemens.

In Memoriam



JOHN EDWARD KINGSBURY

JOHN EDWARD KINGSBURY died on November 4, 1948. At the time of his death in his 94th year, he was the oldest man in the world who had been concerned with the development of the telephone. He had been associated with many telephone pioneers including Alexander Graham Bell.

In 1883, Mr. Kingsbury opened a small office in London as the representative of the Western Electric Company. From this modest beginning was developed Standard Telephones and Cables, Limited, an associate company of the International Telephone and Telegraph Corporation.

Telephone equipment and exchanges were supplied and installed for the National Telephone Company and other companies. In 1897, he was instrumental in purchasing the North Woolwich works of Fowler Waring Cable Company, which is still a manufacturing unit of the Standard

organization. Mr. Kingsbury retired from active management in 1906 but continued until 1925 as a director of Western Electric Company Limited. He was also actively associated with Damard Lacquer Company and with Bakelite Limited, with which the former company was merged.

Mr. Kingsbury joined the Society of Telegraph Engineers in 1887 and played an active part in developing that organization into the Institution of Electrical Engineers. He served as vice president, honorary treasurer, and as a member of the council of the Institution between 1900 and 1920.

His exhaustive treatise, "The Telephone and Telephone Exchanges—Their Invention and Development" was first published in 1915 and is still consulted as a standard work.

Contributors to This Issue



RICHARD F. CLEAVER

RICHARD F. CLEAVER was born near Liverpool, England, on July 12, 1912. He received the B.Sc. (Eng.) and M.Sc. (Eng.) degrees from Owens College in the University of Manchester in 1933 and 1934.

He joined the radio division of Standard Telephones and Cables Limited in London in 1934 and has specialized in radio direction finding. Until the outbreak of the recent war, he worked on medium and high-frequency manual direction finders for use at aeronautical ground stations, spending considerable time in South Africa on installation and experimental work in the field. Since

1939, he has worked mainly on the development of automatic direction-finding systems.

Mr. Cleaver is an Associate Member of the Institution of Electrical Engineers.

• • •

DAVID L. HOLLWAY was born at Ballarat, Victoria, Australia, in December, 1915. At Melbourne University, he received the B.E.E. degree in 1937 and the M.Eng.Sc. degree in 1939.

From 1940 to 1946, he served in the valve division of Standard Telephones and Cables Pty., Limited, handling engineering problems in the production of receiving, transmitting, and radar vacuum tubes.

In July, 1946, he joined the staff of the Electrotechnology Division of the National Standards Laboratory of the Council for Scientific and Industrial Research, where he is at present engaged in work on ultra-high-frequency measurements.

Mr. Hollway is an Associate Member of the Institution of Engineers, Australia, and of the Institution of Radio Engineers, Australia.

• • •

GEORGE LEWIS was born in Media, Pennsylvania, on September 15, 1887. He attended St. John's College and Columbia University.

From 1910 to 1912, he served as a radio engineer in the U. S. Army Signal Corps. In 1912, he became an expert radio aide in the U. S. Navy, rising to the rank of Commander. In 1922 he joined the Crosley Radio Corporation as assistant to the president. He served as vice president and general manager of the Ken-Rad Corporation from 1925 to 1927 and filled similar positions in the Arcturus Radio Corporation from 1927 to 1935.

He joined the engineering staff of International Telephone and Telegraph Corporation in 1935 and is now an assistant vice president of that organization and of the Federal Telephone and Radio Corporation.



GEORGE LEWIS

Mr. Lewis is a member of the Institute of Radio Engineers, Engineers' Club, Radio Club of America, and the Annapolis Yacht Club.

• • •

F. J. MANN was born in Hoboken, New Jersey, on April 27, 1906. He received the B.S. degree from Middlebury College in 1933. Postgraduate studies were in communications and journalism, the latter at Columbia University School of Journalism.

From 1925 to 1927, he was on the staff of *Radio Broadcast* magazine. In 1928, he was appointed radio editor of

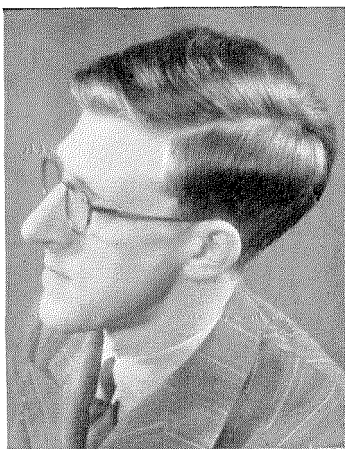

DAVID L. HOLLWAY



F. J. MANN

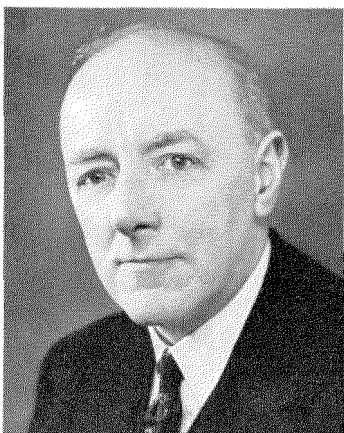

ALEXANDER W. MONTGOMERY

Science and Invention. He served as a marine radio operator before completing college and after his post-graduate work he became a radio operator at broadcast station WCAX in Burlington, Vermont. From 1934 to 1940, he was engaged in newspaper work and freelance writing. Mr. Mann then became assistant to the director of technical publications of Bendix Radio.

Joining the *Electrical Communication* staff as a writer in 1942, he is now manager of the Technical Publications Division of I.T.&T., managing editor of *Electrical Communication*, and editor of the handbook, *Reference Data for Radio Engineers*.

• • •

ALEXANDER WILLIAM MONTGOMERY received the B.Sc. Tech. degree from Manchester College of Technology after having served for four years with the army during World War I.

In 1921, he joined the Western Electric Company in London and became closely associated with the early development in Great Britain of repeaters and carrier systems. He was active also in the field of voice-frequency telegraphy. He is now technical director of Standard Telephones and Cables, Limited, and managing director and director of research of Standard Telecommunication Laboratories, Limited. During World War II, he was actively engaged on the development of the British defense teleprinter network and of a wide range of communication equipment. He served on a number of government committees and, in 1944, visited the U.S.A. as a member of a Ministry of Supply mission. For his war work, he was made an Officer of the Order of the British Empire.

For many years, Mr. Montgomery has been prominently identified with both the Comité Consultatif International Téléphonique and Comité Consultatif International Télégraphique, and represents the British telecommunications industry on a number of government and other committees.

He is a Member of the Institution of Electrical Engineers and of the American Institute of Electrical Engineers, and a Senior Member of the Institute of Radio Engineers.

• • •

NORMAN H. YOUNG was born in Philadelphia, Pennsylvania, in 1913. He received the B.S. degree in electrical engineering from Pennsylvania State College in 1934 and the M.S. degree in 1935.

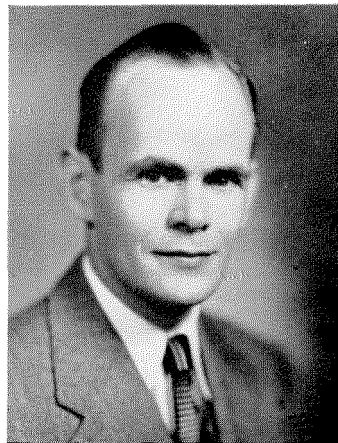

NORMAN H. YOUNG

From 1935 to 1942, he was engaged in television engineering for the Philco Corporation and had charge of the transmitter of television station WPTZ.

In 1942 he became a department head in Federal Telecommunication Laboratories and during the war was largely concerned with the application of pulse-time modulation to military communication equipment. At the termination of the war, he was responsible for the engineering of the color-television transmitter for the Columbia Broadcasting System. He has done additional work on receivers and studio equipment for color television.

Mr. Young is a member of Eta Kappa Nu and a Senior Member of the Institute of Radio Engineers.

• • •

For a biography and photograph of A. G. Clavier, see v. 25, p. 206; June, 1948.

INTERNATIONAL TELEPHONE AND TELEGRAPH CORPORATION

Associate Manufacturing and Sales Companies

United States of America

International Standard Electric Corporation, New York, New York
Federal Telephone and Radio Corporation, Newark and Clifton, New Jersey
International Standard Trading Corporation, New York, New York

Great Britain and Dominions

Standard Telephones and Cables, Limited, London, England
Branch Offices: Birmingham, Bristol, Leeds, Manchester, England; Glasgow, Scotland; Dublin, Ireland; Cairo, Egypt; Calcutta, India; Johannesburg, South Africa
Creed and Company, Limited, Croydon, England
International Marine Radio Company Limited, Liverpool, England
Kolster-Brandes Limited, Sidcup, England
Standard Telephones and Cables Pty. Limited, Sydney, Australia
Branch Offices: Melbourne, Australia; Wellington, New Zealand
Silovac Electrical Products Pty. Limited, Sydney, Australia
Austral Standard Cables Pty. Limited, Sydney, Australia
New Zealand Electric Totalisators Limited, Wellington, New Zealand
Federal Electric Manufacturing Company, Ltd., Montreal, Canada

South America

Compañía Standard Electric Argentina, Sociedad Anónima, Industrial y Comercial, Buenos Aires, Argentina
Standard Electrica, S.A., Rio de Janeiro, Brazil
Compañía Standard Electric, S.A.C., Santiago, Chile

Europe and Far East

Vereinigte Telephon- und Telegraphenfabriks Aktien-Gesellschaft Czeizler, Nissl and Company, Vienna, Austria
Bell Telephone Manufacturing Company, Antwerp, Belgium

China Electric Company, Limited, Shanghai, China
Standard Electric Aktieselskab, Copenhagen, Denmark
Compagnie Générale de Constructions Téléphoniques, Paris, France
Le Matériel Téléphonique, Paris, France
Les Téléprimeurs, Paris, France
Lignes Télégraphiques et Téléphoniques, Paris, France
Ferdinand Schuchhardt Berliner Fernsprech- und Telegraphenwerk Aktiengesellschaft, Berlin, Germany
Lorenz, C., A.G. and Subsidiaries, Berlin, Germany
Mix & Genest Aktiengesellschaft and Subsidiaries, Berlin, Germany
Süddeutsche Apparatefabrik Gesellschaft M.B.H., Nuremberg, Germany
Telephonfabrik Berliner A.G. and Subsidiaries, Berlin, Germany
Nederlandsche Standard Electric Maatschappij N.V., Hague, Netherlands
Dial Telefonkereskedelmi Részvény Társaság, Budapest, Hungary
Standard Villamossági Részvény Társaság, Budapest, Hungary
Telefongyár R.T., Budapest, Hungary
Fabbrica Apparecchiature per Comunicazioni Elettriche, Milan, Italy
Standard Elettrica Italiana, Milan, Italy
Società Italiana Reti Telefoniche in Urbane, Milan, Italy
Nippon Electric Company, Limited, Tokyo, Japan
Sumitomo Electric Industries, Limited, Osaka, Japan
Standard Telefon- og Kabelfabrik A/S, Oslo, Norway
Standard Electrica, Lisbon, Portugal
Compañía Radio Aerea Marítima Española, Madrid, Spain
Standard Eléctrica, S.A., Madrid, Spain
Aktiebolaget Standard Radiofabrik, Stockholm, Sweden
Standard Telephon et Radio S.A., Zurich, Switzerland

Telephone Operating Systems

Compañía Telefónica Argentina, Buenos Aires, Argentina
Compañía Telefónica Comercial, Buenos Aires, Argentina
Compañía Telefónica del Plata, Buenos Aires, Argentina
Companhia Telefonica Paranaense S.A., Curitiba, Brazil
Companhia Telefonica Rio Grandense, Porto Alegre, Brazil
Compañía de Teléfonos de Chile, Santiago, Chile
Compañía Telefónica de Magallanes S.A., Punta Arenas, Chile
Cuban Telephone Company, Havana, Cuba
Cuban American Telephone and Telegraph Company, Havana, Cuba
Mexican Telephone and Telegraph Company, Mexico City, Mexico
Compañía Peruana de Teléfonos Limitada, Lima, Peru
Puerto Rico Telephone Company, San Juan, Puerto Rico
Shanghai Telephone Company, Federal, Inc., U.S.A., Shanghai, China

Radiotelephone and Radiotelegraph Operating Companies

Compañía Internacional de Radio, Buenos Aires, Argentina
Compañía Internacional de Radio Boliviana, La Paz, Bolivia
Companhia Radio Internacional do Brasil, Rio de Janeiro, Brazil
Compañía Internacional de Radio, S.A., Santiago, Chile
Radio Corporation of Cuba, Havana, Cuba
Radio Corporation of Porto Rico, Santurce, Puerto Rico¹

¹ Radiotelephone and Radio Broadcasting services.

Cable and Radiotelegraph Operating Companies

(Controlled by American Cable & Radio Corporation)

The Commercial Cable Company, New York, New York²
Mackay Radio and Telegraph Company, New York, New York³
All America Cables and Radio, Inc., New York, New York⁴
Sociedad Anónima Radio Argentina, Buenos Aires, Argentina⁵

² Cable service. ³ International and Marine Radiotelegraph services.

⁴ Cable and Radiotelegraph services. ⁵ Radiotelegraph service.

Laboratories

International Telecommunication Laboratories, Inc., New York, New York
Federal Telecommunication Laboratories, Inc., Nutley, New Jersey
Standard Telecommunication Laboratories Ltd., London, England
Laboratoire Central de Télécommunications, Paris, France